



3010 and 3011 (3010 Series) RF Synthesizer PXI Modules



User Manual

Document no. 46892/637

Issue 10

30 November 2010

About this manual

This manual explains how to set up and configure an Aeroflex 3010 or 3011 RF Synthesizer PXI module. Where necessary, it refers you to the appropriate installation documents that are supplied with the module.

Please note: this manual applies only when the instrument is used with the supplied software.

This manual provides information about how to configure the module as a stand-alone device. However, one of the advantages of Aeroflex 3000 Series PXI modules is their ability to form versatile test instruments, when used with other such modules and running 3000 Series application software.

Getting Started with afSigGen and *Getting Started with afDigitizer* (supplied on the CD-ROM that accompanies each module (see [Associated documentation](#))) explain how to set up and configure a 3010 Series RF synthesizer with a 3020 Series RF signal generator module or a 3030 Series RF digitizer module. Using the soft front panels and/or dll or COM object supplied, the modules form instruments that provide the functionality and performance of integrated, highly-specified signal generators or digitizers, but with the adaptability to satisfy a diverse range of test or measurement requirements.

© Aeroflex Ltd. 2010

No part of this document may be reproduced or transmitted in any form or by any means, electronic or mechanical, including photocopying, or recorded by any information storage or retrieval system, without permission in writing by Aeroflex Ltd. (hereafter referred to throughout the document as 'Aeroflex').

Intended audience

Engineers who need to synthesize signals in the range 1.5 GHz to 3.0 GHz.

This manual is intended for first-time users, to provide familiarity with basic operation. Programming is not covered in this document but is documented fully in the [help files](#) that accompany the drivers and associated software on the CD-ROM.

Driver version

To maintain optimum performance, 3000 Series PXI modules should be used either with the software driver version with which they were supplied, or the latest driver, which you can download from the Aeroflex website. Aeroflex endeavours to ensure modules remain backwards compatible with earlier driver version releases.

Associated documentation

If you want to...	Refer to...
Find information about soft front panels, drivers, application software, data sheets, getting started and user manuals for this and other modules in the 3000 Series.	PXI Modules CD-ROM Part no. 46886/028 Supplied with the module
Install modules into a rack, interconnect them, power up and install drivers.	3000 Series PXI Modules Common Installation Guide Part no. 46882/663 On the CD-ROM and at www.aeroflex.com/pxi
Set up a populated chassis ready for use.	3000 Series PXI Modules Installation Guide for Chassis Part no. 46882/667 On the CD-ROM and at www.aeroflex.com/pxi
Set up and use the universal PXI application for system configuration and operation.	PXI Studio User Guide Part no: 46892/809 On the CD-ROM and at www.aeroflex.com/pxi
Set up and use a digitizer application for 3010 Series and 3030 Series modules.	Getting Started with afDigitizer Part no. 46892/676 On the CD-ROM and at www.aeroflex.com/pxi

PREFACE

<p>Set up and use a signal generator application for 3010 Series and 3020 Series modules.</p>	<p>Getting Started with afSigGen</p> <p>Part no. 46892/678</p> <p>On the CD-ROM and at www.aeroflex.com/pxi</p>
<p>Download example source code</p>	<p>You can download examples of source code (written for different application development environments) from the Aeroflex website here.</p>

IQCreator[®] is a registered trademark of Aeroflex International Inc. in the US

PXI[™] is a registered trademark of the PXI Systems Alliance

Windows[™], Windows XP[™] and Windows NT[™] are trademarks of Microsoft Corporation

Preface

Patent protection

The 3010 Series RF Synthesizer PXI module is protected by the following patents:

GB 2294599

US 5781600
4609881

EP 0125790

The PXI concept

VXI and GPIB systems meet the specific needs of instrumentation users but are often too large and expensive for mainstream applications. PC-based instrumentation may cost less but cannot meet the environmental and operational requirements of many systems.

PXI (PCI Extensions for Instrumentation) is based on CompactPCI, itself based on the PCI standard. PCI was designed for desktop machines but CompactPCI was designed for industrial applications, and features a rugged Eurocard format with easy insertion and removal. PXI adds to the CompactPCI specification by defining system-level specifications for timing, synchronization, cooling, environmental testing, and software. While PXI extends CompactPCI, it also maintains complete interoperability so that you can use any CompactPCI-compliant product in a PXI system and vice versa. PXI also makes use of Windows software, VXI timing and triggering, and VXIplug&play instrument drivers to provide powerful and affordable systems.

PXI Express now integrates PCI Express into PXI, providing up to 6 Gbyte/s backplane bandwidth and up to 2 Gbyte/s slot bandwidth. PXI Express maintains backwards compatibility with PXI, providing software compatibility and hardware compatibility with hybrid slots and hybrid systems.

GENERAL INFORMATION

Introduction

This is the user manual for the 3010 and 3011 ('3010 Series') RF Synthesizer PXI modules. These high-performance frequency synthesizers:

- cover the frequency range 1.5 GHz to 3.0 GHz with 1 Hz resolution.
- use a single-width 3U module to provide the noise performance and frequency agility of conventional rack instruments.
- can be used as stand-alone frequency synthesizers, or as core synthesizers providing a local oscillator for the 3020 Series digital RF signal generator or the 3030 Series RF digitizer.
- The 3011 additionally provides a stable common 10 MHz reference to the 3020 and 3030 Series.

Applications

Used with the 3020 Series, the 3010/3011 form an IQ modulated signal source with a potential maximum frequency range of 86 MHz up to 6 GHz and output level range of +5 dBm to -120 dBm.

Used with the 3030 Series, the 3010/3011 form an RF digitizer for input signals in a potential maximum frequency range of 330 MHz to 6 GHz, and up to 33 MHz in bandwidth.

High stability frequency reference

The 3010 is supplied for use with either an internal VCXO frequency standard or an external 10 MHz frequency reference.

The 3011 is a high stability variant, fitted with an OCXO.

Software

The 3010/3011 are supplied with a VXI PNP driver and soft front panel, and a dll, a COM object, and a .net assembly that provide similar functionality to the driver.

PXI Studio, also supplied with the module, configures your PXI modules as logical instruments using an intuitive and powerful graphical interface. *PXI Studio* provides comprehensive signal generator, digitizer and spectrum analyzer applications and optional analysis plugins to suit specific communication systems.

RF Investigator, also supplied with the module, is an application that provides combined operation of all Aeroflex 3000 Series modules from a single user interface, especially useful for acceptance testing.

Deliverable items

- 3010 or 3011 RF Synthesizer PXI module
- PXI Modules CD-ROM part no. 46886/028, containing soft front panels, drivers, application software, data sheets, installation guides, safety instructions, getting started and user manuals for this and other modules in the 3000 Series.
- *3000 Series PXI Modules Safety Instructions*: printed item, part no. 46882/882
- SMA connector cable: part no. 43139/738, 2 off
- SMA connector saver: part no. 46885/224, 1 off

Cleaning

Before commencing any cleaning, switch off the chassis and disconnect it from the supply. You can wipe the front panel of the module using a soft cloth moistened in water, taking care not to wet the connectors. Do not use aerosol or liquid solvent cleaners.

Putting into storage

If you put the module into storage, ensure that the following conditions are not exceeded:

Temperature range: -20 to $+70^{\circ}\text{C}$ (-4 to $+158^{\circ}\text{F}$)
Humidity: 5 to 93%, non-condensing

Specifications

For the latest specifications, see the data sheet included on the CD-ROM (part no. 46886/028) or go to the Aeroflex [website](#).

All 3010 Series specifications are defined when used in conjunction with the driver software supplied with the module.

Warm-up time

Allow five minutes for a 3011 module to warm up and meet its specifications fully. A 3010 performs to specification immediately.

Calibration and servicing

The recommended calibration interval is 24 months.

There are no user-serviceable parts in these modules; if any attention is needed, return the module to your Aeroflex agent.

INSTALLATION

WARNING

Initial visual inspection

Refer to the *3000 Series Common Installation Guide* part no. 46892/663 on the PXI Modules CD-ROM, part no. 46886/028.

CAUTION

Handling precautions

Refer to the *3000 Series Common Installation Guide* part no. 46892/663 on the PXI Modules CD-ROM, part no. 46886/028.

Hardware installation

WARNING

Before installing the module into the chassis, check inside the chassis:

- (a) that no foreign conductive bodies are present between pins on the backplane connectors
- (b) that no pins on the backplane connectors are bent or damaged.

Installing the module into the PXI chassis

Refer to the *3000 Series Common Installation Guide* part no. 46892/663 and *Installation Guide for Chassis* part no. 46882/697 on the PXI Modules CD-ROM, part no. 46886/028.

Connector care and maintenance

How to connect and torque an SMA connector

- 1 First, ensure that the mating halves of the connector are correctly aligned.
- 2 Next, engage the threads of the nut and tighten it by hand, ensuring that the mating halves do not move relative to each other.
- 3 Then use a torque wrench to tighten the connector, in order to ensure consistent matching and to avoid mechanical stress.

Torque settings for connectors are:

0.56 Nm test torque (development use, semi-permanent installations)

1 Nm final torque (permanent installations)

Never use pliers to tighten connectors.

CAUTION

Overtightening will cause damage!

Do not allow center pins to rotate!

Do not allow the center pins of connectors to rotate when you connect and remove cables.

Use a connector saver!

Use a connector saver (part no. 46885/224, supplied):

- (a) on any connector where the cable is routinely connected and disconnected
- (b) when the connector on the cable, or the cable end of the connector saver, has not been gauged.

Torque to 1 Nm the end of the connector saver that connects to the module, and torque to 0.56 Nm the end that connects to the cable.

Regular maintenance

SMA

Clean connectors regularly, using a cotton bud dipped in isopropyl alcohol. Wipe within the connector cavity, then use a dry cotton bud to finish off. Check for any deposits.

Do not use other cleaners, as they can cause damage to the plastic insulators within the connectors.

Cap unused connectors.

PCI

Protect PCI connector pins by keeping modules in their original packing when not fitted in the rack.

OPERATION

Front-panel connectors

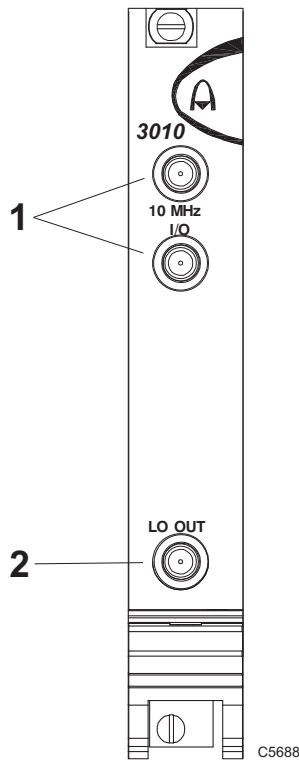

1 10 MHz I/O Two SMA I/O sockets in parallel.

See [10 MHz I/O sockets](#).

Input (3010 and 3011)
Frequency standard input.

Output (3011 only)
Frequency standard output.

2 LO OUT 1.5 to 3 GHz RF output (fixed level,
in range -4 to $+3$ dBm). SMA
socket, 50Ω .

Fig. 1 3010 front panel (3011 is similar)

10 MHz I/O sockets

These are two I/O sockets, wired in parallel, which can be used to ‘loop through’ signals. Both the 3010 and 3011 can accept an external frequency standard input at these sockets. The 3011 can also output a 10 MHz reference from its OCXO on these sockets. The 3010 does not output a 10 MHz signal.

The sockets can be used to link signals between modules and other equipment, in which case their impedance can be set high. If the module is terminating a signal, the sockets’ impedance can be set low.

Input (3010 and 3011)

Frequency standard input. SMA socket, high or low (50 Ω) impedance. 0.4 to 4 V pk-pk sine or TTL.

Locking range 10 MHz \pm 100 Hz.

Set the module to External reference mode to input a frequency standard.

Output (3011 only)

10 MHz frequency standard output from OCXO. 2 V pk-pk nominal square wave. SMA socket, TTL into 50 Ω .

Soft front panel (af3010_sfp)

The soft front panel provides a graphical interface for operating the module. It is intended for testing and diagnosing, for demonstration and training, and for basic operation of the module. It represents most of the functions available in the instrument driver. It is not however a comprehensive application suitable for measurements; for this, use the afDigitizer dll, the afcomDigitizer COM object, the .net assembly (afDigitizerDotNet.dll) or PXI Studio.

Installation

The soft front panel is installed during the driver installation process (refer to the *3000 Series PXI Modules Common Installation Guide*, part no. 46882/663, on the PXI Modules CD-ROM).

Access the soft front panel from the Windows Start menu under *Programs\Aeroflex\PXI Module Front Panels\AF3010 Soft Front Panel*. Or open the *af3010_sfp.exe* file, which if you did not change the default location, is located with the VISA software. The soft front panel, similar to that in Fig. 2, is displayed.

Detailed help information

Soft front panel controls are all available as [driver export functions](#) unless noted otherwise, and are documented in the [help files](#). This user manual provides an overview of the facilities that the module provides and summarizes its operation; however, refer to the help files for detailed descriptions of functions together with their parameter lists and return values.

SOFT FRONT PANEL OPERATION

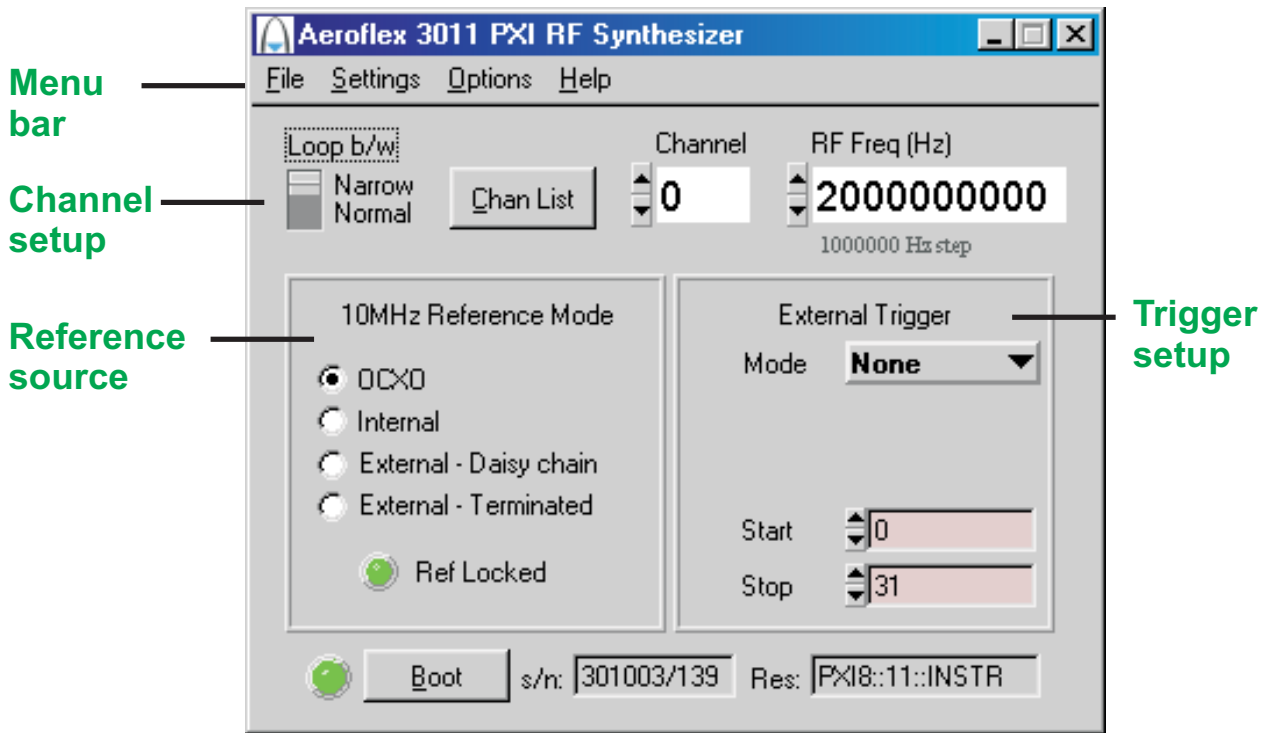

C6353

Fig. 2 Synthesizer soft front panel (3010 is similar)

Menu bar

File

Click **F**ile**E**xit on the [menu bar](#) to close the application.

Settings

Settings**L**oad and **S**ettings**S**ave on the [menu bar](#) allow you to load and save soft front panel configuration from and to your preferred locations. If you did not change the default location, it is the same as for the VISA software (refer to the *3000 Series PXI Modules Common Installation Guide* for details), and configurations are saved as *.ini* files.

You can edit, copy and paste settings files as required; for example, you may want to save only a new RF frequency without changing other parameters. Edit the saved *.ini* file using a text editor (for example, Notepad) to remove unwanted parameters. Ensure only that you do not delete the General (VendorID, DeviceID) and Version (Major/Minor) parameters. Save the changed file. When the settings file is next loaded, the configuration of the soft front panel changes to match the parameters remaining in the settings file.

Settings**D**irectories on the [menu bar](#) lets you choose the default directory for your front-panel configuration settings.

Options

Allows you to enable or disable additional instrument options if you have the appropriate password (available from the [Aeroflex sales desk](#)). Click **Options\Edit...** on the [menu bar](#) to display the options screen.

Disabled options are shown grayed out. To enable an option, enter the appropriate password. Click **Enable**. The enabled option is shown highlighted in green. Click **OK**.

Help

Instrument Information provides the module's PXI resource code and serial number, revision numbers for driver, FPGA and PCI, and its last calibration date.

About provides the version and date of the soft front panel.

Boot

Click **Boot** ([here](#)) to initialize the module and view the Boot Resource window. Resources available for initializing are shown in blue.

Select the 3010 or 3011 you want to boot. Note that the Boot Resource window makes no distinction between 3011 (synthesizer module with OCXO) and 3010 (synthesizer module), showing both as '3010'.

Check the box to use the boot default configuration. Do not change the configuration unless you are advised otherwise.

Click **OK**. While you select the boot resource, the indicator is amber. Once the module has initialized, the indicator changes to green in a few seconds.

If no calibration data is available, the driver returns a caution. If this happens, return the module for calibration.

s/n:

After the module initializes, this field displays its serial number.

Res:

After the module initializes, this field displays its VISA resource string.

Channel setup

Loop b/w

Click to toggle between Narrow and Normal. Select Narrow loop bandwidth for better phase noise, or Normal for fastest switching speed consistent with good signal quality.

Chan List

The Chan List box allows you to select the current channel in non-trigger mode by entering a channel number or by using the up/down arrows.

Click on **Chan List** to view the channel frequency list (Fig. 3). You can set up to 128 channels for hopping, by using the up/down arrows or entering digits.

CHANNEL SETUP ON SOFT FRONT PANEL

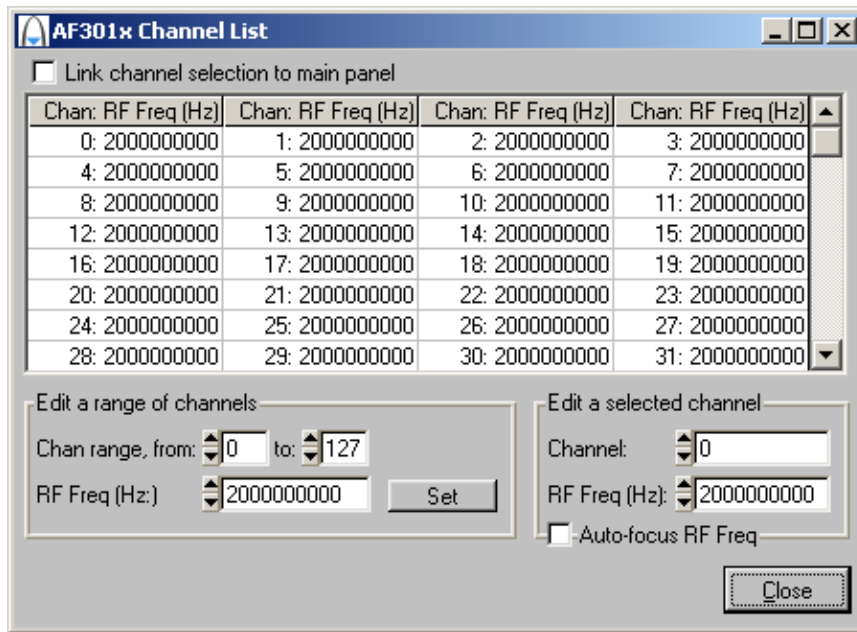

Fig. 3 Edit channel settings

The **Edit a range of channels** group lets you apply changes to a set of channels simultaneously, speeding up channel setup.

- Define start and finish values for address numbers in the **Chan range, from:** and **to:** fields.
- Insert values and click **Set** for each field. You are asked to confirm each action. When finished, click **Close** to return to the Channel List screen.

Alternatively, **Edit a selected channel** to change individual entries.

If you check the **Link channel selection to main panel** box, clicking on any channel on this screen makes it become the active channel on the soft front panel.

Check the **Auto-focus RF Freq** box to make the associated RF Freq field active when you click on a channel in the grid.

RF Freq (Hz)

Set the synthesizer frequency for the current channel using the up/down arrows or by entering the frequency in full or scientific (e) notation. If this module is being used with a 3020 Series Signal Generator or 3030 Series Digitizer module, set this value to the required LO frequency.

Step size: double-click on the step value under the frequency field to set up the size of frequency step.

Reference source

10MHz Reference Mode

OCXO

Uses the internal 10 MHz OCXO (3011 only). In this mode, the high-stability reference signal is output to the 10 MHz I/O sockets.

Note: if a 3011 is booted using a 3010, SigGen or Digitizer soft front panel, it defaults to this 'OCXO enabled' state. If the application is closed, the OXCO remains on.

Internal

Uses the internal 10 MHz VCXO (3010 only). There is no output to the 10 MHz I/O sockets.

External – Daisy chain

Sets the 10 MHz I/O sockets to high impedance and applies an externally sourced 10 MHz signal to them. There is no output to the 10 MHz I/O sockets.

External – Terminated

Sets the 10 MHz I/O sockets to 50 Ω and applies an externally sourced 10 MHz signal to them. There is no output to the 10 MHz I/O sockets. Use this mode if this module is the termination for the 10 MHz standard.

Note: to avoid interference when a 3010 or 3011 is set to Internal/OCXO, remove any external reference from the 10 MHz I/O connector.

Ref Locked

This indicator is lit when the 3010 Series module is locked to an external 10 MHz reference signal. If it is not lit, the external reference is missing.

Trigger setup

External Trigger

Used to control channel-hopping.

Mode

- None** Not in hopping mode
- Advance** Step incrementally through the list of 128 channels. The Start and Stop fields let you set a subset of channels.
- Toggle** Toggles between Channel 0 and Channel 1.
- Hop** Receives the channel address from the PXI backplane. Provides completely independent hopping.

Source

Defines which lines on the PXI backplane are used for external triggering or addressing. Select from:

- PTB** PXI Trigger Bus 0 to 7
- LBR** Local Bus Right 0 to 12
- LBL** Local Bus Left 0
- STAR** Star trigger

Program files

Program files are installed onto your computer from the CD-ROM.

Find registered com DLLs and ocx components, *.net* assemblies, libraries, source and associated help files in the program installation folder on your computer. This is typically:

C:\Program Files\Aeroflex\PXI

All executable C DLLs are installed in:

C:\WINDOWS\system32

Driver export functions

On-line help and functional documentation for driver export functions are available on the CD-ROM supplied with your module. They are installed onto your computer at the same time as the drivers.

Driver installation folder

Find help and functional documentation in the driver installation folder on your computer. If you did not change the default location, this is typically the same as for the VISA software.

Help

Within the driver installation folder are help files that provide descriptions, parameter lists and return values. Help files are provided in three formats:

<i>af3010.doc</i>	3010 function documentation	Text file
<i>af3010.hlp</i>	3010 Visual BASIC function reference	} Windows Help file format
<i>af3010_C.hlp</i>	3010 C language function reference	

We recommend that you use the C or Visual Basic formats as these are easier to navigate.

A help file opens at the Contents page:

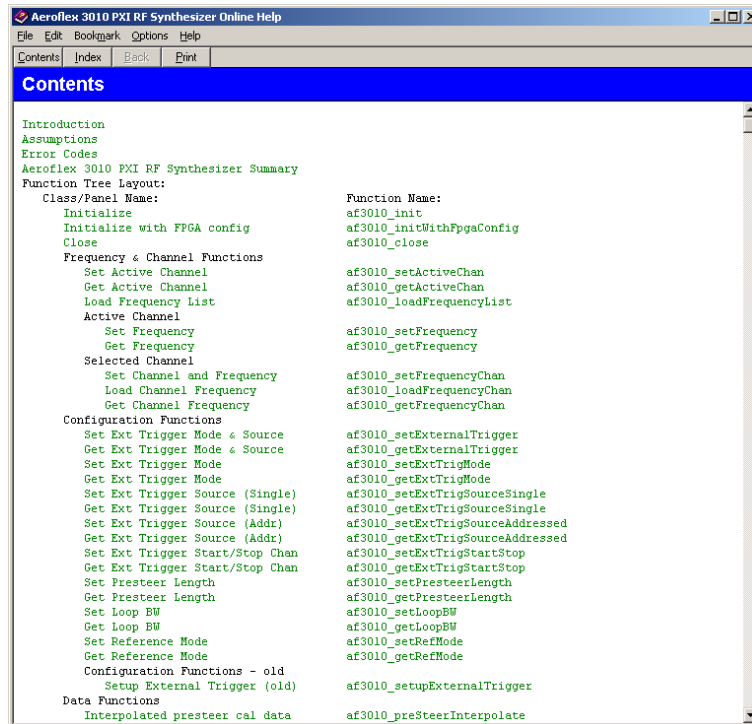

Fig. 4 Online help contents — example

Hyperlinks from here take you to

[Introduction](#)

[Assumptions](#)

[Error codes](#)

[Functions listings.](#)

Function listings

Functions are grouped by type. Click on the hyperlink for details of the function. Each function has a description of its purpose, and may have a list of parameters and return values.

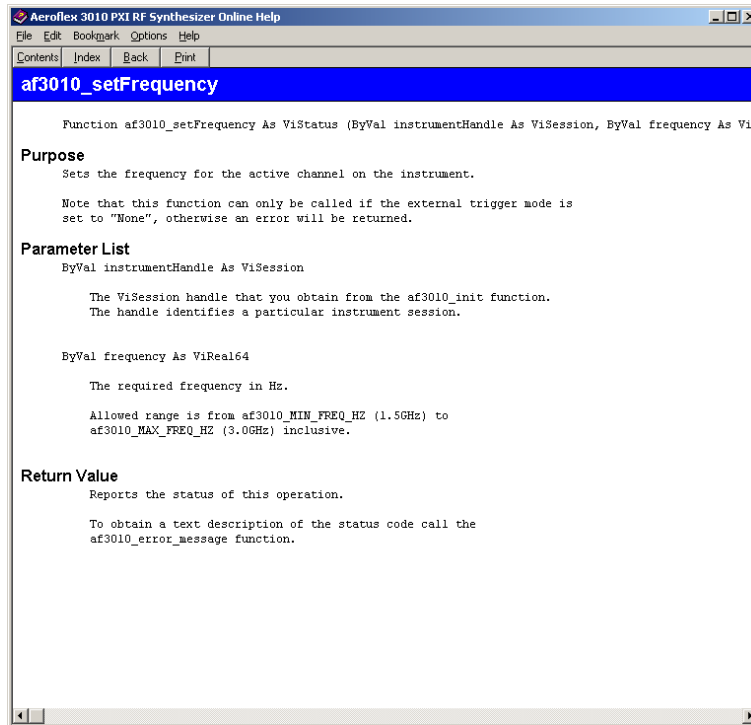

Fig. 5 Function listing — example

BRIEF TECHNICAL DESCRIPTION

Introduction

A 3010 Series module is a PXI RF synthesizer covering the frequency range 1500 to 3000 MHz, with a fixed nominal output level of 0 dBm. Its primary purpose is to act as an excitation unit for an RF signal generator (Aeroflex 3020 Series), and as a local oscillator for an RF digitizer (Aeroflex 3030 Series).

The 3010 contains a single circuit board containing a PCI interface, power supply conditioning, and the fractional-N based synthesizer circuitry. Connections at the rear of the module are the two PXI connectors (J1 and J2), comprising 32-bit PCI, PXI bus extensions, and power supply. Connections at the front of the module are two 10 MHz reference input/outputs (SMA), and the RF output (SMA). A [block schematic](#) for the instrument is shown in Fig. 6.

The 3011 is identical to the 3010, with the exception that the 3011 has a high-stability OCXO.

BRIEF TECHNICAL DESCRIPTION

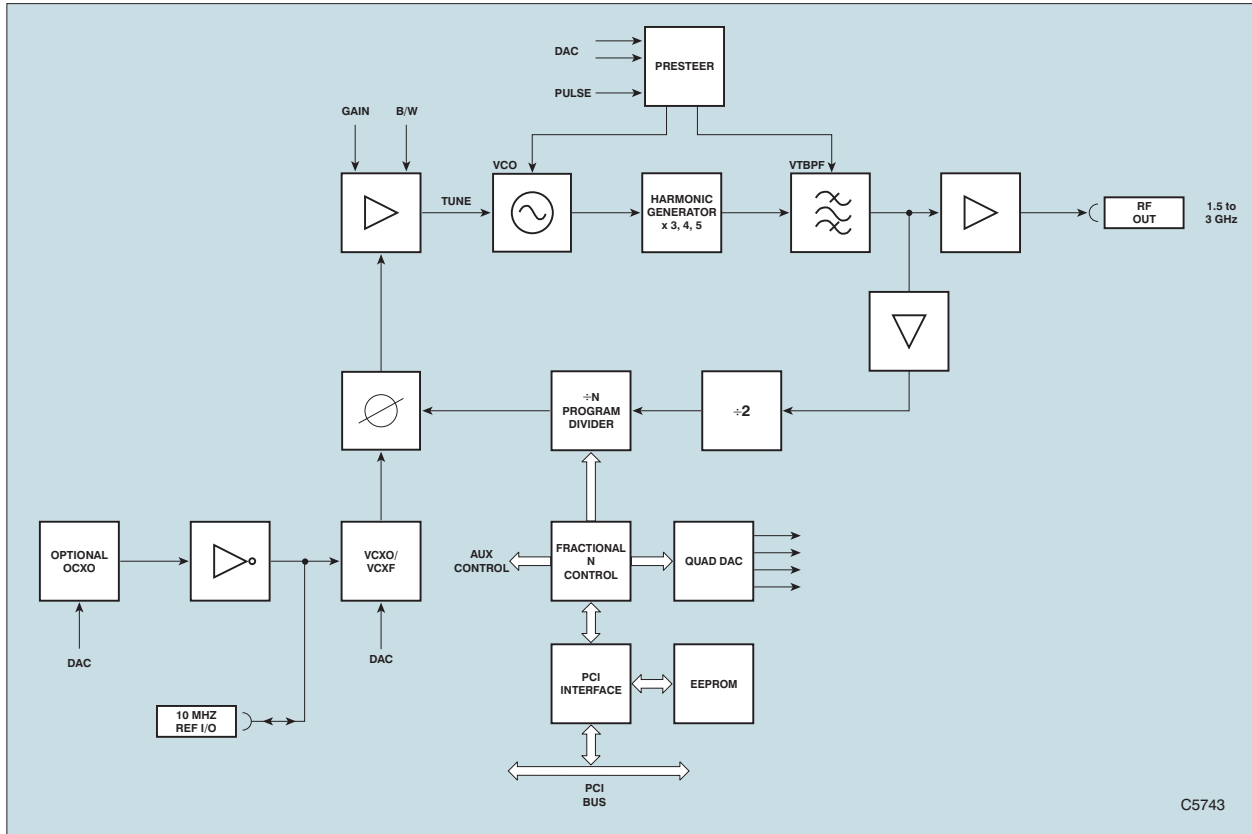

C5743

Fig. 6 Block schematic diagram

GLOSSARY

ADC	An Analog-to-Digital Converter converts a time-varying signal to discrete binary values.
AM	Amplitude Modulation: modulation of the amplitude of a carrier wave.
ARB	Arbitrary Waveform Generator: allows you to edit, generate and play complex recurring waveforms.
COM	Component Object Model: a way of implementing objects that can be used in environments different from the one they were created in, even across machine boundaries, and independently of language. COM allows the reuse of objects with no knowledge of their internal implementation, as well-defined interfaces are all that is visible to the user.
CW	Continuous Wave: electromagnetic waves, the successive oscillations of which are identical under steady-state conditions, which can be interrupted or modulated to convey information.
DAC	Digital-to-Analog Converter: device that converts a digital code to a time-varying analog signal.
dB	Decibel: a dimensionless logarithmic unit of measurement that expresses the ratio of a power relative to a specified or implied reference level.
dBc	Decibel value specified relative to the carrier level.
dBm	Decibels value specified relative to 1 mW.
dll	dynamic link library: an executable file that allows programs to share code and other resources necessary to perform particular tasks.
GND	Ground
GPIO	General Purpose Interface Bus: a parallel interface defined by the IEEE 488 standard, used for attaching sensors and programmable instruments to a computer.
HF	High Frequency: radio signals in the range 3 MHz to 30 MHz.
IF	Intermediate Frequency: a frequency to which a carrier frequency is shifted as an intermediate step in superheterodyne transmission or reception.

GLOSSARY

IQ	In-phase/Quadrature modulation. A modulation scheme where a signal is modulated by two signals 90 degrees out of phase with each other.
LED	Light-Emitting Diode
LO	Local Oscillator: an electronic device used to generate a signal normally used to convert a signal of interest to a different frequency using a mixer. See IF.
LVDS	Low-Voltage Differential Signaling: uses a current source to transmit and receive fast signals over simple twisted-pair cable.
MF	Medium Frequency: radio signals in the range 300 kHz to 3 MHz.
PCI	Peripheral Component Interconnect
PNP	Plug-'N'-Play
PXI	PCI eXtensions for Instrumentation
PXI Express	Backwards-compatible with PXI, but providing faster timing and signal lines.
RF	Radio Frequency
RMS	Root Mean Square: the most common mathematical method of defining the effective voltage or current of an AC waveform.
SFP	Soft Front Panel: a representation of an instrument's control panel, generated in software, which allows you to control the underlying software and hardware.
SMA	SubMiniature version A (connector)
SMB	SubMiniature version B (connector)
TTL	Transistor-Transistor Logic: switching voltage ranges are $V_{OL} = 0.4 \text{ V}$, $V_{OH} = 2.4 \text{ V}$, $V_{IL} = 0.8 \text{ V}$, $V_{IH} = 2.0 \text{ V}$
UHF	Ultra High Frequency: radio signals in the range 300 MHz to 3 GHz.

GLOSSARY

VCO	Voltage-Controlled Oscillator: a frequency generator whose output frequency is a function of an applied voltage. If the applied voltage varies, the output is modulated.
VHF	Very High Frequency: radio signals in the range 30 MHz to 300 MHz.
VXI	VMEbus Extension for Instrumentation