

# Application Note

**AEROFLEX**  
A passion for performance.

## An Introduction to Digital and Vector Modulation



The transmission of data or digitally encoded speech has resulted in the adoption of a variety of methods to transmit the information. This Technical Information explains basic techniques used and the difficulties that a communication system can encounter in a practical system.

### Introduction

Many new schemes for conveying speech or data information on an RF carrier for land line or radio transmission have been developed using different forms of modulation other than the older analog schemes for speech. The

modulation formats are still based on either amplitude (AM) or angle modulation (FM or  $\dot{A}EM$ ) or a combination of both. However the detail of how they are most easily generated and demodulated is very different.

For the very latest specifications visit [www.aeroflex.com](http://www.aeroflex.com)

## Digital Modulation

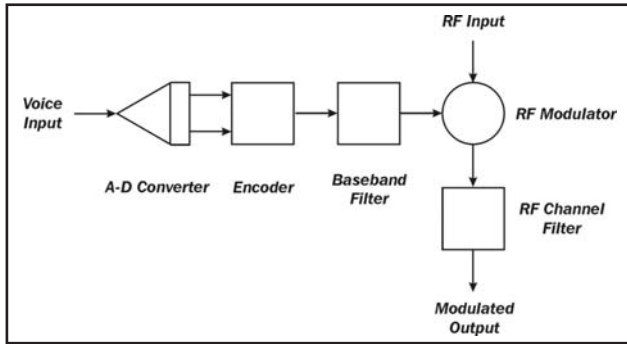

Figure 1 - Simplified Digital Modulator

Digital modulation can take many different forms. The basic method of modulation is the same as a conventional analog system but the method of inserting the modulation on the carrier is different. In an analog modulation system the signal is first filtered by an analog low pass or bandpass filter and then is applied directly to the modulator to produce either AM or angle modulation, or a combination of both.

In digital modulation systems the information to be transmitted is first converted to a digital format. The simplest digital modulation schemes have two possible states so only one bit of data can be sent at a time. The oldest form of radio communication, Morse Code keying, is an example of a two level system. Multi-level systems have four or more allowed states and so can send two or more bits of data at a time. Where this is the case the data rate can either be expressed as the data rate in bits per second or as a symbol rate in symbols per second. Where two bits are sent at a time (4 allowed states), for instance, the symbol rate will be half the bit rate.

The digital information is then converted into a defined structure by an encoder whose output is filtered by a base band filter before being used to modulate the carrier. Clearly the major difference between analog and digital modulation is the digital conversion process and not the modulation process, though some digital modulation schemes use formats which are not used for analog transmission.

### Vector Modulation

Classical modulation schemes use either amplitude or angle modulation. The modulators used can either generate angle modulation (frequency or phase) or amplitude modulation. The modulator does not allow both the angle and amplitude of the carrier to be altered.

Vector modulation schemes allow a single modulator to control both amplitude and phase. The resulting modulation is usually drawn as an IQ diagram - hence the other common term, IQ modulation, used for this format.

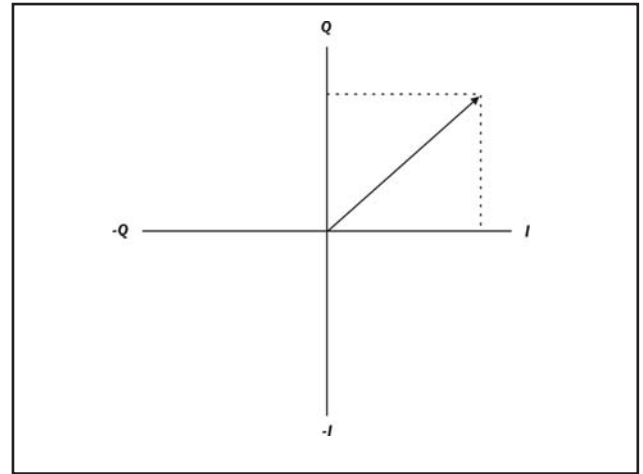

Figure 2 - I Q Diagram

The modulation is shown by plotting the amplitude and the phase of the modulated carrier compared to the unmodulated carrier. The plot shows the amplitude as a vector line whose length is proportional to the amplitude of the carrier at a given instance and the relative phase is shown as the angle between the horizontal axis and the vector. The resulting plot is called an IQ diagram.

An IQ diagram has two axes. It make use of the fact that a carrier with an arbitrary phase and amplitude can be described as being constructed from an in-phase signal (I) and a signal which is in phase quadrature with it (Q). By adding together these two signals and allowing negative amplitudes (i.e. signals 180° out of phase) any signal can be defined.

One common method of generating vector signals makes use of this attribute - the IQ modulator.

### FM and AM on an IQ diagram

Amplitude modulation can be represented as a vector whose length is modulated by the modulation waveform. It can be visualised as a fixed vector with an additional vector of the same phase whose amplitude varies in a positive or negative direction in sympathy with the modulation source.

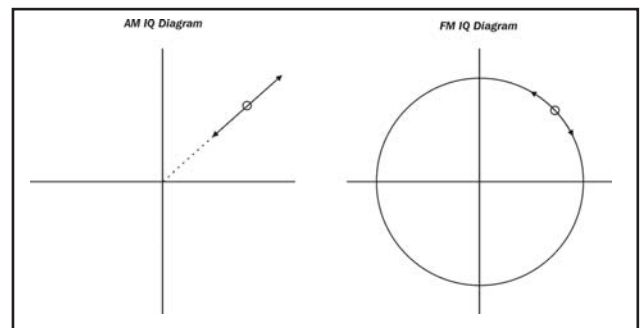

Figure 3 - AM and FM IQ Diagram

Ideally the phase of an amplitude modulated signal does not vary. Real amplitude modulators are likely to introduce some phase modulation as the amplitude is varied.

Frequency modulation does not change the amplitude of the signal - it only changes its relative phase. A DC signal applied to an FM modulator will cause a frequency shift which is equivalent to a

constant increase in phase. The IQ vector will therefore constantly rotate clockwise or anti-clockwise depending on whether the frequency shift is up or down. Generating FM signals with an IQ Modulator is not generally straight forward.

### **IQ Modulators**

An IQ modulator uses a 90° phase shifter, two mixers and an RF summing junction to generate the required arbitrary phase and amplitude of RF signal. The two mixers are operated as amplitude control elements by using the local oscillator and RF ports as the inputs and output and the IF port as a control signal. With 0 volts on the IF port the mixer ideally generates no RF output. Applying a positive or negative signal to the IF port of the mixer results in a signal being generated in proportion to the applied signal level. A negative input signal produces an RF output which is 180° out of phase compared to the positive input signal.

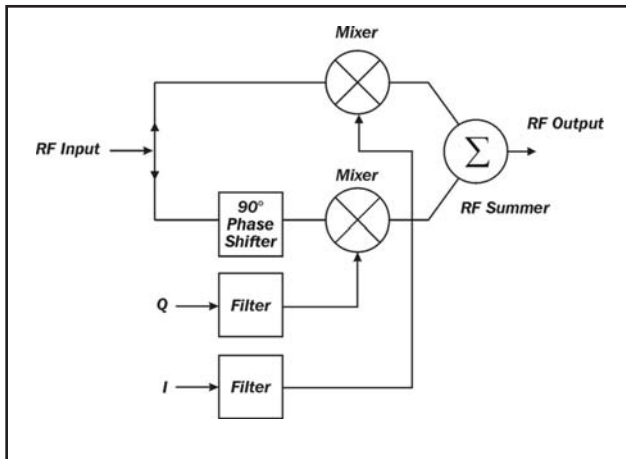

Figure 4 - IQ Modulator

To provide an I and Q component the carrier applied to one mixer is phase shifted by 90° compared to the other mixer. By simply adding these signals together and providing the appropriate control signals any phase and amplitude of carrier can be generated.

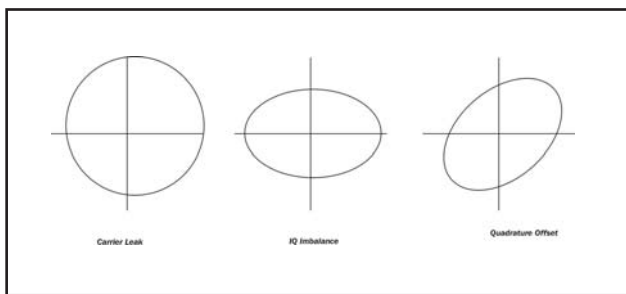

Figure 5 - Effect of IQ Modulator Errors

Practical IQ modulators suffer from a number of problems. The mixers are not perfectly balanced so in practice with 0 volts applied to the I and Q inputs some residual carrier signal is present. This error source is referred to as Carrier Leak and dominates when the signal to be generated is close to the IQ origin (ie the signal level is very low). The two channels may not be exactly 90° apart and this will produce I and Q skew. The relative amplitudes of the two RF paths and the I and Q drives may not be exactly the same. This will result in IQ imbalance errors.

The importance of each source of error is likely to be dependent upon the type of modulation being generated.

### **Why use Digital Modulation?**

The most common reasons stated for using digital modulation for transmitting an analog signal (e.g. speech) is to provide better spectrum efficiency and better transmission quality.

Better spectrum efficiency than analog systems is provided not because of the method of modulation - it is because of the fact that the information is converted to a digital format and this provides other opportunities for improving reception and reducing data rates.

In the case of speech a digitally coded signal carrying all the analog speech information would occupy a wider frequency spectrum than an analog signal. However a device called a speech coder can be used to substantially reduce the amount of information to be transmitted. Speech coders make use of the fact that human speech is generated by the vocal tract and therefore an encoder only has to deal with a limited range of audio sounds. By making a model of what speech consists of the amount of information can be substantially reduced and this reduces the bandwidth requirement. Current technology can allow a digital system to typically occupy one third of the bandwidth of an analog transmission.

A compromise that has to be accepted is that the quality of the speech is not as good as that which can be obtained under good conditions with an analog transmission. Also if other information, such as music or traffic noise, is transmitted through the coder the resulting signal will be very distorted because the signal does not conform to the human speech model used by the coder. In fact coders may not cope well with the traditional 1 kHz test tones used for measuring SINAD on analog transmissions.

The use of a coder could cause another potential problem. Transmission errors caused by poor propagation conditions could cause the coder model to break down and result in a serious degradation of speech quality. Consequently digital systems include error correcting algorithms which effectively transmit more data than is strictly needed to convey a message. In the event of a transmission error occurring the redundancy can be used to detect and recover the error and so provide effectively error free transmission.

The correction of data bits also allows a digital radio to operate more satisfactorily in the presence of interfering signals from other transmitters. Consequently digital radios generally do not have to exhibit as good an adjacent channel rejection as their analog counterparts and closer frequency re-use of the spectrum can be accepted.

Under ideal conditions analog transmission quality is better than digital quality. However as the propagation conditions deteriorate (eg the S/N ratio gets worse) the digital transmission quality remains constant while the analog signal gracefully degrades. When the digital system finally receives too many errors to cope the digital transmission quality rapidly deteriorates.

## Channel Filters

Most transmission systems use filters to limit the modulation bandwidth and reduce interference from other sources. The band limiting filters can be applied either on the baseband modulation signal or on the RF modulated signal as a channel filter. In analog systems the filter will result in the transmitted speech being subjected to frequency and phase response errors. Within reason this usually makes very little impact on the intelligibility of the signal.

The filters introduce more serious problems in digital transmission systems. Ideally the filters should limit the bandwidth of the modulating signal without affecting the ability to demodulate it.

As the filter bandwidth is reduced the digital information becomes steadily more difficult to demodulate. This can be understood by considering what happens to a random string of digital signals as it is passed through a low pass filter. If the response time of the filter is slower than the time interval between the digital transitions then the digital signals effectively interfere with each other - you have to know what the signals were for the time intervals before the current signal in order to be able to predict the filtered signal level. This mutual interference is referred to as Intersymbol Interference (ISI).

When a modulation scheme is defined to use an IQ modulator (eg NADC or PDC) then a baseband filter used to filter the I and Q input signals can be shown to have the same effect as a channel filter and consequently the channel filters for these systems are usually implemented digitally in the I and Q drives.

For most systems one of two types of filter are generally used. Gaussian filters provide a gentle frequency response curve which results in no significant signal overshoot occurring when a pulse is applied to the filter. This is clearly desirable since it minimizes the peak level of the modulating signal. Gaussian filter bandwidths are usually quoted in terms of their 3 dB frequency response point (in Hz).

Gaussian channel filters can be implemented by cascading band-pass filters which are tuned to the same centre frequency and have no mutual coupling between the tuning elements. The equivalent channel filter bandwidth, measured between the upper and lower 3 dB points, will be twice the bandwidth of the low pass filter in the I Q drive.

The second type of filter is the Nyquist or Raised Cosine filter. This is a special type of filter which is very difficult to implement other than by using a digital method of generation. Nyquist filters have the special characteristic that if a narrow pulse (or impulse) is applied to the filter then the resulting output signal lasts for significantly more than one data period but if the output is measured at regular intervals after the impulse has been applied then the output is zero. This is a very useful characteristic since if the data rate is arranged so that it corresponds to this zero value interval then there can be no intersymbol interference. Consequently this type of filter is very popular for digital transmissions.

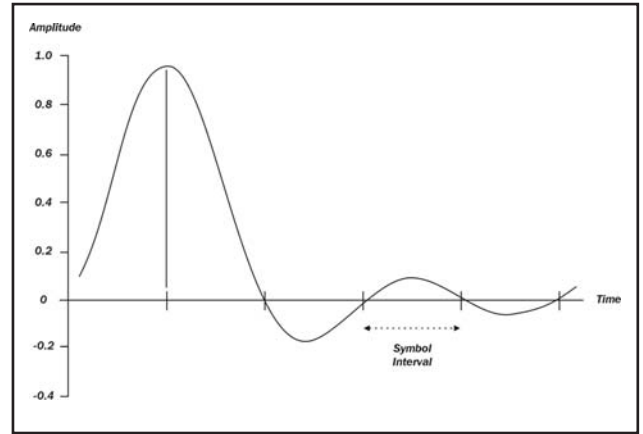

Figure 6a - Raised Cosine Filter (Impulse Response)

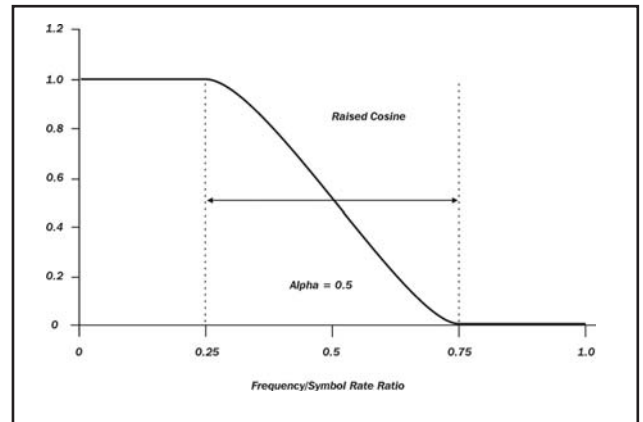

Figure 6b - Raised Cosine Frequency Response

A Nyquist filter uses a rather different definition of its filter bandwidth than that used for Gaussian filters. A Nyquist filter frequency response is flat up until a particular frequency and then exhibits low pass filter response which is the same as cosine. The 6 dB frequency response is always half the symbol rate of the data. The bandwidth is described as the filter alpha. The alpha is the proportion of the frequency occupied by the raised cosine part of the response referenced to the symbol rate. For an alpha of 1 (the maximum possible value) the raised cosine section starts at DC and its response reaches 0 at the symbol rate. For an alpha of 0 the response is flat to half the symbol rate and 0 above it (a classic "brick wall" filter). An alpha of 0.5 the response is flat to 0.25 of the symbol rate where the raised cosine portion starts, is 6 dB down at 0.5 of the symbol rate and falls to 0 at 0.75 of the symbol rate.

It should be noted that in order to obtain zero ISI the signal has to be sampled at exactly the right time - any departure from the correct time will result in some interference being generated. Also the presence of multiple propagation paths can cause problems since a time shifted version of the signal will be present.

In practice most transmission systems of this type use two filters - one in the transmitter and one in the receiver - to obtain optimum system performance. Each filter is then a Root Nyquist (or Root Raised Cosine) whose response is the square root of the overall required response. Multiplying a square root response by itself (the effect of having two filters in the transmission path) gives an overall Nyquist filter.

## Baseband Filters

Baseband filtering is carried out in the FM or phase modulation input to the RF source and is typically Gaussian or (Root) Raised Cosine. The effect is slightly different to a bandpass channel filter (or low pass filter at the input to an IQ modulator). In general the modulation harmonics created in the frequency domain by the Bessel functions results in the signals occupying a greater RF spectrum than the equivalent signal filtered by a similar channel filter. The difference is not large at the decision points and consequently many radio systems will in practice operate satisfactorily with either type of filter.

If Gaussian baseband filters are used the filter bandwidth is usually stated in terms of the Bt product. The Bt product is defined as the low pass filter 3 dB frequency multiplied by the time period between each data bit.

For DECT (Digital European Cordless Telephone) the Bt is defined as 0.5 and the data rate is 1152 kb/s. The 3 dB bandwidth of the Gaussian filter is therefore 576 kHz.

## Types of Modulation

FSK is one of the oldest forms of digital modulation. In FSK systems the digital signal is filtered (if necessary) and is then used to frequency modulate the carrier. The RF amplitude is constant. Most FSK systems use Gaussian filters to restrict the bandwidth since the filter minimizes deviation overshoots. The modulator should ideally be DC coupled, though for many applications the coding algorithm effectively prevents the generation of long strings of 1's and 0's which would make DC coupling essential. In addition the group delay and frequency response of the modulator needs to be adequately low so that the Gaussian filter response is not unduly distorted. Examples of FSK systems include POCSAG and ERMES pagers, DECT and CT2 portable phones.

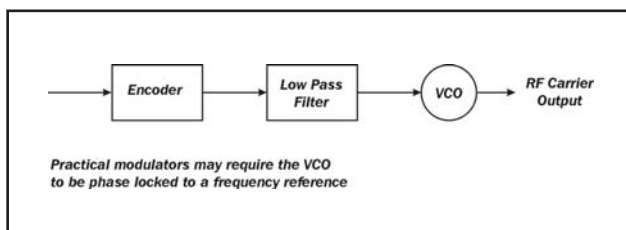

Figure 7 - FSK (Frequency Shift Keying)

Some systems use multi-level FSK signals. In these systems 2 (or more) bits per symbol are coded to give 4 (or more) levels of frequency shift. The ERMES paging system is an example of a 4 level FSK system. FSK systems are spectrally reasonably efficient and usually provide relatively low levels of signal in adjacent channels. Demodulation is relatively straightforward and the constant envelope allows for the use of efficient power amplifiers since amplitude linearity is not a serious problem.

## MSK

MSK is a form of FSK where the peak to peak FM deviation is set to be half the data rate. On an IQ diagram MSK signals result in the signal phase rotating 90° positive or negative between each bit of data. MSK is spectrally efficient even

without the use of a filter to restrict the bandwidth.

Gaussian Minimum Shift Keying (GMSK) is a form of MSK where the signal is filtered by a Gaussian filter with a specified Bt. The GSM system is a form of GMSK but this system has a phase accuracy specification rather than a frequency deviation accuracy specification. As a result it is usually not practical to generate GSM signals with an FM system and is usually implemented either by a direct digital synthesizer or an IQ modulator.

## PSK (Constant Amplitude)

Constant amplitude Phase Shift Keying can be used to transmit digital information. As with FSK the digital information is filtered and applied to a phase modulator. The signal has a constant RF level and consequently on an IQ diagram it can be described as a constant length vector which moves either side of the I axis. The modulation format can require that the signal is transmitted with just two possible phase states (binary) or more than one bit at time can be transmitted (QPSK has 4 states derived from 2 bits for each transmitted symbol). Frequency spreading can be limited either with a bandpass channel filter on the RF signal or a low pass filter on the modulation input.

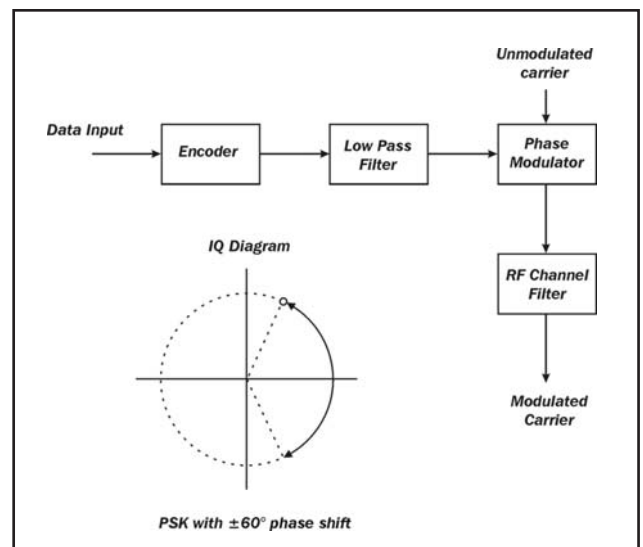

Figure 8 - Constant Amplitude PSK

## Differential PSK (Constant Amplitude)

Differential PSK is a form of PSK where the modulator uses the RF signal generated by the previous data bit as the reference instead of the unmodulated carrier. The difference can be best understood by considering what happens if PSK and Differential PSK using 90° phase shift for a logic 1 input receives a string of 1's.

In PSK the modulator will shift the carrier by 90° and the carrier will remain in this state until a logic 0 is required. The frequency will be the same as the unmodulated carrier.

In differential PSK the previous state is used as the reference point. Consequently a string of 1's results in the phase being incremented by 90° on every data bit. Since the phase is linearly changing with time this is equivalent to a frequency shift so the output frequency is not the same as the unmodulated carrier fre-

quency. In this respect Differential PSK is very similar to FSK, the main difference being that the filter applied to the modulator input has a different effect to FSK due to the difference in weighting between FM and Phase Modulation. The specification on phase accuracy for the system may also result in it being essential that the modulation is generated by a phase modulator and not by a weighted frequency modulator.

### PSK (Non Constant Amplitude)

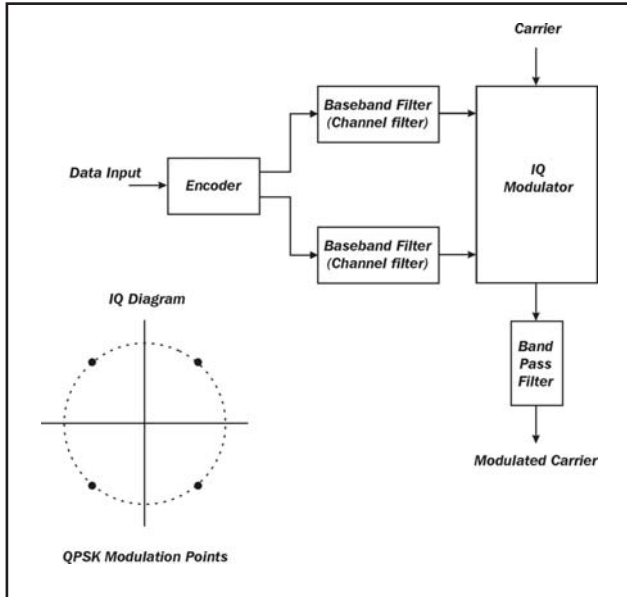

Figure 9 - PSK (Non Constant Amplitude)

In non-constant amplitude PSK the modulation is typically generated by an IQ modulator. The I and Q ports of the modulator will have independent filters, typically of the raised cosine type, to limit the frequency spread. Instead of the signal having a constant RF level the signal vector moves between states in such a way that it deliberately introduces amplitude variations. In general the vector trajectory takes the shortest route between two states. In BPSK systems of this type if the two possible phase states are typically 180° apart and the signal will simply travel along the I axis between the two allowed states. PSK systems can use multi-level formats, such as QPSK and 8PSK.

In general PSK systems are more spectrally efficient than Constant Envelope PSK but may require the use of more linear amplifiers. BPSK signals are often used in satellite control links.

### Differential PSK (Non Constant Amplitude)

Differential PSK is a form of PSK where the modulator uses the RF signal generated by the previous data bit as the reference instead of the unmodulated carrier. The RF level of the carrier is not constant when the modulation is applied. As with constant amplitude PSK and Differential PSK, the difference can be best understood by considering what happens if PSK and differential PSK using 90° phase shift for a logic 1 input receives a string of 1's. In PSK the modulator will shift the carrier by 90° and the carrier will remain in this state until a logic 0 is required. The frequency will be the same as the unmodulated carrier.

In differential PSK the previous state is used as the reference point. Consequently a string of 1's results in the phase being incremented by 90° on every data bit. Since the phase is linearly changing with time this is equivalent to a frequency shift so the output frequency is not the same as the unmodulated carrier frequency. Unlike FSK the system does not have a constant envelope so it cannot be generated with just an FM modulator.

### Differential Phase Offset PSK

Phase offset PSK systems are very similar to PSK systems described above but between symbols the constellation of allowed points on the IQ diagram is rotated by half the separation between adjacent points. The effect is that the number of allowed points is doubled. In QPSK for example there are a total of 8 allowed points in the constellation but only 4 are in use for any particular symbol. Since each point is separated by  $\pi/2$  radians the offset between the two constellations is  $\pi/4$ . Offset PSK systems are inherently differential since each new symbol uses the previous state as its new reference. An example of this modulation is NADC (or North American Digital Cellular) which is  $\pi/4$  offset DPSK.

The advantage of phase offset PSK is that there are no transitions which result in the signal having to travel through the origin of the IQ diagram so at no point does the signal amplitude fall to zero. This can significantly simplify the receiver design.

### QAM

QAM (Quaternary Amplitude Modulation) uses a combination of phase and amplitude modulation to provide a multi-level modulation format. The most common forms are 16QAM and 64QAM where 4 or 6 bits respectively are coded for each transmitted symbol. QAM is usually generated using an IQ modulator and the band limiting filters are applied to the I and Q drives. QAM is generally not used for mobile communications because it is difficult to make the receiver operate reliably in poor propagation conditions, but there is considerable interest in using this type of modulation for terrestrial broadcast of digital television signals.

Some forms of QAM do not use all the constellation points available. For instance, 32 QAM is 64 QAM with the 32 states which represent the largest signal amplitude (i.e. distance from the centre of the IQ diagram) removed to restrict the maximum signal amplitude.

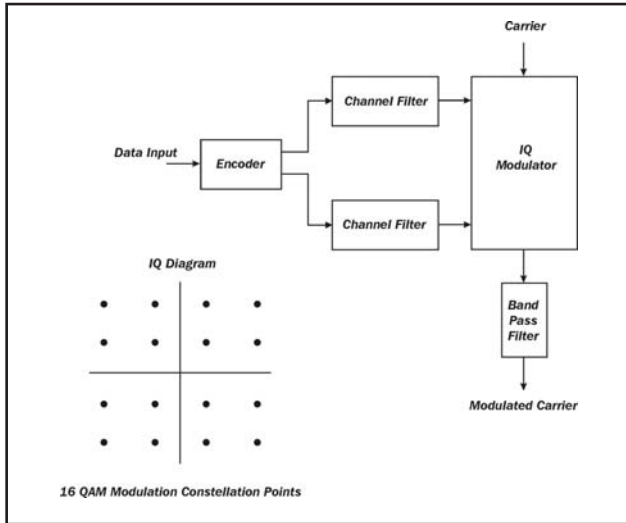

Figure 10 - QAM Modulation

### Time Offset QAM

Time offset QAM is a variation of the normal QAM format but the I and Q drives are arranged such that the signal applied to the Q axis is delayed by half a symbol period compared to that applied to the I channel. This prevents the carrier signal going through the origin of the IQ diagram when moving between states and hence eliminates carrier disappearances. Consequently the demodulation process is more robust than conventional QAM.

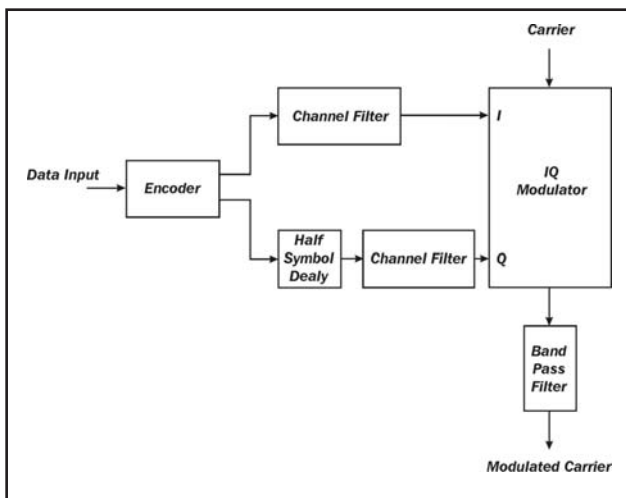

Figure 11 - Time Offset QAM

Time offset QAM will be used for the next generation of ground to air communications for the transmission of telemetry information from commercial aircraft. There is also interest in using the system for airborne telephone applications, particularly in the USA.

### Star QAM

Star QAM uses a circular constellation rather than a square constellation of allowed phase and amplitude states. In a typical 16 Star QAM system a constellation consists of two concentric circles each containing 8 allowed states. Since the circles represent con-

stant carrier levels the constellation is defined as having two allowed amplitudes combined with 8 allowed phases. The advantage of this system is that unlike QAM the signal has only two allowed amplitudes. The signal is coded to ensure that both level conditions are heavily used and consequently the receiver can actively continually "monitor" the two allowed level states and compensate for their variation in fading propagation conditions. This may enable this modulation system to be used for future mobile communications.

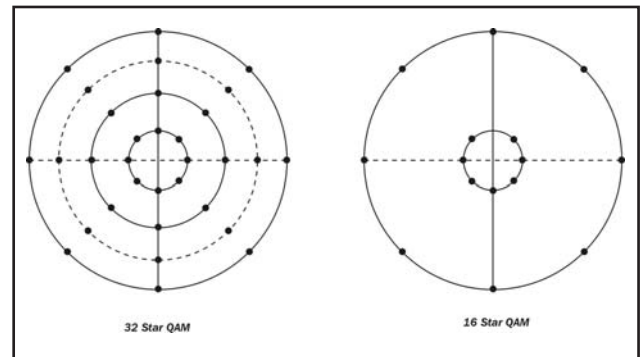

Figure 12 - Star QAM

### Sub Carrier Systems

A variety of schemes provide digital modulation by generating a sub-carrier, or tone, which is modulated by a digital signal. The simplest example is probably Frequency Frequency Shift Keying (FFSK) where a tone is switched between two frequencies, for instance 1.2 kHz and 1.8 kHz. There are also schemes where almost any of the above modulation techniques can be imposed on a sub-carrier and either amplitude modulated or, more usually frequency or phase modulated, on to the RF carrier.

### Multi-Carrier Signals

There are proposals to use modulation techniques where a number of carriers each carry a form of modulation (e.g. QAM, QPSK). The information to be transmitted is distributed amongst the carriers. The next generation of stereo broadcast transmission in Europe (DAB) uses this type of format to transmit the required high data rates. Transmitting information on multiple carriers can offer significant system advantages. The use of several carriers results in the symbol rate being relatively low compared to the data rate. The advantage that this conveys is that the modulation system can be easily designed to be relatively immune to multipath problems. In the case of DAB this allows the setting up of a national broadcast system where the same broadcast information can be transmitted at a single frequency from a variety of transmitters (Single Frequency Network) with seamless handover between transmitters.

Multiple carriers are being used for narrow band as well as wide-band transmission. The RCR 32 system (Japan) uses four 16 QAM carriers to reduce the symbol rate to sixteen times less than the bit rate. The improvement in multipath immunity makes the system well suited to use in urban environments for land mobile applications.

## Spread Spectrum Modulation

Spread spectrum modulation is a term used to describe a large class of modulation systems. In general spread spectrum signals use a specific modulation system but then deliberately spread the signal over a much wider bandwidth than is required by the data rate. There are a variety of ways of spreading the signal out.

Frequency hop systems simply change the carrier frequency at regular (or irregular) intervals with one of the above forms of modulation on the carrier. The hopping rate can be fast (greater than the data rate) or slow (as in the hopping versions of GSM), but the term spread spectrum is usually associated with those systems where the hopping rate is relatively high. The receiver has to follow the hopping signal and continues to demodulate the carrier to derive the digital (or analog) information. Since the carrier stays in one channel for only part of the time the signal occupies all the available channels and the average transmitted power in each channel is lower than the total transmitted power.

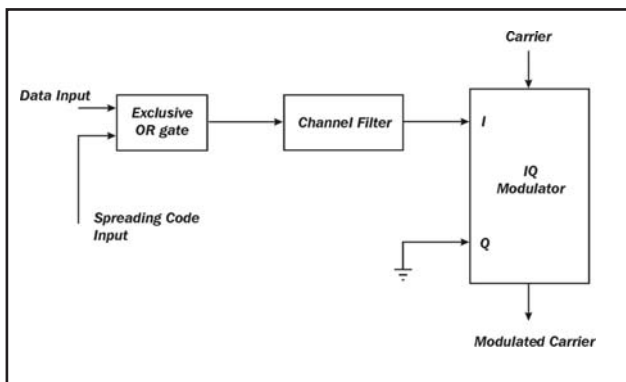

Figure 13 - BPSK Spread Spectrum with Channel Filter

Direct sequence spread signals mix a high frequency digital signal with the required data signal to spread the base band modulating signal out over a wider bandwidth. Typically the spreading system is at least 10 times the data rate and is an integer multiple of the data rate. The spreading signal frequency is called the chip rate. The sequence used to spread the signal has to have special properties to provide the required spectral characteristics. It has to look essentially like white noise to a spectrum analyzer so that the signal is evenly spread but the receiver has to be able to de-spread the signal by applying an identical signal in order to recover the data.

The spread data is applied to a modulator. In principal almost any modulation scheme can be used. Some low cost systems use frequency modulation but BPSK modulation is very common - it is used, for instance, on the Global Position Satellite (GPS) navigation system.

At first sight it is not obvious why a user would want his signal to occupy more bandwidth than it needs to. However the signal does not occupy all the spectrum at the same time. Other users can use the same spectrum at the same time. In direct sequence systems different users use different spreading codes. Consequently the spreading codes have to have the property that the signals they generate do not interfere with each other. The codes also need to allow for a reasonably simple method of get-

ting the receiver de-spreading code synchronized with the incoming signal. For this reason a considerable amount of research effort has been spent on identifying suitable spreading codes.

Direct sequence spread signals can also allow the use of Single Frequency Networks (SFN) where the same information can be transmitted from a number of base stations. A special type of receiver system, a Rake Receiver, allows the radio to pick up a number of the transmitter signals simultaneously and time align them so that the received signal strength is the combined amplitudes of the strongest signal paths. As well as allowing the use of SFN's the Rake receiver provides good immunity to multipath effects.

Direct Sequence Spread Spectrum is claimed to offer the highest spectral efficiency of any digital modulation system since not only is the modulation scheme reasonably efficient but the frequency re-use characteristics are much better than other modulation schemes.

## Fading and Multipath

Radio transmissions are subject to changes in propagation losses from a number of sources. The term fading is used to describe the variation in the propagation loss and different forms of fading are defined to try to match the observed propagation loss variation.

### Slow Fading

Slow fading occurs where the rate of change of loss is relatively low and is typically caused by precipitation (rain or snow) or tropospheric effects. These fading effects are defined as slow if the signal level does not vary significantly over a period of time defined by a time slot in the case of TDD or TDMA signals or over an interval of time longer than that which a typical receiver can compensate for. Generally receivers are not directly tested for their ability to cope with slow fading since allowances are usually made in the system design to allow a receiver to cope with the effect. A sensitivity test is usually adequate to establish that a receiver works satisfactorily.

### Rayleigh Fading

Rayleigh fading occurs where a receiver operates in an environment where the received signal is derived from a series of reflections from a number of objects and there is no significant direct path between the receiver and the transmitter. This is commonly the case with terrestrial transmissions for mobile communications since it is unusual to be able to see the transmitter antenna from the receiver location.

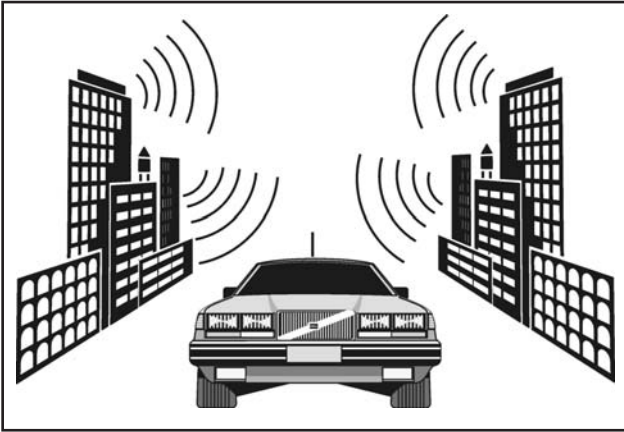

Figure 14 - Rayleigh Fading

The multiple reflections cause complex standing waves to be set up as the various sources interfere with each other. If the receiver is moving with respect to the transmitter or the reflection sources the received signal amplitude and phase will vary as the receiver moves through areas of constructive and destructive interference. The rate of change of amplitude and phase is dependent upon the carrier frequency and the velocity of the receiver as it moves through the field of standing waves. At some points the signals will add together to increase the received signal level and at other points the signal level will drop rapidly as destructive interference is encountered.

Fading signals of this type are a challenge to digital receiver design and such receivers have to be tested during development to establish their performance under these conditions.

### Rician Fading

Rician fading occurs where there is a multiple source of reflected signals but an additional direct path transmission is present because there is direct line of sight access to the transmitter. A classic example of a Rician fading environment is in aircraft communications where the aircraft can be seen but there is a significant reflected signal from surrounding objects (trees, buildings etc.).

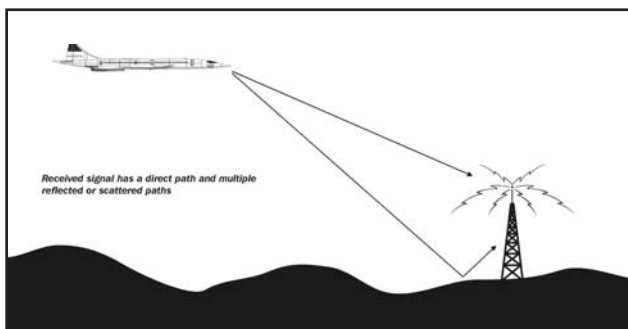

Figure 15 - Rician Fading

As with Rayleigh fading the signal is subject to amplitude and phase variation as the reflected and the direct signal interfere. The rate of change of signal characteristics is dependent upon the receiver speed with respect to the scattered sources and the transmitter, and the relative amplitudes of the direct and indirect (scattered) paths.

### Multipath

The various forms of fading described above occur where the sources of reflected signals result in the signal phase and amplitude being disturbed by reflection sources adding signals which follow a path length significantly different compared to the wavelength of the transmitted signal. Where the difference in path length is very long it can become equivalent to a significant proportion of the distance the signal travels in one symbol period of the digital modulation.

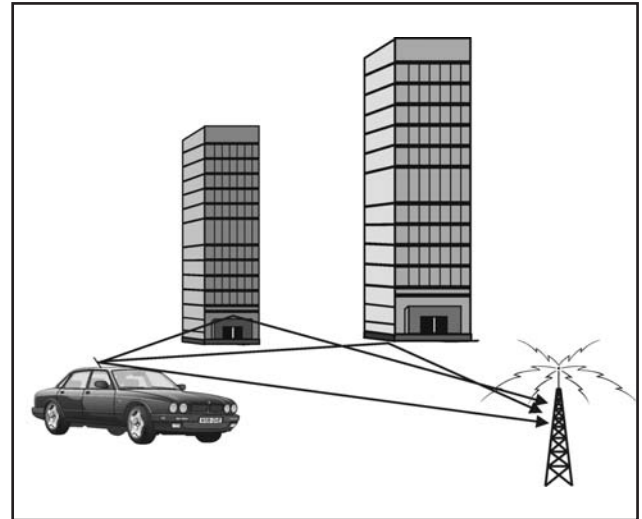

Figure 16 - Multipath

When this happens it is referred to as a multipath signal. The higher the data rate of the digital signal the more likely it is that multipath will be a problem since the relative path difference is shorter in order for the signal to be classed as a multipath signal. For this reason multipath is a more serious potential problem for GSM than for NADC.

Some digital receivers include circuits, often called equalisers, which are specifically designed to eliminate errors caused by multipath signals. These circuits make use of a special sequence of bits (called the Training Sequence on GSM for example) whose content is known. The receiver's circuits effectively quantify the effects of the multipath signals on this sequence and then correct the signal in the rest of the time slot to correct for its effects.

Receivers working with low bit rates (eg pagers) or over short distances (eg cordless telephones) are generally not very likely to experience severe multipath problems and therefore do not include equalisers.

### Structure of Digital Signals

Digital modulation signals are applied to carriers in a highly structured manner in order to allow easy access to the telecommunications network and allow receivers to lock on to the carrier, extract the data clock and decode the data. The details of the structure vary considerably depending on the application and the data rates required. In Europe there is a strong tendency to standardize on a few formats for different applications but in North America there is a greater variety of open and proprietary standards.

Many digital systems endeavour to fit in with existing channel spacing standards but need to support more than one user on an RF channel. For this reason many digital systems use Time Domain Multiple Access (TDMA) to partition the frequency up into different time slots and then allocating each user one time slot. North American Digital Cellular (NADC), for instance currently allows three users per RF channel but will eventually allow six users per channel when half rate codecs are available.

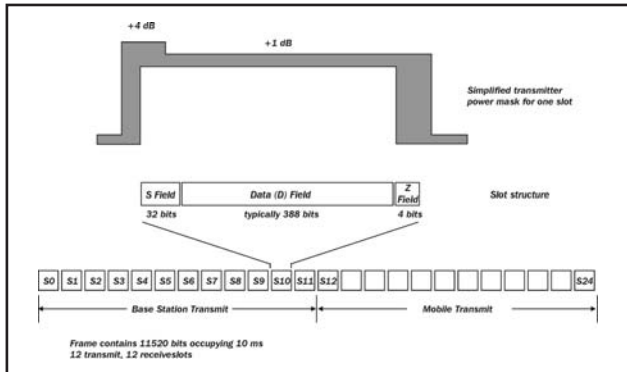

Figure 17 - DECT Data Structure

An example of a digital modulation is the Digital European Cordless Telephone (DECT). This system is intended for cordless telephone and wireless Local Area Network (LAN) applications so is capable of transmitting speech or data. The system uses Time Domain Duplex (TDD) ie the transmission and receive frequencies are the same so a transceiver has to receive a signal at a different time compared to when it transmits information. It also uses Time Domain Multiple Access (TDMA) ie more than one user has simultaneous access to the same carrier frequency so each user is allocated a different time to transmit and receive.

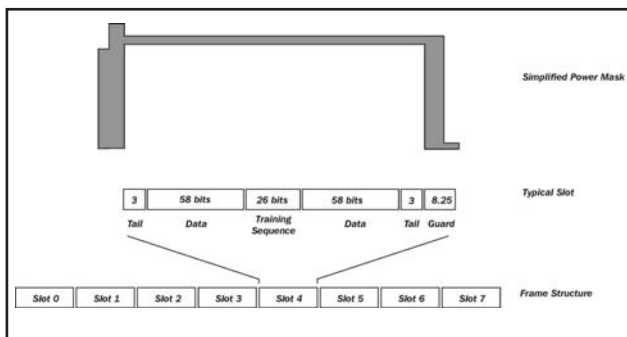

Figure 18 - GSM Structure

The smallest allowed block of data is a time slot. A time slot is allocated to one user only and typically starts with a time interval where the user increases his transmitted (or received) power from zero to his nominal operating power level in a controlled way to ensure that the resulting RF spectrum does not interfere with other users. There will then be a time when preset information is sent to allow the receiver to settle and synchronise with the transmitter, followed by the burst of useful data to be sent and then a corresponding interval where the power is ramped down.

DECT does not use a training sequence, but systems which do require one will contain the training sequence somewhere in the

information part of the signal. In GSM, for instance, the training sequence is in the middle of the data burst. The useful data section will also contain information to advise the receiver what type of data is being transmitted and provide control information.

Time slots are organized into frames. In the case of DECT there are 12 potential users of a single carrier each of whom needs one transmission slot and one receive slot so there are 24 slots to a frame. DECT systems also have a mode of operation which allows one user to take all the vacant time slots if the user is sending data in order to minimize the data transfer time.

Frames are organized into multiframes and superframes. If a receiver is required to carry out a specific action a superframe usually needs to be sent to provide enough information and execute the task.

The precise structure of a time slot and the higher level structures may change according to what the receiver is trying to do. If, for instance, a receiver is trying to synchronize to a base station transmitter it may have to transmit a shortened time slot to ensure that the propagation delay does not result in the signal interfering with other users. When the shortened burst is received the base station will advise the receiver how much to change the slot timing in order to ensure that it is received at the base station at the correct time. As a result of these requirements many digital systems will have a number of allowed structures other than the one that is used in normal information transfer.

### Adjacent Channel Power

The need to raise and lower the RF signal level can cause the frequency spectrum of the digitally modulated signal to spread as observed by a spectrum analyzer. For this reason the rate of rise and fall of the signal has to be controlled. Too fast a rise time results in spectrum spread and too slow a rise time results in lost information bits. For this reason all digital systems specify a power mask (RF power versus time) too which the signal must conform. Some of the spectral spread is of little consequence in an all digital system since if all the carriers raise and lower their signal levels at the same time no information is being sent over the system. For this reason gated spectrum analysis measurements are sometimes used too separate out the modulation and the RF burst aspects of the RF spectrum.

Other forms of errors can have more significant effect on the frequency occupancy of the system, particularly in the adjacent channel. Modulation systems based on raised cosine type filters in theory have very low spectral occupancy since there is (in theory) no signal power above the symbol rate. In practice finite accuracy of the vector IQ drive signals, amplitude to phase conversion errors in the modulator and compression in the power amplifiers will cause the RF spectrum of the signal to spread beyond the symbol rate of the system.

For the very latest specifications visit [www.aeroflex.com](http://www.aeroflex.com)

**CHINA Beijing**

Tel: [+86] (10) 6539 1166  
Fax: [+86] (10) 6539 1778

**CHINA Shanghai**

Tel: [+86] (21) 5109 5128  
Fax: [+86] (21) 5150 6112

**FINLAND**

Tel: [+358] (9) 2709 5541  
Fax: [+358] (9) 804 2441

**FRANCE**

Tel: [+33] 1 60 79 96 00  
Fax: [+33] 1 60 77 69 22

**GERMANY**

Tel: [+49] 8131 2926-0  
Fax: [+49] 8131 2926-130

**HONG KONG**

Tel: [+852] 2832 7988  
Fax: [+852] 2834 5364

**INDIA**

Tel: [+91] 80 5115 4501  
Fax: [+91] 80 5115 4502

**KOREA**

Tel: [+82] (2) 3424 2719  
Fax: [+82] (2) 3424 8620

**SCANDINAVIA**

Tel: [+45] 9614 0045  
Fax: [+45] 9614 0047

**SPAIN**

Tel: [+34] (91) 640 11 34  
Fax: [+34] (91) 640 06 40

**UK Burnham**

Tel: [+44] (0) 1628 604455  
Fax: [+44] (0) 1628 662017

**UK Cambridge**

Tel: [+44] (0) 1763 262277  
Fax: [+44] (0) 1763 285353

**UK Stevenage**

Tel: [+44] (0) 1438 742200  
Fax: [+44] (0) 1438 727601  
Freephone: 0800 282388

**USA**

Tel: [+1] (316) 522 4981  
Fax: [+1] (316) 522 1360  
Toll Free: 800 835 2352

As we are always seeking to improve our products, the information in this document gives only a general indication of the product capacity, performance and suitability, none of which shall form part of any contract. We reserve the right to make design changes without notice. All trademarks are acknowledged. Parent company Aeroflex, Inc. ©Aeroflex 2006.

[www.aeroflex.com](http://www.aeroflex.com)  
[info-test@aeroflex.com](mailto:info-test@aeroflex.com)



Our passion for performance is defined by three attributes represented by these three icons: solution-minded, performance-driven and customer-focused.

Part No. 46891/863, Issue 1, 02/07