

Application Note



Extending test capabilities of the PXI 3000 RF test solution with 3060 Series RF combiner modules



The purpose of this application note is to present the use of the 3060 Series PXI RF combiners under different application scenarios common to RF device testing. The various modules available within the 3060 family extend PXI 3000 capability to test a wide variety of DUT topologies. In some cases the addition of a simple RF combiner to the PXI system will increase system performance and efficiency in a more effective manner than through the addition of external components.

Introduction

This application note is targeted towards the audience of global R&D and manufacturing RF test engineers and system designers.

In addition to providing the summing of signals, the 3060 Series modules support various input and output switched path configurations to enable testing of single port and multi-port RF devices and to enable test system internal calibration without the need to disconnect the test subject. The use of high speed electronic Switches in 3060 Series RF Combiners provides more reliable and faster switching than products based on mechanical switching. This feature makes the 3060 Series RF Combiners ideally suited for applications where high speed and repetitive switching is essential. Various configurations supported by 3060 Series enable PXI 3000 to provide flexibility to cope with future changes to DUT without the need of any additional components.

APPLICATIONS

The 3060 Series are designed for use in a variety of radio test applications, in the frequency range up to 2.7 GHz. The main applications include:

- Testing transceivers with or without diversity Rx
- Intermodulation testing
- Receiver selectivity and blocking test
- Simultaneous in band/out of band transmitter testing
- Simultaneous testing of multiple DUTs
- Testing of multiple transceivers in a single DUT
- Testing radios with single port duplex or dual port duplex interfaces
- Dual transceiver device test
- Simultaneous testing of two diversity transceivers
- Testing MIMO devices with 2Tx and 3Rx

3060 APPLICATIONS

3060 is a 3 input RF combiner/RF switch assembly.

Transceiver Testing

In this configuration, shown in Figure 1, the SUM port acts as a single port duplex connection point with one or two RF sources providing Rx stimulus input(s) and an RF signal analysis instrument connected to the third input port to measure DUT Tx parameters. High port to port isolation ensures low intermodulation and good isolation between source and analyzer to prevent interference e.g. self blocking.

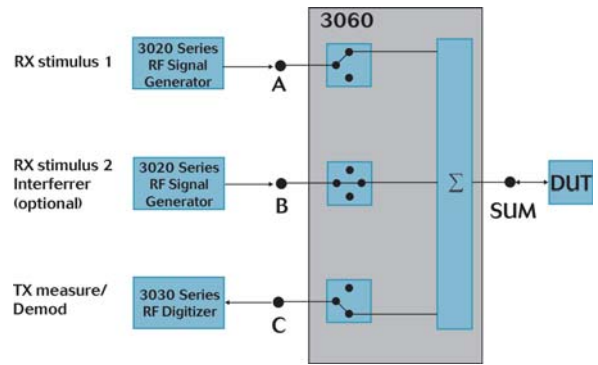

Figure 1. Transceiver testing using 3060 RF Combiner

Receiver Selectivity and Blocking Test

As shown in Figure 1, the 3060 enables two RF Signal Generators to be connected simultaneously to the DUT thus supporting receiver selectivity and blocking tests.

Intermodulation Testing

For intermodulation testing, two or three ports can be used to combine RF source inputs to a common DUT test port. In this case the DUT output port would be directly connected to the analysis instrument such as a 3030 Series VSA (Vector Signal Analyzer). The high isolation between each input port ensures any intermodulation distortion in the output stage of the signal generators is minimized. To further improve the system's intermodulation distortion, additional attenuation can be added between the signal generators and the combiner, resulting in higher isolation.

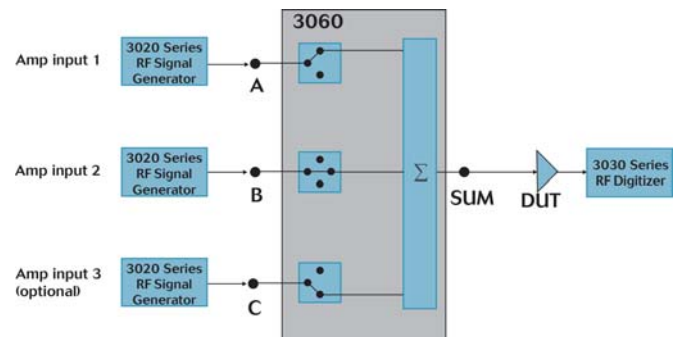

Figure 2. Receiver and amplifier intermod testing using a 3060 RF combiner

Simultaneous In Band/Out of Band Transmitter Testing

In a similar fashion, simultaneous in-band and out-of-band transmitter measurements can be performed by connecting a pair of RF Digitizers to the DUT. Stimulus is provided by a RF signal generator in the third input port.

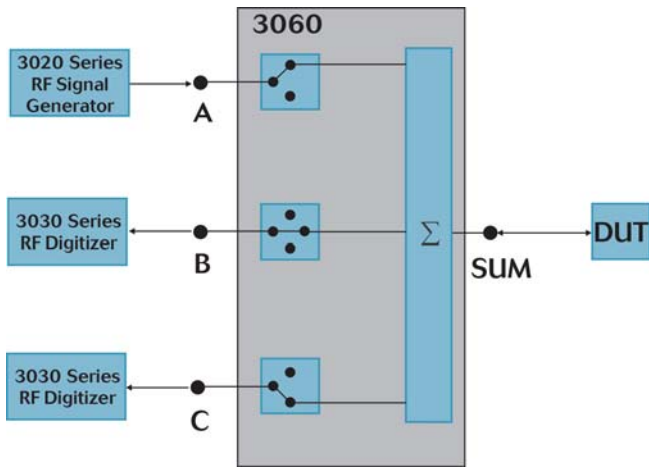

Figure 3. Simultaneous in band/out of band transmitter testing

Dual Port Duplex with Diversity Rx Transceiver Tests

Testing transceivers with diversity Rx using a 3060 can be performed by using two 3020 Series RF signal generators, one connected to the A port of the 3060 and the other to the Rx port of the DUT. A 3030 Series RF Digitizer connected to Port C can be used to capture the Tx response of the DUT.

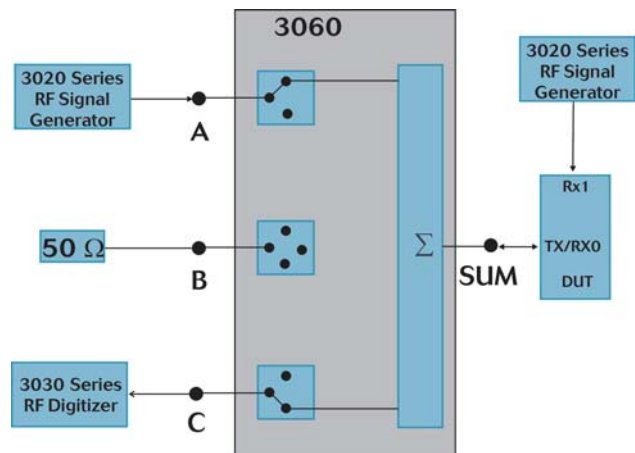

Figure 4. Testing transceivers with diversity Rx using 3060

The same test can be performed with a single 3020 Series signal generator. In this case, the signal from the 3020 Series VSG (Vector Signal Generator) is routed from port C to B to reach the diversity receiver in the DUT. Port C can be switched back to SUM to test the primary receiver port.

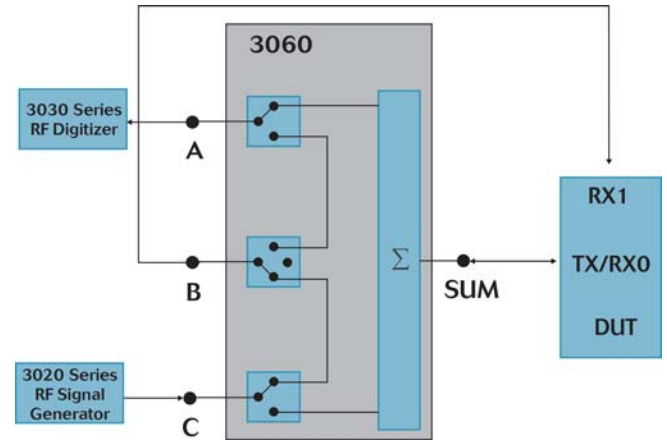

Figure 5. Testing transceivers with diversity Rx from a single signal generator

Maximum Sensitivity and Maximum Power Handling for Single Port Duplex Transceiver Test

Using an external SPDT (Single Pole Double Throw) switch, the following measurements can be performed without the need to disconnect the device under test:

- Maximum sensitivity measurements
- Maximum power handling measurements
- Low level Rx tests
- Tx maximum output test

When the external switch routes the DUT's Duplex port (Tx/RX) to port B, a low loss path (only 2 dB) to the digitizer is established using the "A to B and C to SUM" configuration improving sensitivity for measuring low level Tx parameters such as Tx Off Power in TDMA TDD systems. Maintaining the external switch connection and setting the 3060 to the "C to B and A to SUM" configuration, the signal of up to 24 dBm from the 3020 Series VSG can be applied to enable maximum power handling measurements.

Alternatively, when the external switch connects the DUT to the SUM port, and the 3060 is set to "All to SUM", a 15 dB loss exists through the internal path. This setup creates a single duplex port that allows low level Rx tests and maximum Tx output tests with a signal of up to 30 dBm applied at the SUM port.

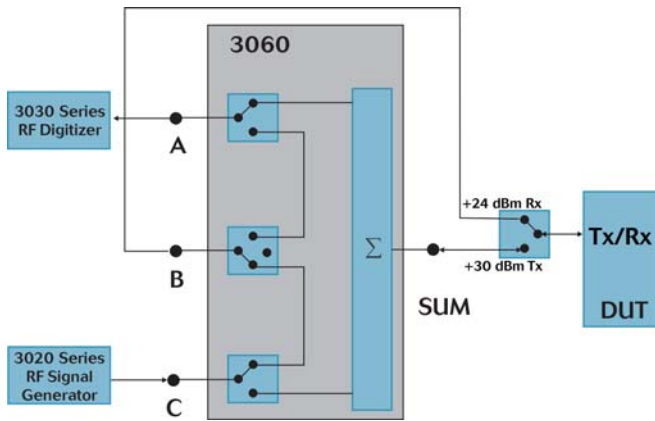

Figure 6. Single port duplex transceiver test showing maximum power handling measurement

Dual Transceiver Device Test Using the 3060

By adding 2 SPDT RF switches, the 3060 makes it possible to connect a 3020 Series VSG/3030 Series VSA resource to all RF connections of dual transceiver, multi-band devices. Sequential Tx and Rx measurements for each band can be performed under such configuration. With the 3060 configured to output the 3020 Series VSG to port C the diversity RX branches can be measured. This transceiver configuration is typically found in WLAN products featuring 2.4 GHz and 5.8 GHz transceivers each with diversity receive channel, in which case a 3065 RF Combiner must be used to allow testing at frequencies over 2.7 GHz.

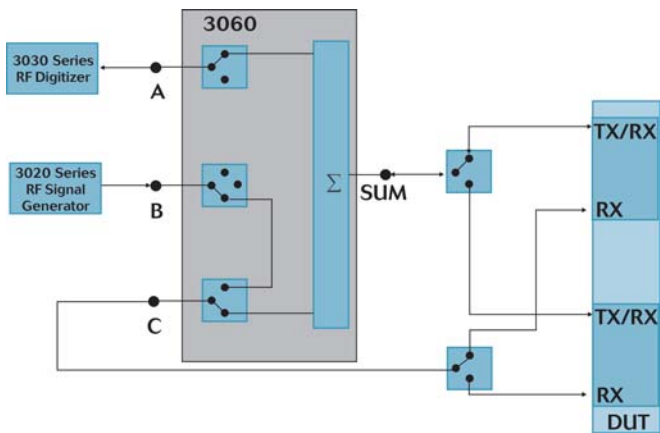

Figure 7. Dual transceiver device test

3061 APPLICATIONS

The 3061 has been carefully designed for cellular mobile phone test applications up to 2.7 GHz.

Unlike the 3060/3065, the 3061 is designed to accept input levels up to +33 dBm at SUM 1, 2 and 3 while ensuring that any Aeroflex PXI RF modules connected to the 3061 input is not overdriven.

Simultaneous Testing of Three DUTs

3061 enables connection of a RF signal generator and RF digitizer pair to 3 separate devices simultaneously thus reducing handling time and in some cases it reduces overall test time where Rx testing can be done in parallel.

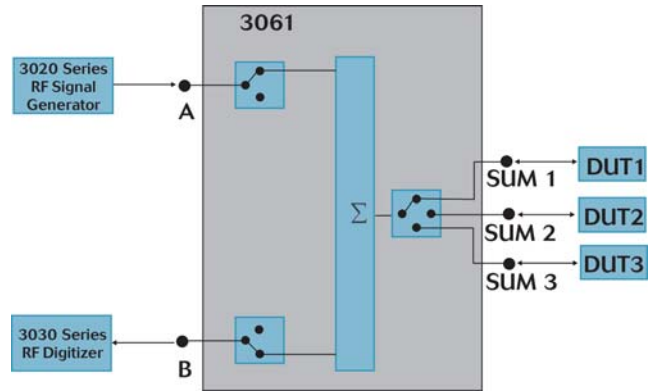

Figure 8. Simultaneous testing of three DUTs

Testing of Multiple Transceivers in a Single DUT

The 3061 can also be used to sequentially test multiple transceivers in a single device simplifying test set up.

For example, a mobile handset featuring WLAN, Bluetooth and cellular interfaces can be tested under a single set-up. Alternatively the 3061 can be used to support up to 3 x 3 MIMO in Multiple-Input Multiple-Output test applications.

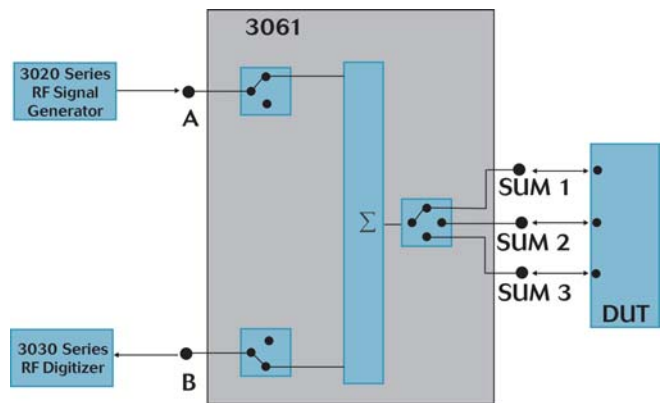

Figure 9. Testing of multiple transceivers in a single DUT

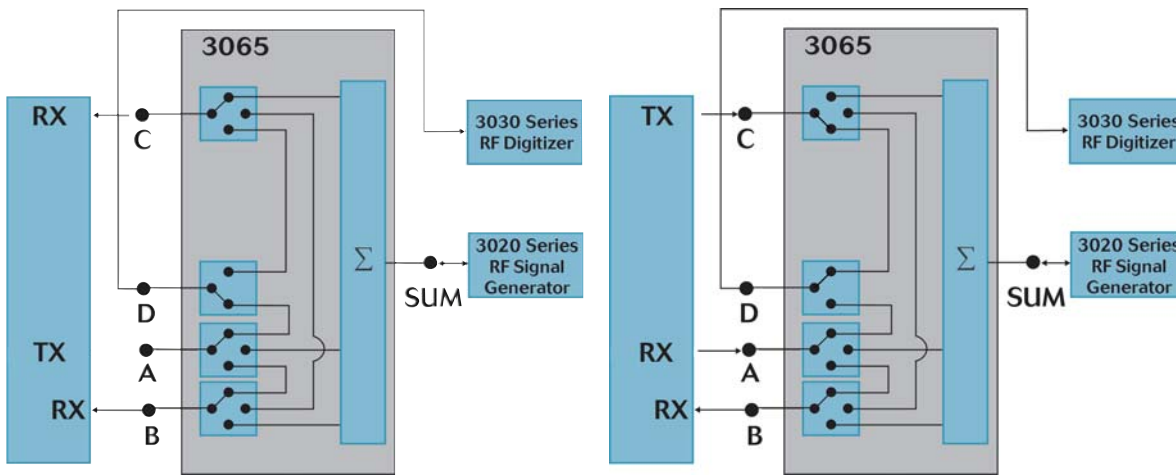

Figure 12: 2Tx/3Rx handset transceiver test

Dual Transceiver Test Using the 3065

As an alternative to the 3061, two 3065 RF combiners are capable of performing dual transceiver tests when connected in the configuration shown in Figure 13. The image shows the two states of the dual transceiver test process.

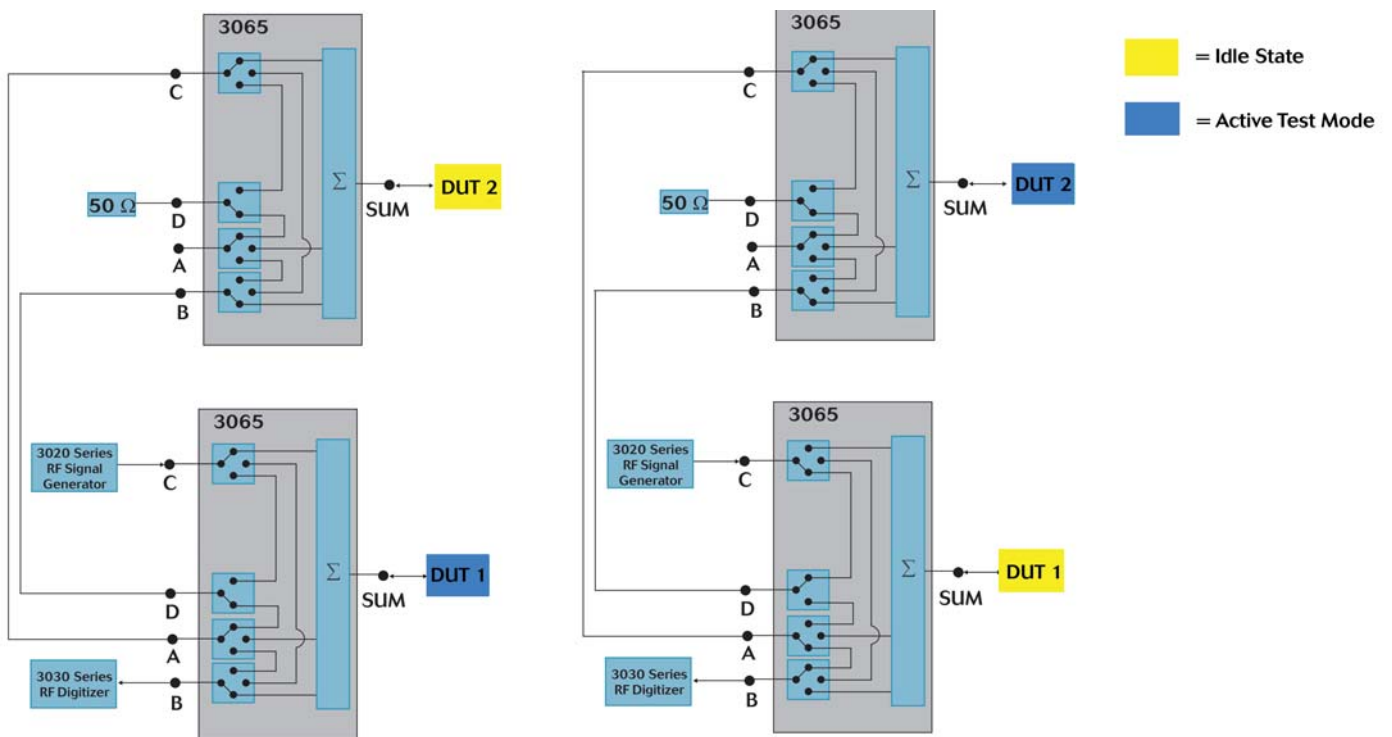

Figure 13. Dual transceiver test

Triple Transceiver Test Using 3065

Triple transceiver tests can also be achieved using two 3065 RF combiners connected through their SUM interfaces. To maximize resource usage and efficiency when testing three DUTs, a 3061 needs to be used (see Figure 8). With 3065 configuration (see figure 14) the system loss makes it only suitable for conducting DUT Rx low level signal tests.

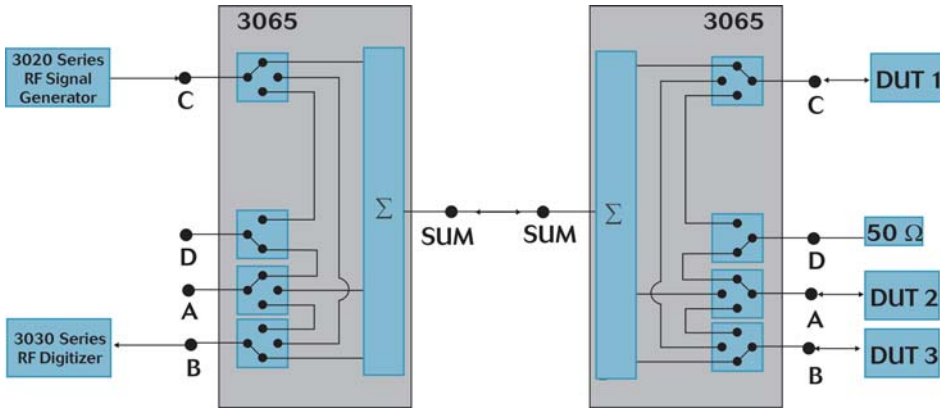

Figure 14. Triple transceiver test

Dual Transceiver Test Using the 3065 or 3065A

The additional port D on 3065 and 3065A allow them to be configured as a 2x2 cross port multiplexer. One application for this is to simultaneously test Tx and Rx of two transceivers. In this configuration, shown in figure 15, port B and D act as duplex connection points with Rx Stimulus input provided by 3020 Series RF Signal Generator connected at C port and the DUT's Tx parameters measured by 3030 Series RF Digitizer connected to Port A.

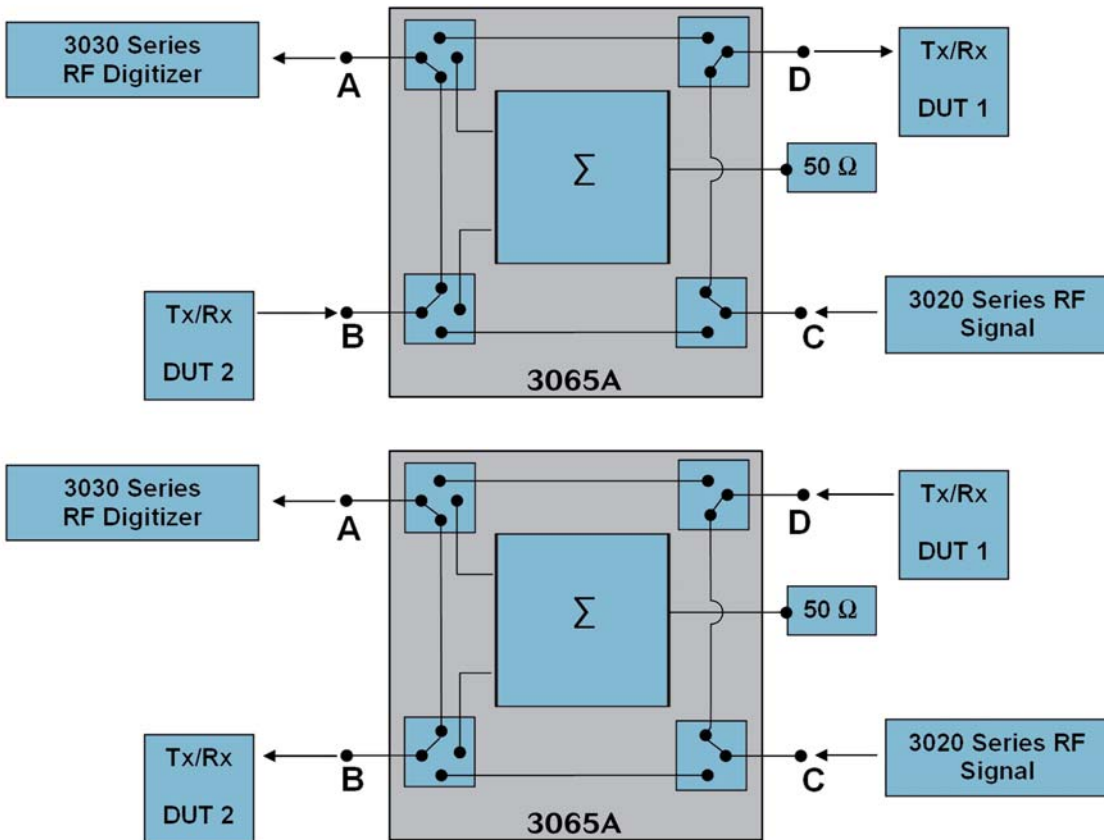

Figure 15 Dual transceiver test using 3065A

When DUT1 is transmitting, the Tx signal is routed from ports D to A through the internal switches, and likewise, if DUT2 is transmitting, the Tx signal is routed through port B to A. The 3030 Series RF Digitizer connected to port A is used to analyse the Tx signals. The 3020 RF signal generator connected at port C, can be used to stimulate the DUT not being used for Tx to perform concurrent Rx measurements.

Note: For concurrent test approach to provide maximum benefit it would be essential for DUT's to have comparable Rx and Tx measurement times.

Configurations

Following are the switched path configurations achievable with the 3060 Series RF combiners:

3060

1. A,B,C to SUM
2. A-B, C to SUM
3. C-B, A to SUM

3061

1. A,B to SUM 1 (SUM 2,3 terminated)
2. A,B to SUM 2 (SUM 1,3 terminated)
3. A,B to SUM 3 (SUM 1,2 terminated)
4. A-B (SUM 1,2,3 terminated)

3065

1. A,B,C to SUM
2. A-B, C to SUM
3. C-B, A to SUM
4. A-D, B,C to SUM
5. C-D, A,B to SUM
6. A-D, B-C
7. A-B, D-C

3065A

1. A,B to SUM, C-D
2. A-B, C-D
3. A-D, B-C

These configurations are further clarified through the diagrams presented in the following pages for each of the PXI RF conditioning modules that make up the 3060 Series.

3060 Switched Path Configurations

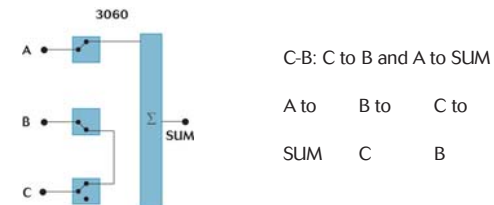
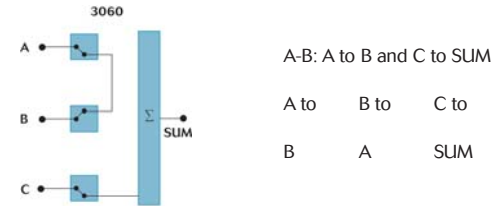
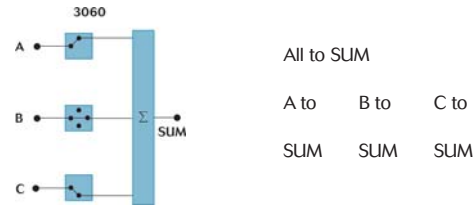

3061 Switched Path Configurations

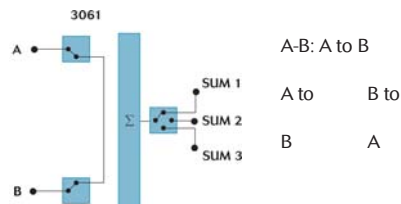
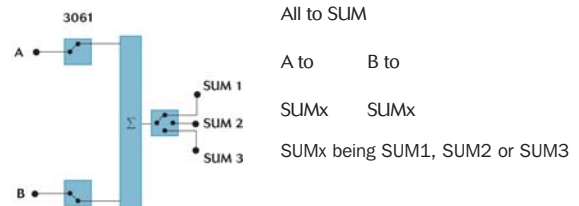

3065 Switched Path Configurations

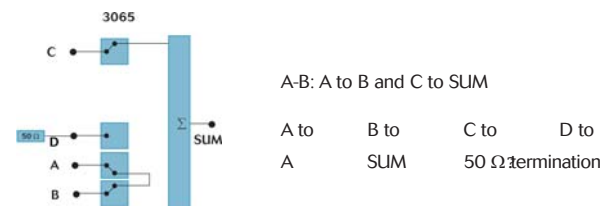
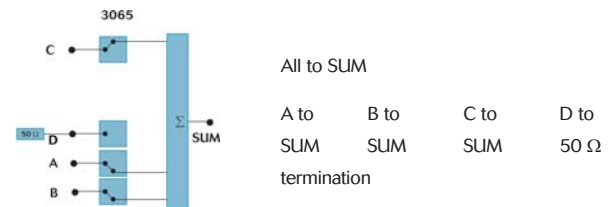

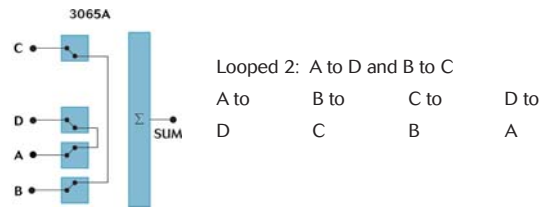
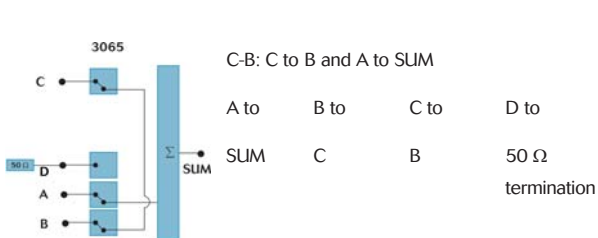

Conclusion

The applications presented show a variety of simplex, duplex and diversity test scenarios frequently encountered when testing wireless devices. This demonstrates the added flexibility the 3060 Series PXI RF Combiners can provide to the Aeroflex PXI 3000 test system while minimizing complexity and reducing the number of external fixtures.

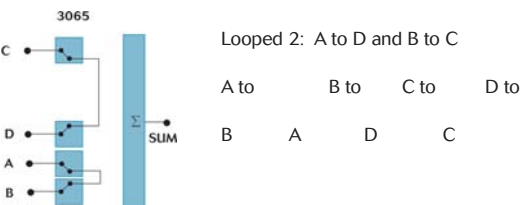
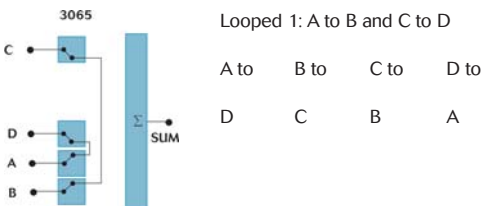
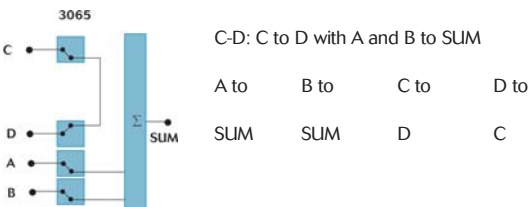
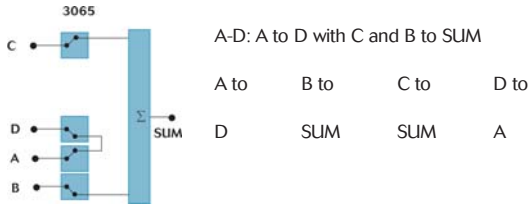

3065A Switched Path Configurations

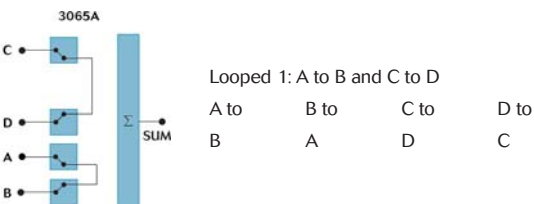
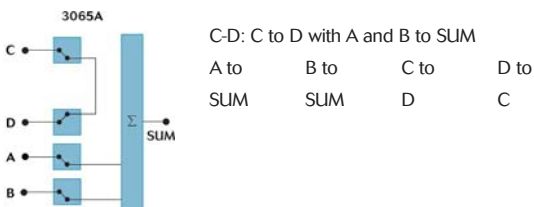

CHINA Beijing

Tel: [+86] (10) 6539 1166
Fax: [+86] (10) 6539 1778

CHINA Shanghai

Tel: [+86] (21) 5109 5128
Fax: [+86] (21) 5150 6112

CHINA Shenzhen

Tel: [+86] (755) 3301 9358
Tel: [+86] (755) 3301 9356

FINLAND

Tel: [+358] (9) 2709 5541
Fax: [+358] (9) 804 2441

FRANCE

Tel: [+33] 1 60 79 96 00
Fax: [+33] 1 60 77 69 22

GERMANY

Tel: [+49] 89 99641 0
Fax: [+49] 89 99641 160

HONG KONG

Tel: [+852] 2832 7988
Fax: [+852] 2834 5364

INDIA

Tel: [+91] 80 [4] 115 4501
Fax: [+91] 80 [4] 115 4502

JAPAN

Tel: [+81] (3) 3500 5591
Fax: [+81] (3) 3500 5592

KOREA

Tel: [+82] (2) 3424 2719
Fax: [+82] (2) 3424 8620

SCANDINAVIA

Tel: [+45] 9614 0045
Fax: [+45] 9614 0047

SINGAPORE

Tel: [+65] 6873 0991
Fax: [+65] 6873 0992

UK Stevenage

Tel: [+44] (0) 1438 742200
Fax: [+44] (0) 1438 727601
Freephone: 0800 282388

USA

Tel: [+1] (316) 522 4981
Fax: [+1] (316) 522 1360
Toll Free: 800 835 2352



As we are always seeking to improve our products, the information in this document gives only a general indication of the product capacity, performance and suitability, none of which shall form part of any contract. We reserve the right to make design changes without notice. All trademarks are acknowledged. Parent company Aeroflex, Inc. ©Aeroflex 2011.

www.aeroflex.com
info-test@eroflex.com



Our passion for performance is defined by three attributes represented by these three icons: solution-minded, performance-driven and customer-focused.