

Power Splitters & Dividers



- /// Broadband Frequency Range - dc to 40 GHz
- /// Widest Selection of connector types & Frequency
- /// **Express** shipment available on select models.
- /// 4-Way Designs Available
- /// High Quality Construction & Connectors
- /// Stable - Low temperature and power coefficients ensure operating stability.
- /// Custom Designs Available on Request - Just contact us with your special requirement...
 - Broadband High Power
 - Low SWR\Return Loss
 - Unique Packaging

General Information



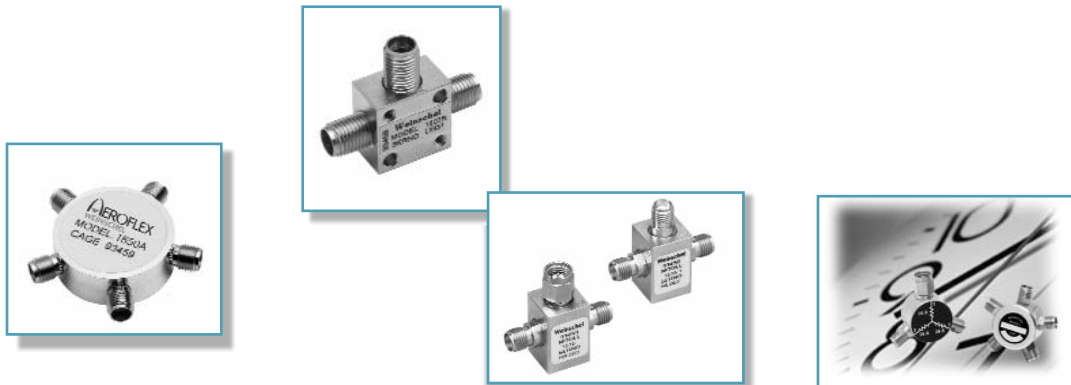

In this section of the catalog, each Resistive Power Splitter/Divider & Directional Coupler is outlined utilizing individual data sheets containing product features, specifications and outline drawings. These data sheets are preceded by a quick reference guide to help you select the product(s) that fits your needs. The page number for each product data sheet is given in the quick reference guide.

Aeroflex / Weinschel offers a comprehensive product line of Power Dividers, and Power Splitters. Many of these standard products were designed for particularly demanding broadband requirements, SWR, and high power system applications. As with the development of all Aeroflex / Weinschel products, high performance at competitive prices is of paramount importance.







NOTE: **EXPRESS** Shipment available via www.argosysales.com or 800-542-4457. Check with distributor for current products and stocking quantities.



Resistive Power Splitters...dc-40.0 GHz

Model Number	Frequency Range (GHz)	Connector Type	Maximum SWR		Maximum Insertion Loss (dB)	Amplitude Tracking (dB MAX)	Phase Tracking (\pm°)	Average Input Power (W)	Page No.	
			INPUT	OUTPUT						
★ 1507R	dc-4.0	2.92mm (f) all	1.15	1.25	6.5	<0.20	<4.0	1	205	
★ 1579	dc-26.5	3.5mm (f) al	1.50	1.45	8.5	0.40	5.0	0.5	207	
★ 1593	dc-26.5	3.5mm (f) al	1.25	1.35	8.5	0.25	4.0	0.5	209	
★ 1534	dc-40.0	2.92mm (f) all	160	160	10.5	0.50	4.0	1.0	210	
★ 1870A	dc-18.0	N (f) all	1.15	1.15	7.5	0.20	2.0	1	208	

Resistive Power Dividers...dc-40.0 GHz, 2-Way & 4-Way

Model Number	Frequency Range (GHz)	Connector Type	Maximum SWR		Maximum Insertion Loss (dB)	Amplitude Tracking (dB MAX)	Phase Tracking (\pm°)	Average Input Power (W)	Page No.	
			INPUT	OUTPUT						
★ 1506A	dc-18.0	N(m) IN (f) OUT	1.35	1.35	7.5	0.50	2.0	1	213	
1515	dc-18.0	SMA (m) IN (f) OUT	1.35	1.35	7.5	0.50	5.0	1	212	
★ 1515-1		SMA (f) all								
★ 1549R	dc-4.0	2.92mm (f) all	1.25	1.25	6	<0.20	<4.0	1	211	
★ 1550A (4-way)	dc-3.0	SMA (f) all	1.25	1.25	13.5	0.50	10.0	1	216	
1575	dc-40.0	2.92mm (f) all	1.70	1.70	8.5	<0.25-0.50*	2.0-5.0*	1	215	
★ 1580	dc-26.5	3.5mm (m) IN (f) OUT	1.25	1.25	8.5	0.20	8.0**	1	214	
1580-1		3.5mm (f) all								
★ 1594 (4-way)	dc-18.0	3.5mm (f) all	1.30	1.30	14.5	2.50	50.0	2	216	

(f) denotes female & (m) denotes male.

* Varies with Frequency.

** Maximum between any two output ports

★ EXPRESS Shipment available via www.argosysales.com or 800-542-4457.

Note: Other models may also be available from Express delivery.

Frequently Asked Questions about Power Splitters & Dividers. . .

What Types of power splitters and dividers does Weinschel offer?

Weinschel offers a variety of broadband (dc-40 GHz) resistive power splitters and dividers with Type N, SMA, 3.5mm, 2.92mm connector options. Power Dividers are available in 2 and 4 way configurations.

How does a resistive power splitter work?

Our resistive power splitters are intended for applications in which one of the two outputs are included in a leveling loop or used as a reference in a ratio measurement system, for the purpose of providing an output signal whose source impedance is essentially matched to 50 ohms. A basic design consists of three ports with a resistor on each of the two output ports, and is a unidirectional device.

What are some applications for a resistive power splitter?

Resistive power splitters provide exceptional amplitude tracking and a very low equivalent output SWR over very broad frequency ranges. They are used in applications in which one of the two outputs is included in a leveling loop or as a reference in a ratio systems such as:

- /// A dual channel insertion loss measuring system where the resistive power splitter provides reference and a signal channel.
- /// A precision power source where a power meter of known characteristics is used, either by ratio or leveling to provide a calibrated output.
- /// Provide a sampled output used for leveling a signal source - for instance in single channel attenuation measurements.

What applications use resistive power dividers?

- /// Broadband independent signal sampling - used in systems to simultaneously measure two different characteristics of one signal such as frequency and power.
- /// Distribution of a low power signals to two or more antennas.
- /// Laboratory measurements where a reference signal exactly tracking the reference signal is required.
- /// Resistive power dividers can be used as power combiners because they are bidirectional.

When do I use a power splitter or divider?

In simple terms many are confused as to the difference between power splitters and power dividers. Here is some basic information that we hope will help.

Power splitters are only used in a ratio systems or leveling loop.

- /// Power splitters can never be used to combined power. They are unidirectional.
- /// A basic power splitter has two resistors and three ports. Power dividers should not be used in ratio and leveling loop application because a mismatch condition of nominally 3:1 would exist.
- /// Power dividers can be used as power combiners because they are bi-directional. Power dividers can be used in a system to simultaneously measure different characteristics of one signal such as frequency and attenuation, power splitters can not.
- /// A basic power divider has three resistors and three ports. A simple description of the circuit shows that any one of the three ports has 50 ohm input impedance when the others are terminated in 50 ohms. The insertion loss between any two ports is 6 dB.



What is a Resistive Power Divider?

An equivalent circuit of the resistive divider is shown below. A simple analysis of this circuit will demonstrate that any one of the three ports has a 50 ohm input impedance when the other two are terminated in 50 ohms, and that the insertion loss between any two ports is 6 dB. A microwave network of this type consists of a symmetrical resistive film deposited on a ceramic substrate having three conducting contacts, each connected to the center conductor of a coaxial connector. Resistive dividers provide well-matched signals of essentially equal magnitude and phase over a very broad band as opposed to the reactive and hybrid types which employ frequency limitive techniques. The resistive divider is intended for applications where the output signals are used independently, such as the simultaneous monitoring of power and frequency.

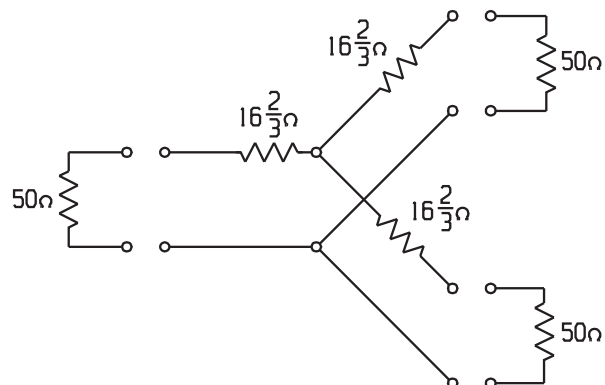

Model 1507R Broadband Resistive Power Splitter (Matching)

dc to 4.0 GHz
1 Watt

Low Cost, 2.92mm Connectors

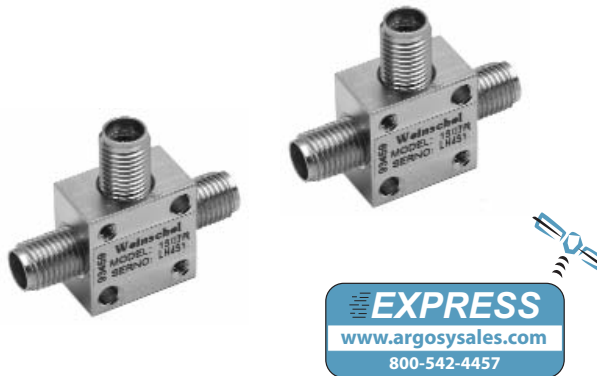

MAXIMUM SWR:

Frequency (GHz)	Output*	Input
dc -4	1.15	1.25

*Equivalent output SWR when used in a leveling or ratio system.

TEMPERATURE RANGE: -55 °C to +125 °C

CONNECTORS: Female 2.92 mm (SMA compatible) connectors all ports--mate nondestructively with other SMA, 2.92mm and 3.5mm connectors.

WEIGHT: 25 g (0.9 oz) maximum

PHYSICAL DIMENSIONS:

Features

These resistive power splitters are intended for RF and wireless applications in which one of the two outputs is included in a leveling loop or is used as a reference in a ratio system, for the purpose of providing an output signal whose source impedance is essentially matched to 50Ω. Some examples are:

- /// A dual channel insertion loss measuring system (ratio).
- /// A parallel IF substitution insertion loss measuring system (ratio or ALC loop).
- /// A precision power source (ratio or ALC loop).

Specifications

NOMINAL IMPEDANCE: 50 Ω

FREQUENCY RANGE: dc to 4.0 GHz

INSERTION LOSS: 6 dB nominal, 6.5 dB maximum
(Between input and either output)

MAXIMUM INPUT POWER: 1.0 watt CW (Input connector only)

AMPLITUDE & PHASE TRACKING (Maximum):

Frequency (GHz)	Tracking	
	Amplitude	Phase
dc - 4.0	<0.2 dB	<4°

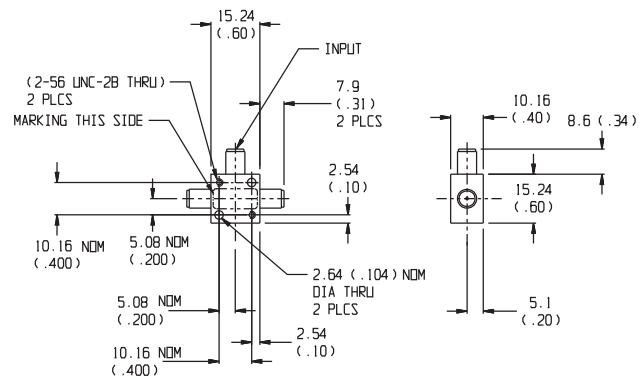

NOTE: All dimensions are given in mm (inches) and are maximum, unless otherwise specified.

Model 1579 Broadband Resistive Power Splitter (Matching)

dc to 26.5 GHz
0.5 Watts

3.5mm Connectors

RoHS



Features

These resistive power splitters are intended for RF and wireless applications in which one of the two outputs is included in a leveling loop or is used as a reference in a ratio system, for the purpose of providing an output signal whose source impedance is essentially matched to 50Ω. Some examples are:

- /// A dual channel insertion loss measuring system (ratio).
- /// A parallel IF substitution insertion loss measuring system (ratio or ALC loop).
- /// A precision power source (ratio or ALC loop).

Specifications

NOMINAL IMPEDANCE: 50 Ω

FREQUENCY RANGE: dc to 26.5 GHz

INSERTION LOSS: 6 dB nominal, 8.5 dB maximum
(Between input and either output)

MAXIMUM INPUT POWER: 0.5 watts CW (Input Connector only)

OUTPUT TRACKING (Between Ports):

Frequency (GHz)	Tracking (maximum dB)
dc - 4	0.15
4 - 8	0.20
8 - 18	0.30
18 - 26.5	0.40

MAXIMUM INPUT SWR:

Frequency (GHz)	Maximum SWR
dc - 26.5	1.50

PHASE TRACKING: ±5° nominal between output ports

EQUIVALENT OUTPUT SWR (Port 2 & 3):

Frequency (GHz)	Maximum SWR
dc - 18	1.25
18 - 26.5	1.45

*When used in a leveling or ratio system.

POWER COEFFICIENT: < 0.005 dB/dB/watt

TEMPERATURE COEFFICIENT: < 0.0004 dB/dB/°C

TEMPERATURE RANGE: -55°C to +125°C

TEST DATA: Insertion Loss, SWR, and Tracking measurements performed across the frequency band. Test data available at additional cost.

CONNECTORS: Female 3.5mm connectors all ports--mate nondestructively with SMA, 2.92mm and other 3.5mm connectors.

CONSTRUCTION: Gold plated brass body; stainless steel connectors; gold plated beryllium copper contacts.

WEIGHT: 30 g (1 oz) maximum

PHYSICAL DIMENSIONS:

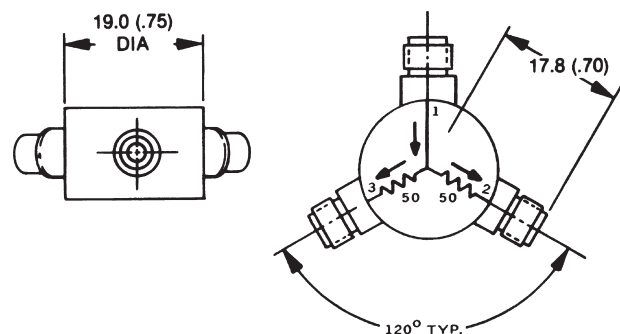

NOTE:

1. All dimensions are given in mm (inches) and are maximum, unless otherwise specified.
2. Unit available with RoHS compliant materials, specify when ordering.

Model 1870A Broadband Resistive Power Splitter (Matching)

dc to 18.0 GHz
1 Watt

Type N Connectors



Features

These resistive power splitters are intended for RF and wireless applications in which one of the two outputs is included in a leveling loop or is used as a reference in a ratio system, for the purpose of providing an output signal whose source impedance is essentially matched to 50Ω. Some examples are:

- /// A dual channel insertion loss measuring system (ratio).
- /// A parallel IF substitution insertion loss measuring system (ratio or ALC loop).
- /// A precision power source (ratio or ALC loop).

Specifications

NOMINAL IMPEDANCE: 50 Ω
FREQUENCY RANGE: dc to 18.0 GHz
INSERTION LOSS: 6 dB nominal, 7.5 dB maximum
 (Between Input and either output).
MAXIMUM INPUT POWER: 1 watt average, 1 kilowatt peak
 (Input connector only)

OUTPUT TRACKING (Between Ports):	
Frequency (GHz)	Tracking (maximum dB)
dc - 8	0.15
8 -18	0.20

PHASE TRACKING: ±2° nominal between output ports
POWER COEFFICIENT: < 0.005 dB/dB/watt
TEMPERATURE COEFFICIENT: <0.0004 dB/dB/°C
TEMPERATURE RANGE: -55°C to +85°C
CONSTRUCTION: Nickel plated brass body; stainless steel connectors; gold plated beryllium copper contacts.

MAXIMUM INPUT SWR:

Frequency (GHz)	Maximum SWR
dc - 18	1.30

EQUIVALENT OUTPUT SWR (Port 2 & 3):

Frequency (GHz)	Maximum SWR
dc - 2	1.05
2 - 4	1.07
4 - 8	1.10
8 - 18	1.15

* When used in a leveling or ratio system.

TEST DATA: Insertion Loss, SWR, and Tracking measurements performed across the frequency band. Test data available at additional cost.

CONNECTORS: Type N female connectors per MIL-STD-348 interface dimensions - mate nondestructively with MIL-C-39012 connectors.

WEIGHT: Net 170 g (6 oz)

PHYSICAL DIMENSIONS:

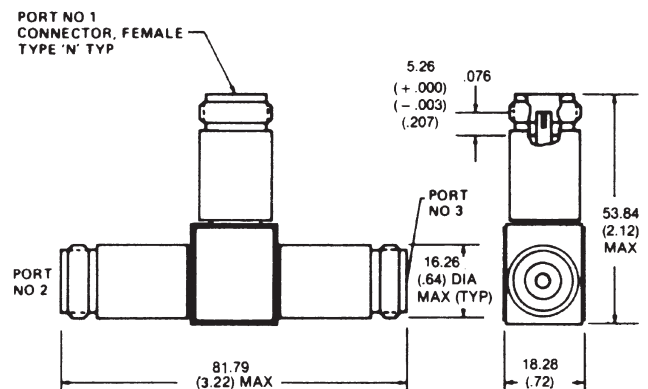

NOTE:

1. All dimensions are given in mm (inches) and are maximum, unless otherwise specified.
2. Unit available with RoHS compliant materials, specify when ordering.

Model 1593 Broadband Resistive Power Splitter (Matching)

dc to 26.5 GHz
1 Watt

Subminiature, 3.5mm Connectors

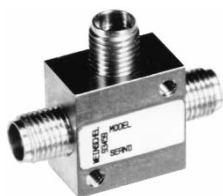

Features

These resistive power splitters are intended for RF and wireless applications in which one of the two outputs is included in a leveling loop or is used as a reference in a ratio system, for the purpose of providing an output signal whose source impedance is essentially matched to 50Ω. Some examples are:

- /// A dual channel insertion loss measuring system (ratio).
- /// A parallel IF substitution insertion loss measuring system (ratio or ALC loop).
- /// A precision power source (ratio or ALC loop).

Specifications

NOMINAL IMPEDANCE: 50 Ω

FREQUENCY RANGE: dc to 26.5 GHz

INSERTION LOSS: 6 dB nominal, 8.5 dB maximum
(Between input and either output)

MAXIMUM INPUT POWER: 1.0 watts CW (Input Connector only)

AMPLITUDE & PHASE TRACKING (Maximum):

Frequency (GHz)	Tracking	
	Amplitude	Phase
dc - 26.5	<0.25 dB	<4°

MAXIMUM INPUT SWR:

Frequency (GHz)	Maximum SWR
dc - 26.5	1.25

EQUIVALENT OUTPUT SWR (Port 2 & 3):

Frequency (GHz)	Maximum SWR
dc - 18	1.25
18 - 26.5	1.35

*When used in a leveling or ratio system.

TEMPERATURE RANGE:

Operating: -55°C to +85°C
Storage: -55°C to +125°C

TEST DATA: Insertion Loss, SWR, and Tracking measurements performed across the frequency band. Test data available at additional cost.

CONNECTORS: Female 3.5mm connectors all ports --mate nondestructively with SMA, 2.92mm and other 3.5mm connectors.

WEIGHT: 25 g (0.9 oz) maximum

PHYSICAL DIMENSIONS:

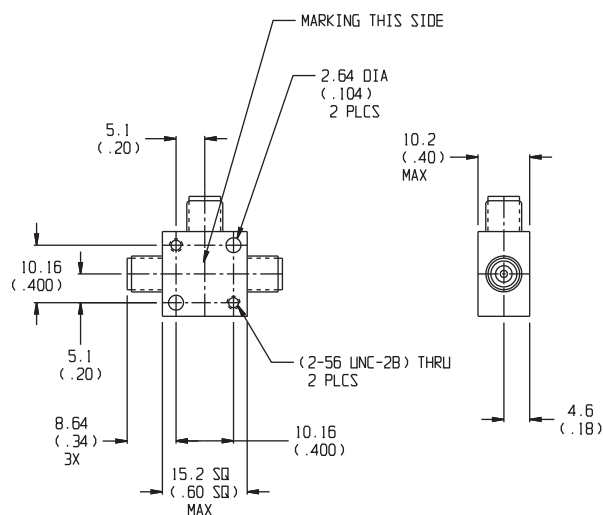

NOTE: All dimensions are given in mm (inches) and are maximum, unless otherwise specified.

Model 1534 Broadband Resistive Power Splitter (Matching)

dc to 40.0 GHz
1 Watt

Subminiature, 2.92mm Connectors

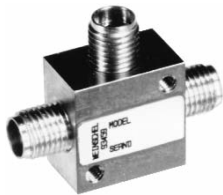

Features

These resistive power splitters are intended for RF and wireless applications in which one of the two outputs is included in a leveling loop or is used as a reference in a ratio system, for the purpose of providing an output signal whose source impedance is essentially matched to 50Ω. Some examples are:

- /// A dual-channel insertion loss measuring system where the resistive power splitter provides a reference and a signal channel for ratio meter.
- /// A parallel IF substitution insertion loss measuring system where the resistive power splitter provides a sampled output for leveling the signal source.
- /// A precision power source where a power meter of known characteristics is used, either by ratio or leveling to provide a calibrated output.

Specifications

NOMINAL IMPEDANCE: 50 Ω

FREQUENCY RANGE: dc to 40.0 GHz

INSERTION LOSS: 6 dB nominal, 8.0 dB maximum to 26.5, 10.5 dB to 40 GHz
(Between input and either output)

MAXIMUM INPUT POWER: 1.0 watt CW (Input Connector only)

AMPLITUDE & PHASE RACKING (Maximum):

Frequency (GHz)	Tracking	
	Amplitude	Phase
dc - 18	<0.20 dB	<2°
18 - 26.5	<0.30 dB	<2°
26.5 - 40	<0.50 dB	<4°

MAXIMUM INPUT SWR:

Frequency (GHz)	Maximum SWR
dc - 18	1.25
18 - 26.5	1.40
26.5 - 40	1.60

EQUIVALENT OUTPUT SWR (Port 2 & 3):

Frequency (GHz)	Maximum SWR
dc - 26.5	1.35
26.5 - 40	160

*When used in a leveling or ration system.

TEMPERATURE RANGE:

Operating: -55°C to +85°C
Storage: -55°C to +125°C

TEST DATA: Insertion Loss, SWR, and Tracking measurements performed across the frequency band. Test data available at additional cost.

CONNECTORS: Female 2.92mm connectors all ports--mate nondestructively with SMA, 2.92mm and other 2.92mm and 3.5mm connectors.

WEIGHT: 25 g (0.9 oz) maximum

PHYSICAL DIMENSIONS:

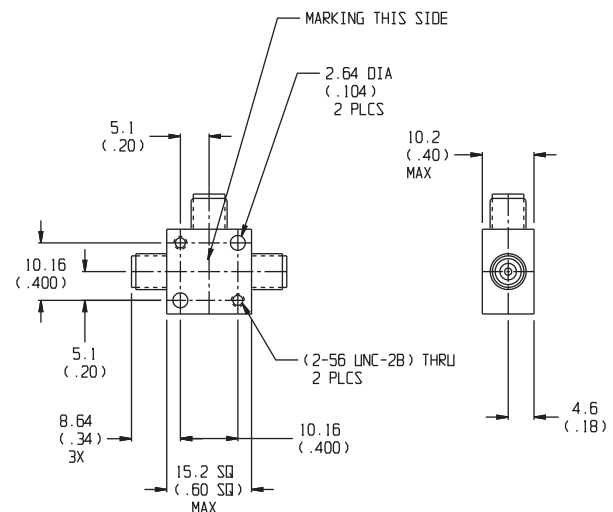

NOTE: All dimensions are given in mm (inches) and are maximum, unless otherwise specified.

Model 1549R Broadband Resistive Power Divider

dc to 4.0 GHz
1 Watt

Low Cost, 2.92mm Connectors

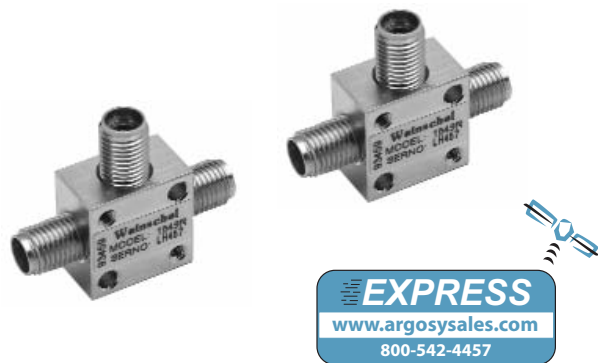

MAXIMUM SWR:

Frequency (GHz)	Output	Input
dc - 4	1.25	1.25

TEMPERATURE RANGE: -55 °C to +125 °C

CONNECTORS: Female 2.92mm connectors all ports--mate nondestructively with other 2.92mm, SMA and 3.5mm connectors.

WEIGHT: 25 g (0.9 oz) maximum

PHYSICAL DIMENSIONS:

Features

- /// Excellent Tracking Between Ports.
- /// Miniature Size and Light Weight.
- /// Wireless Applications - Ideal for use in the wireless communications bands.

Specifications

NOMINAL IMPEDANCE: 50 Ω

FREQUENCY RANGE: dc to 4.0 GHz

INSERTION LOSS: 6 dB nominal, 6.5 dB maximum
(Between input and either output)

MAXIMUM INPUT POWER: 1.0 watt CW (input connector only)

NUMBER OF PORTS: 3, Interchangeable for Input and Output.

AMPLITUDE & PHASE TRACKING (Maximum):

Frequency (GHz)	Tracking	
	Amplitude	Phase
dc - 4.0	<0.2 dB	<4°

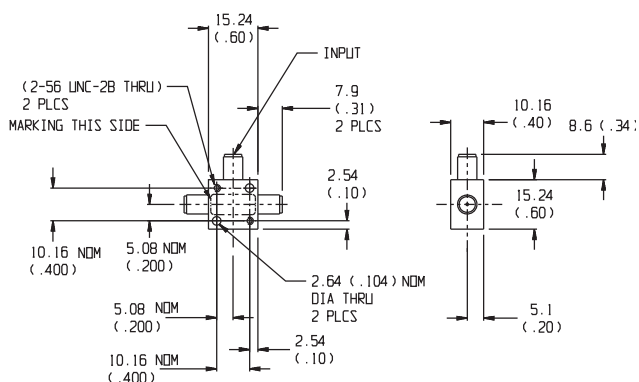

NOTE: All dimensions are given in mm (inches) and are maximum, unless otherwise specified.

Model 1515 & 1515-1 Broadband Resistive Power Divider

dc to 18.0 GHz
1 Watt

SMA Connectors

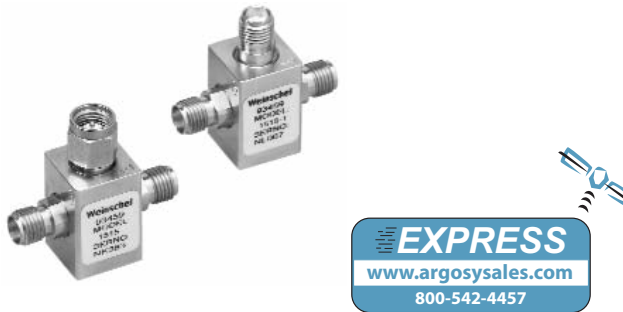

Features

- Miniature Size & Lightweight - High power capability and high ambient temperature operation.
- Close Tracking & Low Frequency Sensitivity - Output power symmetry is excellent across the frequency range. Division is 6 dB from matched ports.
- Test data Data - Insertion loss test data data supplied.

Specifications

NOMINAL IMPEDANCE: 50 Ω
FREQUENCY RANGE: dc to 18.0 GHz
INSERTION LOSS (between input & either output arm):
 6 dB nominal, -0.2 dB, +1.2 to 10 GHz, 1.5 to 18 GHz
MAXIMUM INPUT POWER: 1 watt CW, 1 kilowatt peak
 (5 μsec pulse width, 0.05% duty cycle)
NUMBER OF PORTS: 3, interchangeable for input and output
PHASE TRACKING: 5° maximum between ports (J2 & J3) with input connector (J1).
POWER COEFFICIENT: < 0.005 dB/dB/watt

AMPLITUDE TRACKING-J2 & J3 (Maximum):

Frequency (GHz)	Tracking
dc - 4	0.2 dB
4 - 10	0.4 dB
10 - 18	0.5 dB

MAXIMUM SWR:

Frequency (GHz)	SWR
dc - 10	1.25
10 - 18	1.35

TEMPERATURE COEFFICIENT: < 0.0004 dB/dB/°C
TEMPERATURE RANGE: -55°C to +125°C
CONSTRUCTION: Nickel plated brass body; stainless steel connectors; gold plated beryllium copper contacts.
TEST DATA: Insertion loss data supplied at 50 MHz, 12.0, and 18.0 GHz. Other test data can be provided at additional cost.
CONNECTORS: Model 1515: Male SMA connector port 1 and Female SMA connectors ports 2 and 3.
Model 1515-1: SMA Female connectors all ports--all SMA connectors per MIL-STD-348 interface dimensions - mate nondestructively with MIL-C-39012 connectors.
WEIGHT: Net 30 g (1 oz)
PHYSICAL DIMENSIONS:

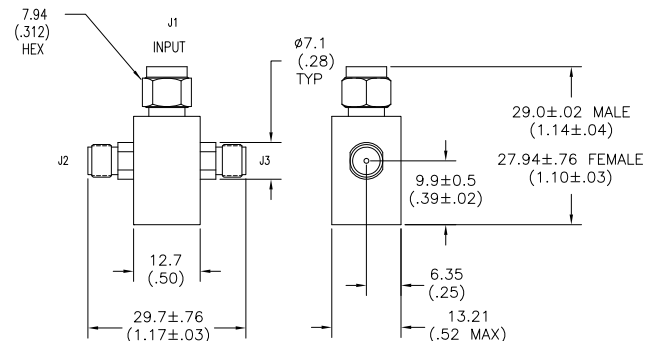

Model No.	Input Connector	Output Connector
1515	SMA Male	SMA Female
1515-1	SMA Female	SMA Female

NOTE:

- All dimensions are given in mm (inches) and are maximum, unless otherwise specified.
- Unit available with RoHS compliant materials, specify when ordering.

Model 1506A Broadband Resistive Power Divider

dc to 18.0 GHz
1 Watt

Type N Connectors



MAXIMUM SWR:	
Frequency (GHz)	SWR
dc - 10	1.25
10 - 18	1.35

Features

- /// **Accurate Division and Low Frequency Sensitivity** - The symmetry of output power between the two arms is excellent across the frequency range.
- /// **High Stability** - Low temperature and power coefficients ensure attenuation stability.
- /// **Test data Data** - Each divider is calibrated at four frequencies, and the data is supplied on a permanently attached test data plate.
- /// **Matched Ports** - Symmetrical 6 dB division permits any port to be used as input.

Specifications

NOMINAL IMPEDANCE: 50 Ω
FREQUENCY RANGE: dc to 18.0 GHz
MAXIMUM INPUT POWER: 1 watt CW, 1 kilowatt peak (5 μsec pulse width, 0.05 % duty cycle)
INSERTION LOSS (between input & one output arm): 6 dB nominal, -0.2, +1.2 dB maximum to 10.0 GHz; +1.5 dB maximum to 18.0 GHz.
NUMBER OF PORTS: 3, interchangeable for input and output
PHASE TRACKING: 5° maximum between ports (J2 & J3) with input connector (J1).

POWER COEFFICIENT: < 0.005 dB/dB/watt
TEMPERATURE COEFFICIENT: < 0.0004 dB/dB/°C
TEMPERATURE RANGE: -55°C to +125°C
CONSTRUCTION: Nickel plated brass body; stainless steel connectors; gold plated beryllium copper contacts.
TEST DATA: Insertion loss data supplied at 50 MHz, 6.0, 12.0, and 18.0 GHz on nameplate only. No paper data supplied. Other test data can be provided at additional cost.
CONNECTORS: Type N connectors per MIL-STD-348 interface dimensions - mate nondestructively with MIL-C-39012 connectors.
WEIGHT: Net 140 g (5 oz)
PHYSICAL DIMENSIONS:

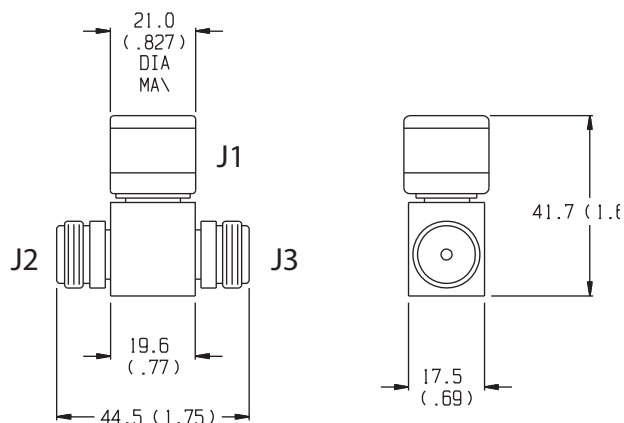

NOTE: All dimensions are given in mm (inches) and are maximum, unless otherwise specified.

AMPLITUDE TRACKING (Maximum):	
Frequency (GHz)	Tracking
dc - 4	0.2 dB
4 - 10	0.4 dB
10 - 18	0.5 dB

Models 1580 & 1580-1 Broadband Resistive Power Dividers

dc to 26.5 GHz
1 Watt

3.5mm Connectors

 **RoHS**

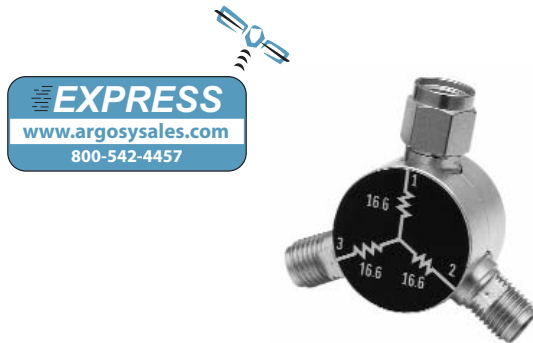

MAXIMUM SWR:

Frequency (GHz)	SWR
dc - 18	1.15
18 - 26.5	1.25

CONSTRUCTION: Gold plated brass body; stainless steel connectors; gold plated beryllium copper contacts.

TEST DATA: Insertion loss, SWR and Tracking data covering 153 frequency points between 50 MHz and 26.5 GHz.

CONNECTORS:

Model 1580: Male 3.5mm connector port 1 and Female 3.5mm connectors ports 2 and 3--all mate nondestructively with SMA, 2.92mm and other 3.5mm connectors.

Model 1580-1: Female 3.5mm connectors all ports--mate nondestructively with SMA, 2.92mm and other 3.5mm connectors.

PHYSICAL DIMENSIONS:

Features

- /// **Miniature Size & Lightweight** - High power capability and high ambient temperature operation.
- /// **Close Tracking & Low Frequency Sensitivity** - Output power symmetry is excellent across the frequency range. Division is 6 dB from matched ports.
- /// **Test Data** - Provided for 153 frequency points

Specifications

NOMINAL IMPEDANCE: 50 Ω

FREQUENCY RANGE: dc to 26.5 GHz

MAXIMUM INPUT POWER: 1 watt CW, 500 watt pulse

INSERTION LOSS (between input & one output arm): 6 dB nominal, 7.5 maximum to 18 GHz and 8.5 maximum to 26.5 GHz.

NUMBER OF PORTS: 3, interchangeable for input and output

TRACKING (Maximum):

Frequency (GHz)	Amplitude	Phase
dc - 26.5	0.20 dB	8°

POWER COEFFICIENT: < 0.005 dB/dB/watt

TEMPERATURE COEFFICIENT: < 0.0004 dB/dB/°C

TEMPERATURE RANGE: -55°C to +125°C

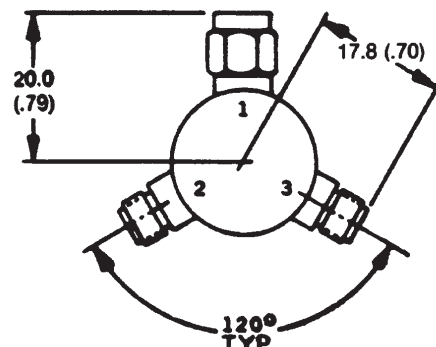
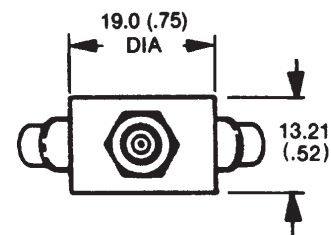

NOTE:

1. All dimensions are given in mm (inches) and are maximum, unless otherwise specified.
2. Unit available with RoHS compliant materials, specify when ordering.

Model 1575 Broadband Resistive Power Divider

dc to 40.0 GHz
1.0 Watt

Subminiature, 2.92mm Connectors

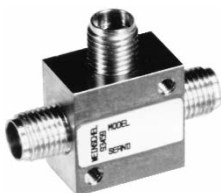

Features

This three resistor Power Divider is designed for applications where an RF and Microwave signal must be accurately divided or combined.

- /// **Miniature Size and Lightweight** - High power capability and high ambient temperature operation.
- /// **Close Tracking and Low Frequency Sensitivity** - Output power symmetry is excellent across the frequency range. Division is 6 dB from matched ports.

Specifications

NOMINAL IMPEDANCE: 50 Ω

FREQUENCY RANGE: dc to 40.0 GHz

INSERTION LOSS (Between input and either output):
6 dB nominal, 8.5 dB maximum

MAXIMUM INPUT POWER: 1.0 watts CW, 1 kilowatt peak, 5 μ sec pulse width

NUMBER OF PORTS: 3, interchangeable for input and output

AMPLITUDE & PHASE TRACKING (Maximum):

Frequency (GHz)	Tracking	
	Amplitude	Phase
dc - 19	<0.25 dB	2°
19 - 40	<0.50 dB	5°

MAXIMUM SWR:

Frequency (GHz)	SWR
dc - 19	1.40
19 - 40	1.70

TEMPERATURE RANGE: -55°C to +85°C

TEST DATA: Insertion Loss, SWR, and Tracking measurements performed across the frequency band. Test data available at additional cost.

CONNECTORS: Female 2.92mm connectors all ports--mate nondestructively with SMA, 2.92mm and other 2.92mm and 3.5mm connectors.

WEIGHT: 25 g (0.9 oz) maximum

PHYSICAL DIMENSIONS:

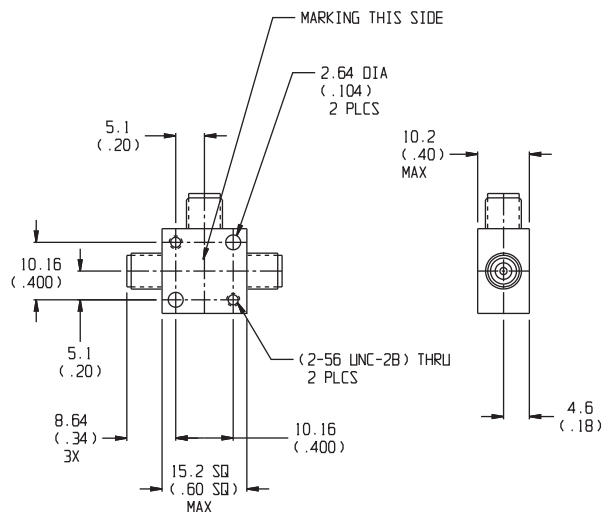

NOTE: All dimensions are given in mm (inches) and are maximum, unless otherwise specified.

Model 1550A Model 1594 4-WAY Resistive Power Dividers

Subminiature, SMA/3.5mm Connectors

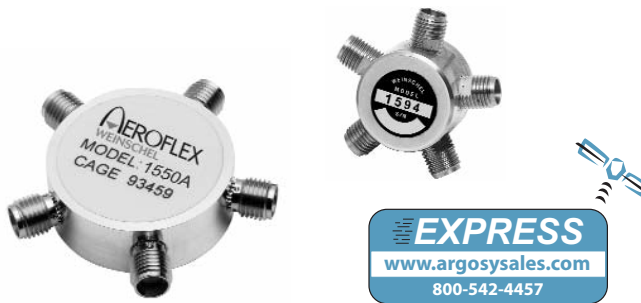

MAXIMUM SWR:

Model No.	SWR
1550A	1.25
1594	1.30

WEIGHT: 1550A: 28 g (1.0 oz) maximum
1594: 30 g (1.05 oz) maximum

PHYSICAL DIMENSIONS:

Model 1550A:

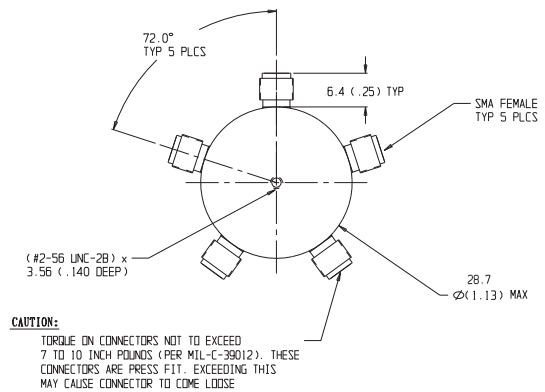
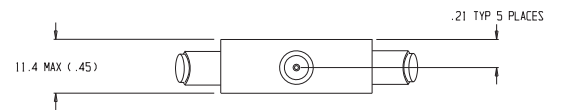

Model 1594:

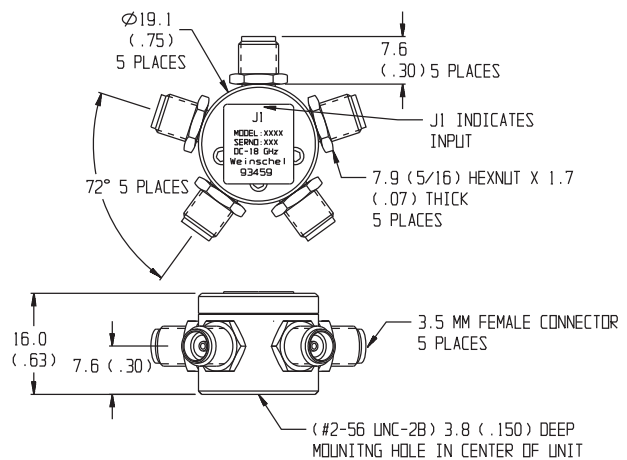

NOTE:

- All dimensions are given in mm (inches) and are maximum, unless otherwise specified.
- Unit available with RoHS compliant materials, specify when ordering.

Features

- /// **Broadband Performance.**
- /// **Excellent Tracking Between Ports.**
- /// **Miniature Size and Light Weight.**
- /// **Wireless Applications** - Model 1550A is specifically designed for use in the wireless communications bands.

Specifications

NOMINAL IMPEDANCE: 50 Ω

FREQUENCY RANGE: 1550A: dc to 3.0 GHz (usable to 5 GHz)
1594: dc to 18.0 GHz

INSERTION LOSS*:

Model 1550A: 12 dB nominal, 13.5 dB maximum
Model 1594: 12 dB nominal, 14.5 dB maximum
* input port to any output port with all other terminated.

MAXIMUM INPUT POWER: 1550A: 1 watt CW
1594: 2 watts CW

AMPLITUDE & PHASE TRACKING (Maximum):

Model No.	Frequency (GHz)	Tracking*	
		Amplitude	Phase
1550A	dc - 3	±0.5 dB	±10°
1594	dc - 12	<2.0 dB	<30°
	12 - 18	<2.5 dB	<50°

*Between output ports.

NUMBER OF PORTS: 1 input and 4 outputs

TEMPERATURE RANGE: -55°C to +100°C

CONNECTORS: Model 1550A: SMA female connectors all ports--mate nondestructively with other SMA, 2.92mm and 3.5mm connectors.

Model 1594: 3.5mm female connectors all ports--mate non-destructively with other SMA, 2.92mm and 3.5mm connectors.