

Standard Products

VRG8687/VRG8688

Dual Voltage Regulator, 3.0 Amp, Positive Low Dropout (LDO), Adjustable Radiation Tolerant

www.aeroflex.com/voltreg

October 24, 2011



AEROFLEX
A passion for performance.

FEATURES

- Manufactured using  Linear Technology Corporation® Space Qualified RH1084 die
- Radiation performance
 - Total dose ≥ 100 krad (Si),
 - Dose rate = 50 - 300 rads(Si)/s
- Two-Independent voltage regulators
- Thermal shutdown
- Output voltage adjustable: 1.25V to 23V
- Dropout voltage: 1.80V at 3.0Amps
- 3-Terminal
- Output current: 3.0Amps
- Voltage reference: 1.25V +2%, -3.2%
- Load regulation: 0.35% max
- Line regulation: 0.25% max
- Ripple rejection: >60dB
- Packaging – Hermetic metal
 - Thru-hole or Surface mount
 - 8 Leads, .755"L x .415"W x .200"Ht
 - Power package
 - Weight - 6 gm max
- Designed for aerospace and high reliability space applications
- Aeroflex Plainview's Radiation Hardness Assurance Plan is DLA Certified to MIL-PRF-38534, Appendix G.

DESCRIPTION

The Aeroflex Plainview VRG8687/8688 consists of two Positive Adjustable (RH1084) LDO voltage regulators each capable of supplying 3.0Amps over the output voltage range as defined under recommended operating conditions. The VRG8687/8688 offers excellent line and load regulation specifications and ripple rejection. There is full electrical isolation between the regulators and each regulator to the package.

Dropout ($V_{IN} - V_{OUT}$) decreases at lower load currents for both regulators.

The VRG8687/8688 serves a wide variety of applications including SCSI-2 Active Terminator, High Efficiency Linear Regulators, Post Regulators for Switching Supplies, Constant Current Regulators, Battery Chargers and Microprocessor Supply.

The VRG8687/8688 has been specifically designed to meet exposure to radiation environments. The VRG8687 is configured for a Thru-Hole 8 lead metal power package and the VRG8688 is configured for a Surface Mount 8 lead metal power package. It is guaranteed operational from -55°C to $+125^{\circ}\text{C}$. Available screened in accordance with MIL-PRF-38534, the VRG8687/8688 is ideal for demanding military and space applications.

For detailed performance characteristic curves, applications information and typical applications see the latest  Linear Technology Corporation® data sheets for their RH/LT1084, which is available on-line at www.linear.com.

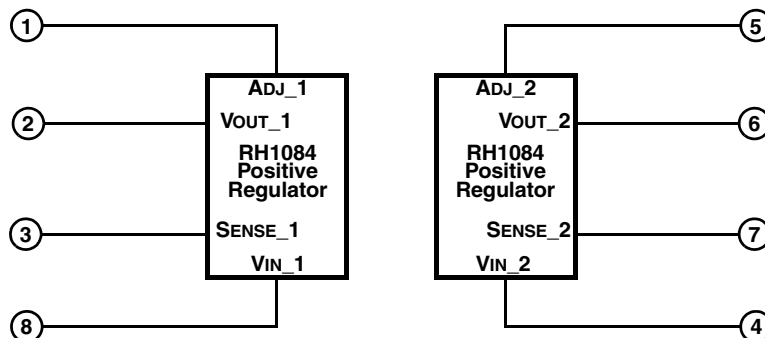

FIGURE 1 – BLOCK DIAGRAM / SCHEMATIC

ABSOLUTE MAXIMUM RATINGS

Parameter	Range	Units
Input Voltage	+25	VDC
Lead temperature (soldering 10 Sec)	300	°C
Input Output Differential	25	VDC
Load Current, maximum	6.0	A
Output Voltage	+25	VDC
ESD (MIL-STD-883, M3015, Class 2)	2000 to 3999	V
Operating Junction Temperature Range	-55 to +150	°C
Storage Temperature Range	-65 to +150	°C
Thermal Resistance, Junction to case Θ_{JC}	5	°C/W

NOTICE: Stresses above those listed under "Absolute Maximums Rating" may cause permanent damage to the device. These are stress rating only; functional operation beyond the "Operation Conditions" is not recommended and extended exposure beyond the "Operation Conditions" may effect device reliability.

RECOMMENDED OPERATING CONDITIONS

Parameter	Range	Units
Output Voltage Range	1.25 to 23	VDC
Input Output Differential ^{3/}	1.8 to 24	VDC
Case Operating Temperature Range	-55 to +125	°C

ELECTRICAL PERFORMANCE CHARACTERISTICS ^{1/}

UNLESS OTHERWISE SPECIFIED: $-55^{\circ}\text{C} \leq T_C \leq +125^{\circ}\text{C}$

Parameter	Symbol	Conditions ($P \leq P_{MAX}$)	Min	Max	Units
Reference Voltage ^{3/} , ^{2/}	VREF	$1.5\text{V} \leq (V_{IN} - V_{OUT}) \leq 15\text{V}$, $10\text{mA} \leq I_{OUT} \leq 3.0\text{A}$	1.210	1.275	V
Line Regulation ^{3/} , ^{2/}	$\frac{\Delta V_{OUT}}{\Delta V_{IN}}$	$I_{LOAD} = 10\text{mA}$, $1.5\text{V} \leq (V_{IN} - V_{OUT}) \leq 15\text{V}$	-	0.25	%
Load Regulation ^{3/} , ^{2/}	$\frac{\Delta V_{OUT}}{\Delta I_{OUT}}$	$10\text{mA} \leq I_{OUT} \leq 3.0\text{A}$, $(V_{IN} - V_{OUT}) = 3\text{V}$	-	0.35	%
Dropout Voltage ^{4/} , ^{2/}	VDROP	$\Delta V_{REF} = 1\%$, $I_{OUT} = 3.0\text{A}$	-	1.8	V
Adjust Pin Current ^{2/}	-		-	120	μA
Adjust Pin Current Change ^{2/}	-	$10\text{mA} \leq I_{OUT} \leq 3.0\text{A}$, $1.5\text{V} \leq (V_{IN} - V_{OUT}) \leq 15\text{V}$	-	5	μA
Minimum Load Current ^{5/} , ^{2/}	IMIN	$(V_{IN} - V_{OUT}) = 25\text{V}$	-	10	mA
Current Limit ^{2/}	ICL	$(V_{IN} - V_{OUT}) = 5\text{V}$	5.25	-	A
Ripple Rejection ^{3/}	-	$I_{OUT} = 3.0\text{A}$, $(V_{IN} - V_{OUT}) = 3\text{V}$, $f = 120\text{Hz}$, $C_{ADJ} = C_{OUT} = 25\mu\text{F}$	60	-	dB
Thermal Regulation	-	30ms pulse, $T_C = +25^{\circ}\text{C}$	-	0.015	%/W
VREF Long-Term Stability ^{5/}	-	Burn In: $T_C = +125^{\circ}\text{C}$ @ 1000hrs minimum, tested @ 25°C	-	1.0	%

Notes:

^{1/} The manufacturer's output current rating for the RH1084MK positive regulator integrated circuit is 5.0 Amps. For Compliance with the Current Density specification of MIL-STD-883 Rev. C, the electrical performance characteristics are specified at an output current of 3.0 Amps.

^{2/} Specification derated to reflect total dose exposure to 100krads (Si) at $+25^{\circ}\text{C}$.

^{3/} Line and load regulation are guaranteed up to the maximum power dissipation of 15W per device. Power dissipation is determined by the input/output differential voltage and the output current. Guaranteed maximum power dissipation will not be available over the full input/output voltage range.

^{4/} Dropout voltage is specified over the full output current range of the device.

^{5/} Not tested. Shall be guaranteed by design, characterization, or correlation to other tested parameters.

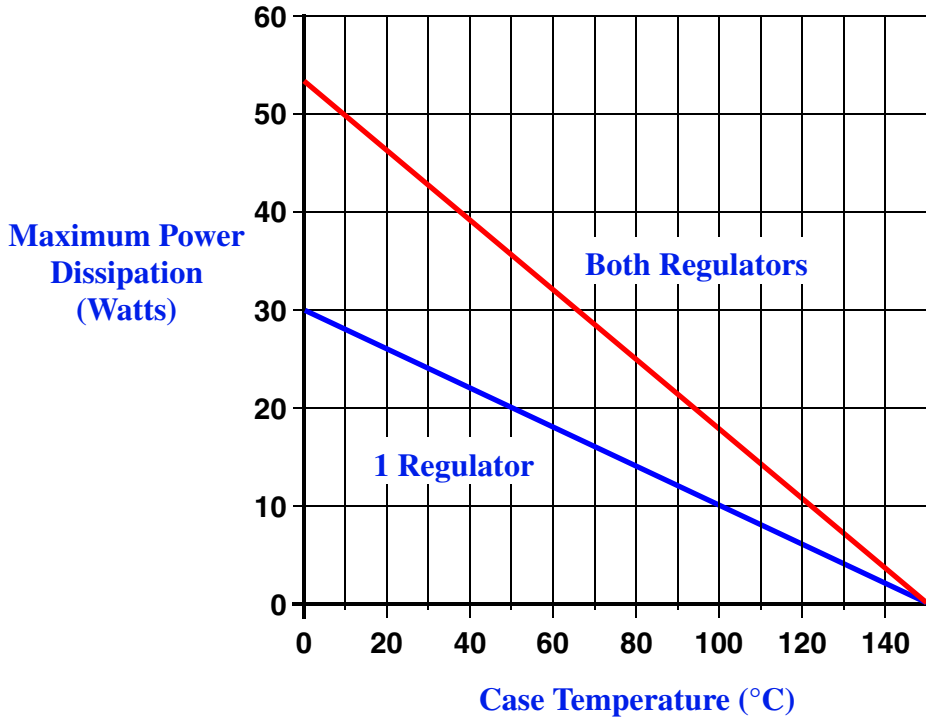

FIGURE 2 – MAXIMUM POWER vs CASE TEMPERATURE

The maximum Power dissipation is limited by the thermal shutdown function of each regulator chip in the VG8687/8688. The graph above represents the achievable power before the chip shuts down. The first line in the graph represents the maximum power dissipation of the VG8687/8688 with one regulator on (the other off) and the other line represents both regulators on dissipating equal power. If both regulators are on and one regulator is dissipating more power than the other, the maximum power dissipation of the VG8687/8688 will fall between the two lines. This graph is based on the maximum junction temperature of 150°C and a thermal resistance (θ_{JC}) of 5°C/W.

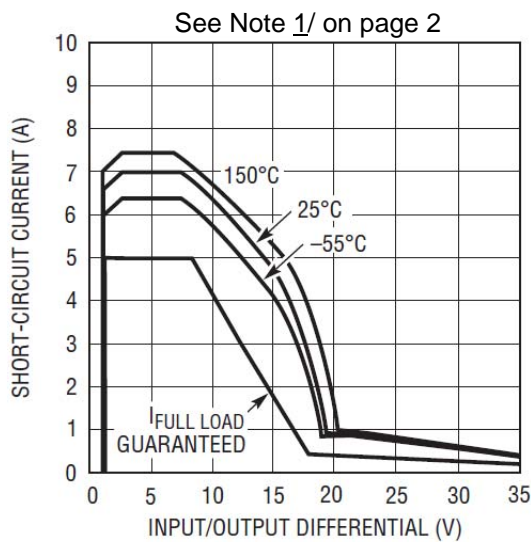

FIGURE 3 – RH1084 SHORT CIRCUIT CURRENT

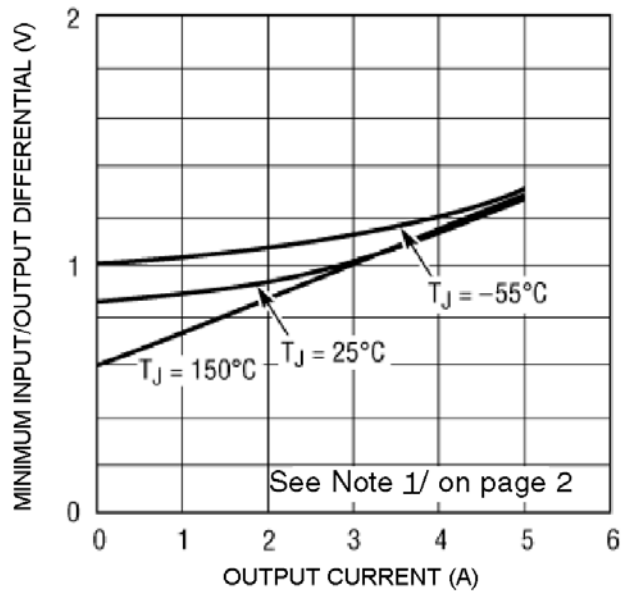

FIGURE 4 – RH1084 DROPOUT VOLTAGE TYPICAL CURVE

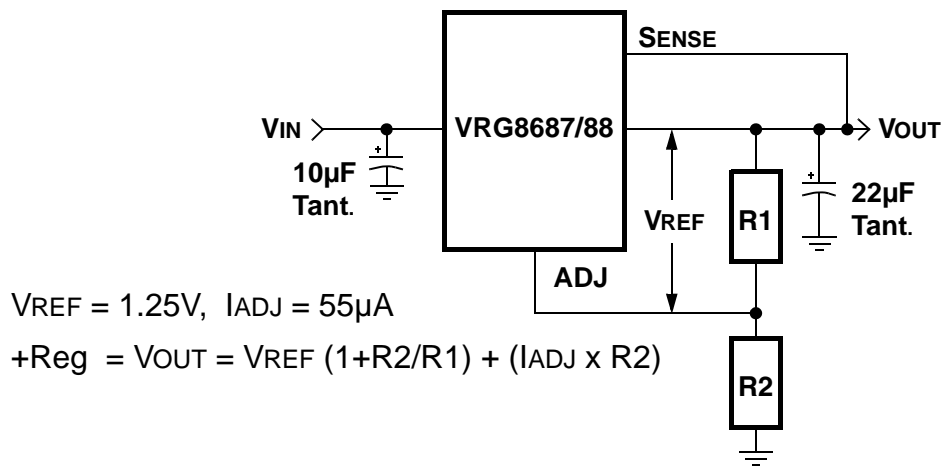
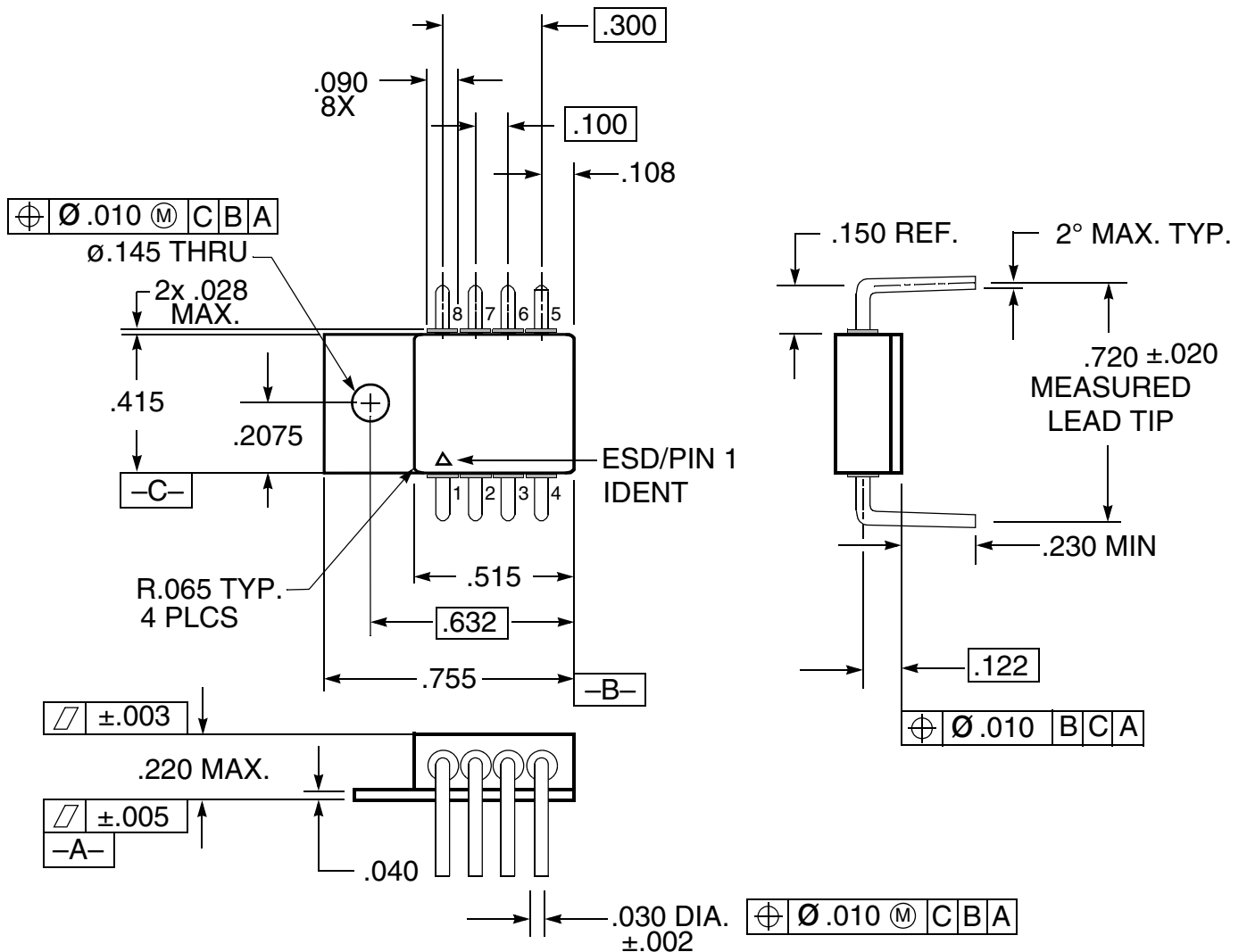

FIGURE 5 – BASIC RH1084 ADJUSTABLE REGULATOR APPLICATION

TABLE I – PIN NUMBERS vs FUNCTION

PIN	FUNCTION
1	ADJ_1
2	VOUT_1
3	SENSE_1
4	VIN_2
5	ADJ_2
6	VOUT_2
7	SENSE_2
8	VIN_1



Notes:

1. Dimension Tolerance: $\pm .005$ inches
2. Package contains BeO substrate
3. Case electrically isolated

FIGURE 5 – VRG8687 PACKAGE OUTLINE — THRU-HOLE POWER PACKAGE

ORDERING INFORMATION

MODEL	DLA SMD #	SCREENING	PACKAGE
VRG8687-7	-	Commercial Flow, +25°C testing only	8 Lead Thru-Hole Power Pkg
VRG8687-S	-	Military Temperature, -55°C to +125°C Screened in accordance with the individual Test Methods of MIL-STD-883 for Space Applications	
VRG8687-201-1S	5962-1021302KUC	DLA SMD Pending	
VRG8687-201-2S	5962-1021302KUA		
VRG8688-7	-	Commercial Flow, +25°C testing only	8 Lead Surface Mount Power Pkg
VRG8688-S	-	Military Temperature, -55°C to +125°C Screened in accordance with the individual Test Methods of MIL-STD-883 for Space Applications	
VRG8688-201-1S	5962-1021302KZC	DLA SMD Pending	
VRG8688-201-2S	5962-1021302KZA		

EXPORT CONTROL:

This product is controlled for export under the International Traffic in Arms Regulations (ITAR). A license from the U.S. Department of State is required prior to the export of this product from the United States.

EXPORT WARNING:

Aeroflex's military and space products are controlled for export under the International Traffic in Arms Regulations (ITAR) and may not be sold or proposed or offered for sale to certain countries. (See ITAR 126.1 for complete information.)

PLAINVIEW, NEW YORK

Toll Free: 800-THE-1553
Fax: 516-694-6715

INTERNATIONAL

Tel: 805-778-9229
Fax: 805-778-1980

NORTHEAST

Tel: 603-888-3975
Fax: 603-888-4585

SE AND MID-ATLANTIC

Tel: 321-951-4164
Fax: 321-951-4254

WEST COAST

Tel: 949-362-2260
Fax: 949-362-2266

CENTRAL

Tel: 719-594-8017
Fax: 719-594-8468

www.aeroflex.com info-ams@aeroflex.com



Aeroflex Microelectronic Solutions reserves the right to change at any time without notice the specifications, design, function, or form of its products described herein. All parameters must be validated for each customer's application by engineering. No liability is assumed as a result of use of this product. No patent licenses are implied.

 and the Linear Technology logo are registered trademarks and RH1084 are a copyright of Linear Technology Corporation.



Our passion for performance is defined by three attributes represented by these three icons: solution-minded, performance-driven and customer-focused