

UT54ACS00/UT54ACTS00

Radiation-Hardened Quadruple 2-Input NAND Gates

FEATURES

- 1.2μ radiation-hardened CMOS
 - Latchup immune
- High speed
- Low power consumption
- Single 5 volt supply
- Available QML Q or V processes
- Flexible package
 - 14-pin DIP
 - 14-lead flatpack

DESCRIPTION

The UT54ACS00 and the UT54ACTS00 are quadruple, two-input NAND gates. The circuits perform the Boolean functions $Y = \overline{A \cdot B}$ or $Y = \overline{A} + \overline{B}$ in positive logic.

The devices are characterized over full military temperature range of -55°C to +125°C.

FUNCTION TABLE

INPUTS		OUTPUT
A	B	Y
H	H	L
L	X	H
X	L	H

LOGIC SYMBOL

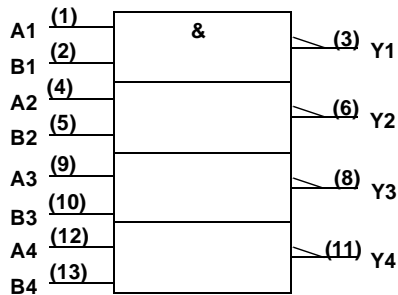

Note:

1. Logic symbol in accordance with ANSI/IEEE standard 91-1984 and IEC Publication 617-12.

PINOUTS

14-Pin DIP Top View

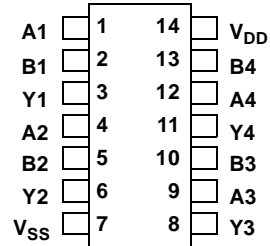

14-Lead Flatpack Top View

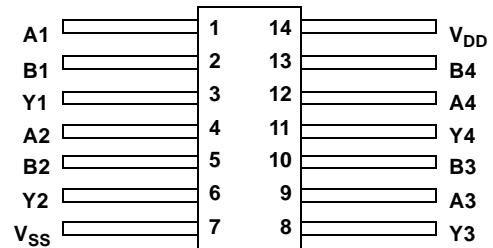

LOGIC DIAGRAM

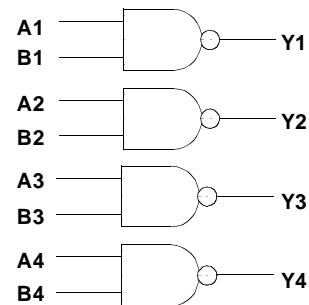

RADIATION HARDNESS SPECIFICATIONS ¹

PARAMETER	LIMIT	UNITS
Total Dose	1.0E6	rads(Si)
SEU Threshold ²	80	MeV-cm ² /mg
SEL Threshold	120	MeV-cm ² /mg
Neutron Fluence	1.0E14	n/cm ²

Notes:

1. Logic will not latchup during radiation exposure within the limits defined in the table.
2. Device storage elements are immune to SEU affects.

ABSOLUTE MAXIMUM RATINGS

SYMBOL	PARAMETER	LIMIT	UNITS
V _{DD}	Supply voltage	-0.3 to 7.0	V
V _{I/O}	Voltage any pin	-.3 to V _{DD} +.3	V
T _{STG}	Storage Temperature range	-65 to +150	°C
T _J	Maximum junction temperature	+175	°C
T _{LS}	Lead temperature (soldering 5 seconds)	+300	°C
Θ _{JC}	Thermal resistance junction to case	20	°C/W
I _I	DC input current	±10	mA
P _D	Maximum power dissipation	1	W

Note:

1. Stresses outside the listed absolute maximum ratings may cause permanent damage to the device. This is a stress rating only, functional operation of the device at these or any other conditions beyond limits indicated in the operational sections is not recommended. Exposure to absolute maximum rating conditions for extended periods may affect device reliability.

RECOMMENDED OPERATING CONDITIONS

SYMBOL	PARAMETER	LIMIT	UNITS
V _{DD}	Supply voltage	4.5 to 5.5	V
V _{IN}	Input voltage any pin	0 to V _{DD}	V
T _C	Temperature range	-55 to + 125	°C

DC ELECTRICAL CHARACTERISTICS ⁷

($V_{DD} = 5.0V \pm 10\%$; $V_{SS} = 0V$ ⁶, $-55^{\circ}C < T_C < +125^{\circ}C$)

SYMBOL	PARAMETER	CONDITION	MIN	MAX	UNIT
V_{IL}	Low-level input voltage ¹ ACTS ACS			0.8 .3 V_{DD}	V
V_{IH}	High-level input voltage ¹ ACTS ACS		.5 V_{DD} .7 V_{DD}		V
I_{IN}	Input leakage current ACTS/ACS	$V_{IN} = V_{DD}$ or V_{SS}	-1	1	μA
V_{OL}	Low-level output voltage ³ ACTS ACS	$I_{OL} = 8.0mA$ $I_{OL} = 100\mu A$		0.40 0.25	V
V_{OH}	High-level output voltage ³ ACTS ACS	$I_{OH} = -8.0mA$ $I_{OH} = -100\mu A$.7 V_{DD} $V_{DD} - 0.25$		V
I_{OS}	Short-circuit output current ^{2,4} ACTS/ACS	$V_O = V_{DD}$ and V_{SS}	-200	200	mA
I_{OL}	Output current ¹⁰ (Sink)	$V_{IN} = V_{DD}$ or V_{SS} $V_{OL} = 0.4V$	8		mA
I_{OH}	Output current ¹⁰ (Source)	$V_{IN} = V_{DD}$ or V_{SS} $V_{OH} = V_{DD} - 0.4V$	-8		mA
P_{total}	Power dissipation ^{2, 8, 9}	$C_L = 50pF$		1.8	mW/ MHz
I_{DDQ}	Quiescent Supply Current	$V_{DD} = 5.5V$		10	μA
ΔI_{DDQ}	Quiescent Supply Current Delta ACTS	For input under test $V_{IN} = V_{DD} - 2.1V$ For all other inputs $V_{IN} = V_{DD}$ or V_{SS} $V_{DD} = 5.5V$		1.6	mA
C_{IN}	Input capacitance ⁵	$f = 1MHz @ 0V$		15	pF
C_{OUT}	Output capacitance ⁵	$f = 1MHz @ 0V$		15	pF

Notes:

- Functional tests are conducted in accordance with MIL-STD-883 with the following input test conditions: $V_{IH} = V_{IH(min)} + 20\%$, $- 0\%$; $V_{IL} = V_{IL(max)} + 0\%$, $- 50\%$, as specified herein, for TTL, CMOS, or Schmitt compatible inputs. Devices may be tested using any input voltage within the above specified range, but are guaranteed to $V_{IH(min)}$ and $V_{IL(max)}$.
- Supplied as a design limit but not guaranteed or tested.
- Per MIL-PRF-38535, for current density $\leq 5.0E5$ amps/cm², the maximum product of load capacitance (per output buffer) times frequency should not exceed 3,765 pF/MHz.
- Not more than one output may be shorted at a time for maximum duration of one second.
- Capacitance measured for initial qualification and when design changes may affect the value. Capacitance is measured between the designated terminal and V_{SS} at frequency of 1MHz and a signal amplitude of 50mV rms maximum.
- Maximum allowable relative shift equals 50mV.
- All specifications valid for radiation dose $\leq 1E6$ rads(Si).
- Power does not include power contribution of any TTL output sink current.
- Power dissipation specified per switching output.
- This value is guaranteed based on characterization data, but not tested.

AC ELECTRICAL CHARACTERISTICS ²

($V_{DD} = 5.0V \pm 10\%$; $V_{SS} = 0V$ ¹, $-55^{\circ}C < T_C < +125^{\circ}C$)

SYMBOL	PARAMETER	MINIMUM	MAXIMUM	UNIT
t_{PHL}	Input to Yn	1	14	ns
t_{PLH}	Input to Yn	1	11	ns

Notes:

- Maximum allowable relative shift equals 50mV.
- All specifications valid for radiation dose $\leq 1E6$ rads(Si).

UT54ACS02/UT54ACTS02

Radiation-Hardened Quadruple 2-Input NOR Gates

FEATURES

- 1.2μ radiation-hardened CMOS
 - Latchup immune
- High speed
- Low power consumption
- Single 5 volt supply
- Available QML Q or V processes
- Flexible package
 - 14-pin DIP
 - 14-lead flatpack

DESCRIPTION

The UT54ACS02 and the UT54ACTS02 are quadruple, two-input NOR gates. The circuits perform the Boolean functions $Y = A + B$ or $Y = \overline{A} \cdot \overline{B}$ in positive logic.

The devices are characterized over full military temperature range of -55°C to +125°C.

FUNCTION TABLE

INPUTS		OUTPUT
A	B	Y
H	X	L
X	H	L
L	L	H

LOGIC SYMBOL

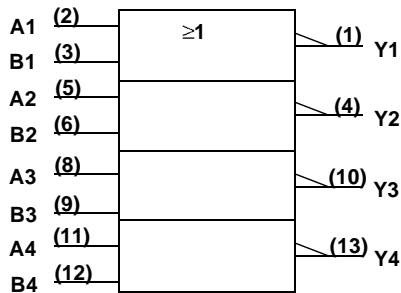

Note:

1. Logic symbol in accordance with ANSI/IEEE standard 91-1984 and IEC Publication 617-12.

PINOUTS

14-Pin DIP Top View

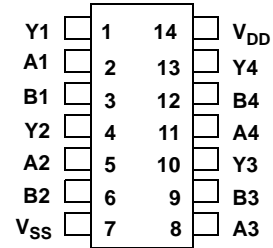

14-Lead Flatpack Top View

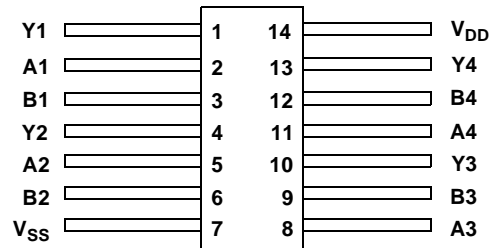

LOGIC DIAGRAM

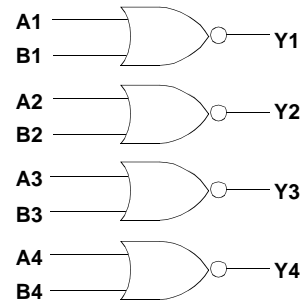

RADIATION HARDNESS SPECIFICATIONS ¹

PARAMETER	LIMIT	UNITS
Total Dose	1.0E6	rads(Si)
SEU Threshold ²	80	MeV-cm ² /mg
SEL Threshold	120	MeV-cm ² /mg
Neutron Fluence	1.0E14	n/cm ²

Notes:

1. Logic will not latchup during radiation exposure within the limits defined in the table.
2. Device storage elements are immune to SEU affects.

ABSOLUTE MAXIMUM RATINGS

SYMBOL	PARAMETER	LIMIT	UNITS
V _{DD}	Supply voltage	-0.3 to 7.0	V
V _{I/O}	Voltage any pin	-.3 to V _{DD} +.3	V
T _{STG}	Storage Temperature range	-65 to +150	°C
T _J	Maximum junction temperature	+175	°C
T _{LS}	Lead temperature (soldering 5 seconds)	+300	°C
Θ _{JC}	Thermal resistance junction to case	20	°C/W
I _I	DC input current	±10	mA
P _D	Maximum power dissipation	1	W

Note:

1. Stresses outside the listed absolute maximum ratings may cause permanent damage to the device. This is a stress rating only, functional operation of the device at these or any other conditions beyond limits indicated in the operational sections is not recommended. Exposure to absolute maximum rating conditions for extended periods may affect device reliability.

RECOMMENDED OPERATING CONDITIONS

SYMBOL	PARAMETER	LIMIT	UNITS
V _{DD}	Supply voltage	4.5 to 5.5	V
V _{IN}	Input voltage any pin	0 to V _{DD}	V
T _C	Temperature range	-55 to + 125	°C

DC ELECTRICAL CHARACTERISTICS ⁷

($V_{DD} = 5.0V \pm 10\%$; $V_{SS} = 0V$ ⁶, $-55^{\circ}C < T_C < +125^{\circ}C$)

SYMBOL	PARAMETER	CONDITION	MIN	MAX	UNIT
V_{IL}	Low-level input voltage ¹ ACTS ACS			0.8 .3 V_{DD}	V
V_{IH}	High-level input voltage ¹ ACTS ACS		.5 V_{DD} .7 V_{DD}		V
I_{IN}	Input leakage current ACTS/ACS	$V_{IN} = V_{DD}$ or V_{SS}	-1	1	μA
V_{OL}	Low-level output voltage ³ ACTS ACS	$I_{OL} = 8.0mA$ $I_{OL} = 100\mu A$		0.40 0.25	V
V_{OH}	High-level output voltage ³ ACTS ACS	$I_{OH} = -8.0mA$ $I_{OH} = -100\mu A$.7 V_{DD} $V_{DD} - 0.25$		V
I_{OS}	Short-circuit output current ^{2,4} ACTS/ACS	$V_O = V_{DD}$ and V_{SS}	-200	200	mA
I_{OL}	Output current ¹⁰ (Sink)	$V_{IN} = V_{DD}$ or V_{SS} $V_{OL} = 0.4V$	8		mA
I_{OH}	Output current ¹⁰ (Source)	$V_{IN} = V_{DD}$ or V_{SS} $V_{OH} = V_{DD} - 0.4V$	-8		mA
P_{total}	Power dissipation ^{2, 8, ,9}	$C_L = 50pF$		1.8	mW/ MHz
I_{DDQ}	Quiescent Supply Current	$V_{DD} = 5.5V$		10	μA
ΔI_{DDQ}	Quiescent Supply Current Delta ACTS	For input under test $V_{IN} = V_{DD} - 2.1V$ For all other inputs $V_{IN} = V_{DD}$ or V_{SS} $V_{DD} = 5.5V$		1.6	mA
C_{IN}	Input capacitance ⁵	$f = 1MHz @ 0V$		15	pF
C_{OUT}	Output capacitance ⁵	$f = 1MHz @ 0V$		15	pF

Notes:

1. Functional tests are conducted in accordance with MIL-STD-883 with the following input test conditions: $V_{IH} = V_{IH(min)} + 20\%$, $- 0\%$; $V_{IL} = V_{IL(max)} + 0\%$, $- 50\%$, as specified herein, for TTL, CMOS, or Schmitt compatible inputs. Devices may be tested using any input voltage within the above specified range, but are guaranteed to $V_{IH(min)}$ and $V_{IL(max)}$.
2. Supplied as a design limit but not guaranteed or tested.
3. Per MIL-PRF-38535, for current density $\leq 5.0E5$ amps/cm², the maximum product of load capacitance (per output buffer) times frequency should not exceed 3,765 pF/MHz.
4. Not more than one output may be shorted at a time for maximum duration of one second.
5. Capacitance measured for initial qualification and when design changes may affect the value. Capacitance is measured between the designated terminal and V_{SS} at frequency of 1MHz and a signal amplitude of 50mV rms maximum.
6. Maximum allowable relative shift equals 50mV.
7. All specifications valid for radiation dose $\leq 1E6$ rads(Si).
8. Power does not include power contribution of any TTL output sink current.
9. Power dissipation specified per switching output.
10. This value is guaranteed based on characterization data, but not tested.

AC ELECTRICAL CHARACTERISTICS ²

($V_{DD} = 5.0V \pm 10\%$; $V_{SS} = 0V$ ¹, $-55^{\circ}C < T_C < +125^{\circ}C$)

SYMBOL	PARAMETER	MINIMUM	MAXIMUM	UNIT
t _{PHL}	Input to Yn	1	13	ns
t _{PLH}	Input to Yn	1	11	ns

Notes:

1. Maximum allowable relative shift equals 50mV.
2. All specifications valid for radiation dose $\leq 1E6$ rads(Si).

UT54ACS04/UT54ACTS04

Radiation-Hardened Hex Inverters

FEATURES

- 1.2μ radiation-hardened CMOS
 - Latchup immune
- High speed
- Low power consumption
- Single 5 volt supply
- Available QML Q or V processes
- Flexible package
 - 14-pin DIP
 - 14-lead flatpack

DESCRIPTION

The UT54ACS04 and the UT54ACTS04 are hex inverters. The circuits perform the Boolean function $Y = \bar{A}$.

The devices are characterized over full military temperature range of -55°C to +125°C.

FUNCTION TABLE

INPUT	OUTPUT
A	Y
H	L
L	H

LOGIC SYMBOL

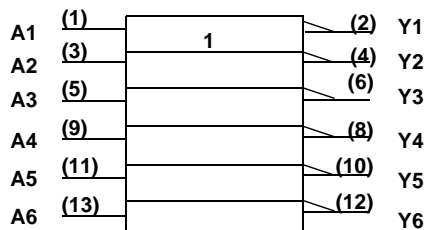

Note:

1. Logic symbol in accordance with ANSI/IEEE standard 91-1984 and IEC Publication 617-12.

PINOUTS

14-Pin DIP Top View

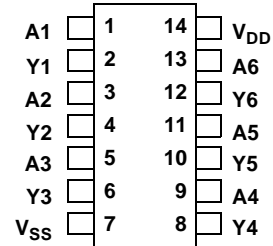

14-Lead Flatpack Top View

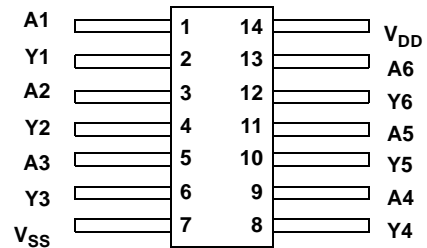

LOGIC DIAGRAM

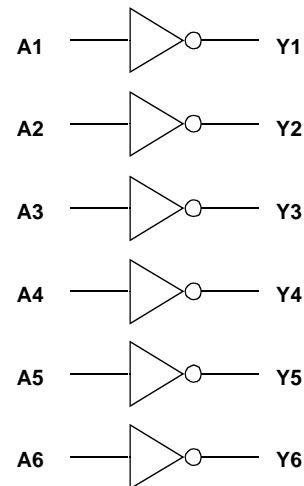

RADIATION HARDNESS SPECIFICATIONS ¹

PARAMETER	LIMIT	UNITS
Total Dose	1.0E6	rads(Si)
SEU Threshold ²	80	MeV-cm ² /mg
SEL Threshold	120	MeV-cm ² /mg
Neutron Fluence	1.0E14	n/cm ²

Notes:

1. Logic will not latchup during radiation exposure within the limits defined in the table.
2. Device storage elements are immune to SEU affects.

ABSOLUTE MAXIMUM RATINGS

SYMBOL	PARAMETER	LIMIT	UNITS
V _{DD}	Supply voltage	-0.3 to 7.0	V
V _{I/O}	Voltage any pin	-.3 to V _{DD} +.3	V
T _{STG}	Storage Temperature range	-65 to +150	°C
T _J	Maximum junction temperature	+175	°C
T _{LS}	Lead temperature (soldering 5 seconds)	+300	°C
Θ _{JC}	Thermal resistance junction to case	20	°C/W
I _I	DC input current	±10	mA
P _D	Maximum power dissipation	1	W

Note:

1. Stresses outside the listed absolute maximum ratings may cause permanent damage to the device. This is a stress rating only, functional operation of the device at these or any other conditions beyond limits indicated in the operational sections is not recommended. Exposure to absolute maximum rating conditions for extended periods may affect device reliability.

RECOMMENDED OPERATING CONDITIONS

SYMBOL	PARAMETER	LIMIT	UNITS
V _{DD}	Supply voltage	4.5 to 5.5	V
V _{IN}	Input voltage any pin	0 to V _{DD}	V
T _C	Temperature range	-55 to + 125	°C

DC ELECTRICAL CHARACTERISTICS ⁷

($V_{DD} = 5.0V \pm 10\%$; $V_{SS} = 0V$ ⁶, $-55^{\circ}C < T_C < +125^{\circ}C$)

SYMBOL	PARAMETER	CONDITION	MIN	MAX	UNIT
V_{IL}	Low-level input voltage ¹ ACTS ACS			0.8 .3 V_{DD}	V
V_{IH}	High-level input voltage ¹ ACTS ACS		.5 V_{DD} .7 V_{DD}		V
I_{IN}	Input leakage current ACTS/ACS	$V_{IN} = V_{DD}$ or V_{SS}	-1	1	μA
V_{OL}	Low-level output voltage ³ ACTS ACS	$I_{OL} = 8mA$ $I_{OL} = 100\mu A$		0.40 0.25	V
V_{OH}	High-level output voltage ³ ACTS ACS	$I_{OH} = -8mA$ $I_{OH} = -100\mu A$.7 V_{DD} $V_{DD} - 0.25$		V
I_{OS}	Short-circuit output current ^{2,4} ACTS/ACS	$V_O = V_{DD}$ and V_{SS}	-200	200	mA
I_{OL}	Output current ¹⁰ (Sink)	$V_{IN} = V_{DD}$ or V_{SS} $V_{OL} = 0.4V$	8		mA
I_{OH}	Output current ¹⁰ (Source)	$V_{IN} = V_{DD}$ or V_{SS} $V_{OH} = V_{DD} - 0.4V$	-8		mA
P_{total}	Power dissipation ^{2, 8, 9}	$C_L = 50pF$		1.8	mW/ MHz
I_{DDQ}	Quiescent Supply Current	$V_{DD} = 5.5V$		10	μA
ΔI_{DDQ}	Quiescent Supply Current Delta ACTS	For input under test $V_{IN} = V_{DD} - 2.1V$ For all other inputs $V_{IN} = V_{DD}$ or V_{SS} $V_{DD} = 5.5V$		1.6	mA
C_{IN}	Input capacitance ⁵	$f = 1MHz @ 0V$		15	pF
C_{OUT}	Output capacitance ⁵	$f = 1MHz @ 0V$		15	pF

Notes:

1. Functional tests are conducted in accordance with MIL-STD-883 with the following input test conditions: $V_{IH} = V_{IH(min)} + 20\%$, $- 0\%$; $V_{IL} = V_{IL(max)} + 0\%$, $- 50\%$, as specified herein, for TTL, CMOS, or Schmitt compatible inputs. Devices may be tested using any input voltage within the above specified range, but are guaranteed to $V_{IH(min)}$ and $V_{IL(max)}$.
2. Supplied as a design limit but not guaranteed or tested.
3. Per MIL-PRF-38535, for current density $\leq 5.0E5$ amps/cm², the maximum product of load capacitance (per output buffer) times frequency should not exceed 3,765 pF/MHz.
4. Not more than one output may be shorted at a time for maximum duration of one second.
5. Capacitance measured for initial qualification and when design changes may affect the value. Capacitance is measured between the designated terminal and V_{SS} at frequency of 1MHz and a signal amplitude of 50mV rms maximum.
6. Maximum allowable relative shift equals 50mV.
7. All specifications valid for radiation dose $\leq 1E6$ rads(Si).
8. Power does not include power contribution of any TTL output sink current.
9. Power dissipation specified per switching output.
10. This value is guaranteed based on characterization data, but not tested.

AC ELECTRICAL CHARACTERISTICS ²

($V_{DD} = 5.0V \pm 10\%$; $V_{SS} = 0V$ ¹, $-55^{\circ}C < T_C < +125^{\circ}C$)

SYMBOL	PARAMETER	MINIMUM	MAXIMUM	UNIT
t_{PHL}	Input to Yn	1	19	ns
t_{PLH}	Input to Yn	1	11	ns

Notes:

1. Maximum allowable relative shift equals 50mV.
2. All specifications valid for radiation dose $\leq 1E6$ rads(Si)

UT54ACS08/UT54ACTS08

Radiation-Hardened Quadruple 2-Input AND Gates

FEATURES

- 1.2m radiation-hardened CMOS
 - Latchup immune
- High speed
- Low power consumption
- Single 5 volt supply
- Available QML Q or V processes
- Flexible package
 - 14-pin DIP
 - 14-lead flatpack

DESCRIPTION

The UT54ACS08 and the UT54ACTS08 are quadruple two-input AND gates. The circuits perform the Boolean functions

$$Y = A \cdot B \text{ or } Y = \overline{\overline{A} + \overline{B}} \text{ in positive logic.}$$

The devices are characterized over full military temperature range of -55°C to $+125^{\circ}\text{C}$.

FUNCTION TABLE

INPUT		OUTPUT
A	B	Y
H	H	H
L	X	L
X	L	L

LOGIC SYMBOL

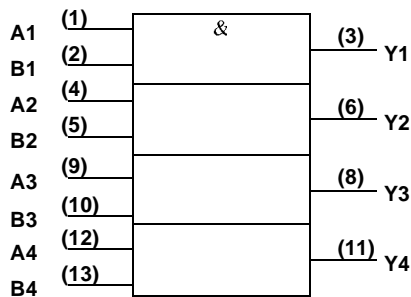

Note:

1. Logic symbol in accordance with ANSI/IEEE standard 91-1984 and IEC Publication 617-12.

PINOUTS

14-Pin DIP
Top View

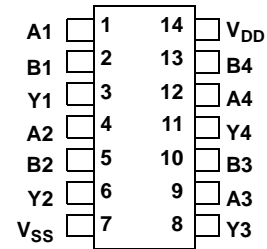

14-Pin Flatpack
Top View

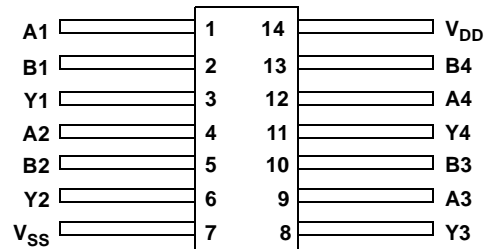

LOGIC DIAGRAM

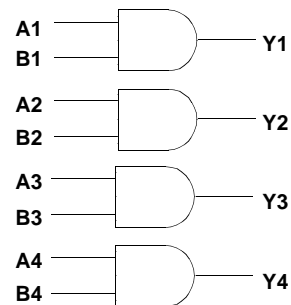

RADIATION HARDNESS SPECIFICATIONS ¹

PARAMETER	LIMIT	UNITS
Total Dose	1.0E6	rads(Si)
SEU Threshold ²	80	MeV-cm ² /mg
SEL Threshold	120	MeV-cm ² /mg
Neutron Fluence	1.0E14	n/cm ²

Notes:

1. Logic will not latchup during radiation exposure within the limits defined in the table.
2. Device storage elements are immune to SEU affects.

ABSOLUTE MAXIMUM RATINGS

SYMBOL	PARAMETER	LIMIT	UNITS
V _{DD}	Supply voltage	-0.3 to 7.0	V
V _{I/O}	Voltage any pin	-.3 to V _{DD} +.3	V
T _{STG}	Storage Temperature range	-65 to +150	°C
T _J	Maximum junction temperature	+175	°C
T _{LS}	Lead temperature (soldering 5 seconds)	+300	°C
θ _{JC}	Thermal resistance junction to case	20	°C/W
I _I	DC input current	±10	mA
P _D	Maximum power dissipation	1	W

Note:

1. Stresses outside the listed absolute maximum ratings may cause permanent damage to the device. This is a stress rating only, functional operation of the device at these or any other conditions beyond limits indicated in the operational sections is not recommended. Exposure to absolute maximum rating conditions for extended periods may affect device reliability.

RECOMMENDED OPERATING CONDITIONS

SYMBOL	PARAMETER	LIMIT	UNITS
V _{DD}	Supply voltage	4.5 to 5.5	V
V _{IN}	Input voltage any pin	0 to V _{DD}	V
T _C	Temperature range	-55 to + 125	°C

DC ELECTRICAL CHARACTERISTICS ⁷

($V_{DD} = 5.0V \pm 10\%$; $V_{SS} = 0V$, $-55^{\circ}C < T_C < +125^{\circ}C$)

SYMBOL	PARAMETER	CONDITION	MIN	MAX	UNIT
V_{IL}	Low-level input voltage ¹ ACTS ACS			0.8 .3 V_{DD}	V
V_{IH}	High-level input voltage ¹ ACTS ACS		.5 V_{DD} .7 V_{DD}		V
I_{IN}	Input leakage current ACTS/ACS	$V_{IN} = V_{DD}$ or V_{SS}	-1	1	μA
V_{OL}	Low-level output voltage ³ ACTS ACS	$I_{OL} = 8.0mA$ $I_{OL} = 100\mu A$		0.40 0.25	V
V_{OH}	High-level output voltage ³ ACTS ACS	$I_{OH} = -8.0mA$ $I_{OH} = -100\mu A$.7 V_{DD} $V_{DD} - 0.25$		V
I_{OS}	Short-circuit output current ^{2,4} ACTS/ACS	$V_O = V_{DD}$ and V_{SS}	-200	200	mA
I_{OL}	Output current ¹⁰ (Sink)	$V_{IN} = V_{DD}$ or V_{SS} $V_{OL} = 0.4V$	8		mA
I_{OH}	Output current ¹⁰ (Source)	$V_{IN} = V_{DD}$ or V_{SS} $V_{OH} = V_{DD} - 0.4V$	-8		mA
P_{total}	Power dissipation ^{2, 8, 9}	$C_L = 50pF$		1.8	mW/ MHz
I_{DDQ}	Quiescent Supply Current	$V_{DD} = 5.5V$		10	μA
ΔI_{DDQ}	Quiescent Supply Current Delta ACTS	For input under test $V_{IN} = V_{DD} - 2.1V$ For all other inputs $V_{IN} = V_{DD}$ or V_{SS} $V_{DD} = 5.5V$		1.6	mA
C_{IN}	Input capacitance ⁵	$f = 1MHz @ 0V$		15	pF
C_{OUT}	Output capacitance ⁵	$f = 1MHz @ 0V$		15	pF

Notes:

1. Functional tests are conducted in accordance with MIL-STD-883 with the following input test conditions: $V_{IH} = V_{IH(min)} + 20\%$, $- 0\%$; $V_{IL} = V_{IL(max)} + 0\%$, $- 50\%$, as specified herein, for TTL, CMOS, or Schmitt compatible inputs. Devices may be tested using any input voltage within the above specified range, but are guaranteed to $V_{IH(min)}$ and $V_{IL(max)}$.
2. Supplied as a design limit but not guaranteed or tested.
3. Per MIL-PRF-38535, for current density $\leq 5.0E5$ amps/cm², the maximum product of load capacitance (per output buffer) times frequency should not exceed 3,765 pF/MHz.
4. Not more than one output may be shorted at a time for maximum duration of one second.
5. Capacitance measured for initial qualification and when design changes may affect the value. Capacitance is measured between the designated terminal and V_{SS} at frequency of 1MHz and a signal amplitude of 50mV rms maximum.
6. Maximum allowable relative shift equals 50mV.
7. All specifications valid for radiation dose $\leq 1E6$ rads(Si).
8. Power does not include power contribution of any TTL output sink current.
9. Power dissipation specified per switching output.
10. This value is guaranteed based on characterization data, but not tested.

AC ELECTRICAL CHARACTERISTICS ²

($V_{DD} = 5.0V \pm 10\%$; $V_{SS} = 0V$ ¹, $-55^{\circ}C < T_C < +125^{\circ}C$)

SYMBOL	PARAMETER	MINIMUM	MAXIMUM	UNIT
t_{PHL}	Input to Yn	1	13	ns
t_{PLH}	Input to Yn	1	10	ns

Notes:

1. Maximum allowable relative shift equals 50mV.
2. All specifications valid for radiation dose $\leq 1E6$ rads(Si).

UT54ACS10/UT54ACTS10

Radiation-Hardened Triple 3-Input NAND Gates

FEATURES

- 1.2μ radiation-hardened CMOS
 - Latchup immune
- High speed
- Low power consumption
- Single 5 volt supply
- Available QML Q or V processes
- Flexible package
 - 14-pin DIP
 - 14-lead flatpack

DESCRIPTION

The UT54ACS10 and the UT54ACTS10 are triple three-input NAND gates. The circuits perform the Boolean functions $Y = \overline{A \cdot B \cdot C}$ or $Y = \overline{A} + \overline{B} + \overline{C}$ in positive logic.

The devices are characterized over full military temperature range of -55°C to +125°C.

FUNCTION TABLE

INPUTS			OUTPUT
A	B	C	Y
H	H	H	L
L	X	X	H
X	L	X	H
X	X	L	H

LOGIC SYMBOL

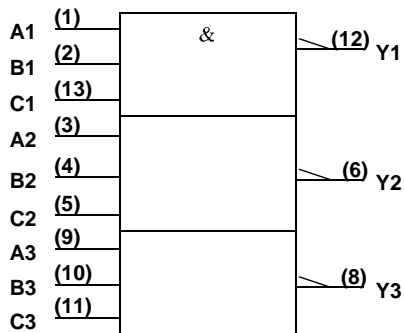

Note:.

1. Logic symbol in accordance with ANSI/IEEE standard 91-1984 and IEC Publication 617-12.

PINOUTS

14-Pin DIP Top View

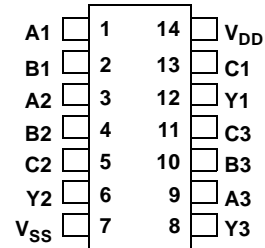

14-Lead Flatpack Top View

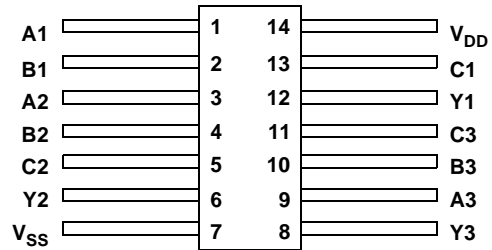

LOGIC DIAGRAM

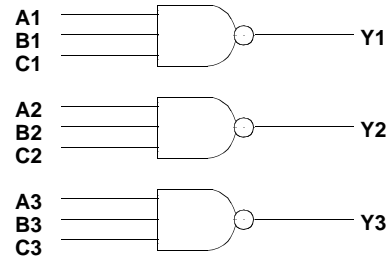

RADIATION HARDNESS SPECIFICATIONS ¹

PARAMETER	LIMIT	UNITS
Total Dose	1.0E6	rads(Si)
SEU Threshold ²	80	MeV-cm ² /mg
SEL Threshold	120	MeV-cm ² /mg
Neutron Fluence	1.0E14	n/cm ²

Notes:

- Logic will not latchup during radiation exposure within the limits defined in the table.
- Device storage elements are immune to SEU affects.

ABSOLUTE MAXIMUM RATINGS

SYMBOL	PARAMETER	LIMIT	UNITS
V _{DD}	Supply voltage	-0.3 to 7.0	V
V _{I/O}	Voltage any pin	-.3 to V _{DD} +.3	V
T _{STG}	Storage Temperature range	-65 to +150	°C
T _J	Maximum junction temperature	+175	°C
T _{LS}	Lead temperature (soldering 5 seconds)	+300	°C
Θ _{JC}	Thermal resistance junction to case	20	°C/W
I _I	DC input current	±10	mA
P _D	Maximum power dissipation	1	W

Note:

- Stresses outside the listed absolute maximum ratings may cause permanent damage to the device. This is a stress rating only, functional operation of the device at these or any other conditions beyond limits indicated in the operational sections is not recommended. Exposure to absolute maximum rating conditions for extended periods may affect device reliability.

RECOMMENDED OPERATING CONDITIONS

SYMBOL	PARAMETER	LIMIT	UNITS
V _{DD}	Supply voltage	4.5 to 5.5	V
V _{IN}	Input voltage any pin	0 to V _{DD}	V
T _C	Temperature range	-55 to + 125	°C

DC ELECTRICAL CHARACTERISTICS ⁷

($V_{DD} = 5.0V \pm 10\%$; $V_{SS} = 0V$ ⁶, $-55^{\circ}C < T_C < +125^{\circ}C$)

SYMBOL	PARAMETER	CONDITION	MIN	MAX	UNIT
V_{IL}	Low-level input voltage ¹ ACTS ACS			0.8 .3 V_{DD}	V
V_{IH}	High-level input voltage ¹ ACTS ACS		.5 V_{DD} .7 V_{DD}		V
I_{IN}	Input leakage current ACTS/ACS	$V_{IN} = V_{DD}$ or V_{SS}	-1	1	μA
V_{OL}	Low-level output voltage ³ ACTS ACS	$I_{OL} = 8.0mA$ $I_{OL} = 100\mu A$		0.40 0.25	V
V_{OH}	High-level output voltage ³ ACTS ACS	$I_{OH} = -8.0mA$ $I_{OH} = -100\mu A$.7 V_{DD} $V_{DD} - 0.25$		V
I_{OS}	Short-circuit output current ^{2,4} ACTS/ACS	$V_O = V_{DD}$ and V_{SS}	-200	200	mA
I_{OL}	Output current ¹⁰ (Sink)	$V_{IN} = V_{DD}$ or V_{SS} $V_{OL} = 0.4V$	8		mA
I_{OH}	Output current ¹⁰ (Source)	$V_{IN} = V_{DD}$ or V_{SS} $V_{OH} = V_{DD} - 0.4V$	-8		mA
P_{total}	Power dissipation ^{2, 8, 9}	$C_L = 50pF$		1.8	mW/ MHz
I_{DDQ}	Quiescent Supply Current	$V_{DD} = 5.5V$		10	μA
ΔI_{DDQ}	Quiescent Supply Current Delta ACTS	For input under test $V_{IN} = V_{DD} - 2.1V$ For all other inputs $V_{IN} = V_{DD}$ or V_{SS} $V_{DD} = 5.5V$		1.6	mA
C_{IN}	Input capacitance ⁵	$f = 1MHz @ 0V$		15	pF
C_{OUT}	Output capacitance ⁵	$f = 1MHz @ 0V$		15	pF

Notes:

1. Functional tests are conducted in accordance with MIL-STD-883 with the following input test conditions: $V_{IH} = V_{IH(min)} + 20\%$, $- 0\%$; $V_{IL} = V_{IL(max)} + 0\%$, $- 50\%$, as specified herein, for TTL, CMOS, or Schmitt compatible inputs. Devices may be tested using any input voltage within the above specified range, but are guaranteed to $V_{IH(min)}$ and $V_{IL(max)}$.
2. Supplied as a design limit but not guaranteed or tested.
3. Per MIL-PRF-38535, for current density $\leq 5.0E5$ amps/cm², the maximum product of load capacitance (per output buffer) times frequency should not exceed 3,765 pF/MHz.
4. Not more than one output may be shorted at a time for maximum duration of one second.
5. Capacitance measured for initial qualification and when design changes may affect the value. Capacitance is measured between the designated terminal and V_{SS} at frequency of 1MHz and a signal amplitude of 50mV rms maximum.
6. Maximum allowable relative shift equals 50mV.
7. All specifications valid for radiation dose $\leq 1E6$ rads(Si).
8. Power does not include power contribution of any TTL output sink current.
9. Power dissipation specified per switching output.
10. This value is guaranteed based on characterization data, but not tested.

AC ELECTRICAL CHARACTERISTICS ²

($V_{DD} = 5.0V \pm 10\%$; $V_{SS} = 0V$ ¹, $-55^{\circ}C < T_C < +125^{\circ}C$)

SYMBOL	PARAMETER	MINIMUM	MAXIMUM	UNIT
t _{PHL}	Input to Yn	1	16	ns
t _{PLH}	Input to Yn	1	12	ns

Notes:

1. Maximum allowable relative shift equals 50mV.
2. All specifications valid for radiation dose $\leq 1E6$ rads(Si).

UT54ACS11/UT54ACTS11

Radiation-Hardened Triple 3-Input AND Gates

FEATURES

- 1.2μ radiation-hardened CMOS
 - Latchup immune
- High speed
- Low power consumption
- Single 5 volt supply
- Available QML Q or V processes
- Flexible package
 - 14-pin DIP
 - 14-lead flatpack

DESCRIPTION

The UT54ACS11 and the UT54ACTS11 are triple three-input AND gates. The circuits perform the Boolean functions

$$Y = A \cdot B \cdot C \text{ or } Y = \overline{\overline{A} + \overline{B} + \overline{C}} \text{ in positive logic.}$$

The devices are characterized over full military temperature range of -55°C to +125°C.

FUNCTION TABLE

INPUTS			OUTPUT
A	B	C	Y
H	H	H	H
L	X	X	L
X	L	X	L
X	X	L	L

LOGIC SYMBOL

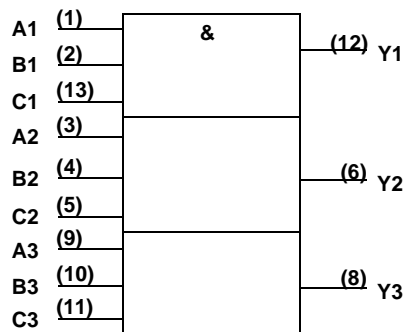

Note:

1. Logic symbol in accordance with ANSI/IEEE standard 91-1984 and IEC Publication 617-12.

PINOUTS

14-Pin DIP Top View

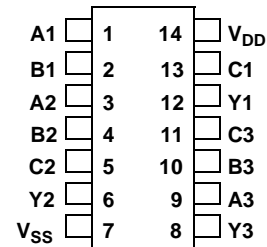

14-Lead Flatpack Top View

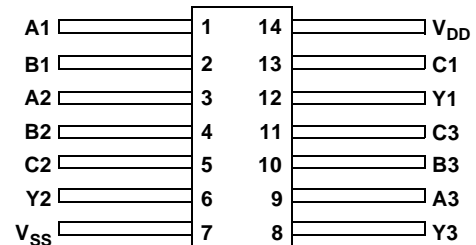

LOGIC DIAGRAM

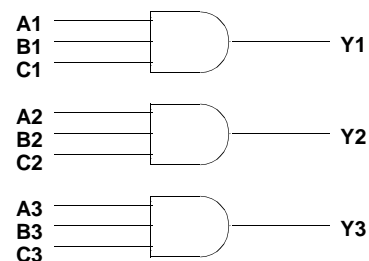

RADIATION HARDNESS SPECIFICATIONS ¹

PARAMETER	LIMIT	UNITS
Total Dose	1.0E6	rads(Si)
SEU Threshold ²	80	MeV-cm ² /mg
SEL Threshold	120	MeV-cm ² /mg
Neutron Fluence	1.0E14	n/cm ²

Notes:

- Logic will not latchup during radiation exposure within the limits defined in the table.
- Device storage elements are immune to SEU affects.

ABSOLUTE MAXIMUM RATINGS

SYMBOL	PARAMETER	LIMIT	UNITS
V _{DD}	Supply voltage	-0.3 to 7.0	V
V _{I/O}	Voltage any pin	-.3 to V _{DD} +.3	V
T _{STG}	Storage Temperature range	-65 to +150	°C
T _J	Maximum junction temperature	+175	°C
T _{LS}	Lead temperature (soldering 5 seconds)	+300	°C
Θ _{JC}	Thermal resistance junction to case	20	°C/W
I _I	DC input current	±10	mA
P _D	Maximum power dissipation	1	W

Note:

- Stresses outside the listed absolute maximum ratings may cause permanent damage to the device. This is a stress rating only, functional operation of the device at these or any other conditions beyond limits indicated in the operational sections is not recommended. Exposure to absolute maximum rating conditions for extended periods may affect device reliability.

RECOMMENDED OPERATING CONDITIONS

SYMBOL	PARAMETER	LIMIT	UNITS
V _{DD}	Supply voltage	4.5 to 5.5	V
V _{IN}	Input voltage any pin	0 to V _{DD}	V
T _C	Temperature range	-55 to + 125	°C

DC ELECTRICAL CHARACTERISTICS ⁷

($V_{DD} = 5.0V \pm 10\%$; $V_{SS} = 0V$ ⁶, $-55^{\circ}C < T_C < +125^{\circ}C$)

SYMBOL	PARAMETER	CONDITION	MIN	MAX	UNIT
V_{IL}	Low-level input voltage ¹ ACTS ACS			0.8 .3 V_{DD}	V
V_{IH}	High-level input voltage ¹ ACTS ACS		.5 V_{DD} .7 V_{DD}		V
I_{IN}	Input leakage current ACTS/ACS	$V_{IN} = V_{DD}$ or V_{SS}	-1	1	μA
V_{OL}	Low-level output voltage ³ ACTS ACS	$I_{OL} = 8.0mA$ $I_{OL} = 100 \mu A$		0.40 0.25	V
V_{OH}	High-level output voltage ³ ACTS ACS	$I_{OH} = -8.0mA$ $I_{OH} = -100\mu A$.7 V_{DD} $V_{DD} - 0.25$		V
I_{OS}	Short-circuit output current ^{2,4} ACTS/ACS	$V_O = V_{DD}$ and V_{SS}	-200	200	mA
I_{OL}	Output current ¹⁰ (Sink)	$V_{IN} = V_{DD}$ or V_{SS} $V_{OL} = 0.4V$	8		mA
I_{OH}	Output current ¹⁰ (Source)	$V_{IN} = V_{DD}$ or V_{SS} $V_{OH} = V_{DD} - 0.4V$	-8		mA
P_{total}	Power dissipation ^{2, 8, 9}	$C_L = 50pF$		1.8	mW/ MHz
I_{DDQ}	Quiescent Supply Current	$V_{DD} = 5.5V$		10	μA
ΔI_{DDQ}	Quiescent Supply Current Delta ACTS	For input under test $V_{IN} = V_{DD} - 2.1V$ For all other inputs $V_{IN} = V_{DD}$ or V_{SS} $V_{DD} = 5.5V$		1.6	mA
C_{IN}	Input capacitance ⁵	$f = 1MHz @ 0V$		15	pF
C_{OUT}	Output capacitance ⁵	$f = 1MHz @ 0V$		15	pF

Notes:

1. Functional tests are conducted in accordance with MIL-STD-883 with the following input test conditions: $V_{IH} = V_{IH(min)} + 20\%$, $- 0\%$; $V_{IL} = V_{IL(max)} + 0\%$, $- 50\%$, as specified herein, for TTL, CMOS, or Schmitt compatible inputs. Devices may be tested using any input voltage within the above specified range, but are guaranteed to $V_{IH(min)}$ and $V_{IL(max)}$.
2. Supplied as a design limit but not guaranteed or tested.
3. Per MIL-PRF-38535, for current density $\leq 5.0E5$ amps/cm², the maximum product of load capacitance (per output buffer) times frequency should not exceed 3,765 pF/MHz.
4. Not more than one output may be shorted at a time for maximum duration of one second.
5. Capacitance measured for initial qualification and when design changes may affect the value. Capacitance is measured between the designated terminal and V_{SS} at frequency of 1MHz and a signal amplitude of 50mV rms maximum.
6. Maximum allowable relative shift equals 50mV.
7. All specifications valid for radiation dose $\leq 1E6$ rads(Si).
8. Power does not include power contribution of any TTL output sink current.
9. Power dissipation specified per switching output.
10. This value is guaranteed based on characterization data, but not tested.

AC ELECTRICAL CHARACTERISTICS ²

($V_{DD} = 5.0V \pm 10\%$; $V_{SS} = 0V$ ¹, $-55^{\circ}C < T_C < +125^{\circ}C$)

SYMBOL	PARAMETER	MINIMUM	MAXIMUM	UNIT
t _{PHL}	Input to Yn	1	13	ns
t _{PLH}	Input to Yn	1	10	ns

Notes:

1. Maximum allowable relative shift equals 50mV.
2. All specifications valid for radiation dose $\leq 1E6$ rads(Si).

UT54ACS14/UT54ACTS14

Radiation-Hardened Hex Inverting Schmitt Triggers

Dec. 1, 2003

FEATURES

- 1.2μ radiation-hardened CMOS (ACTS14) and 0.6μ CRH CMOS process (ACS14)
 - Latchup immune
- High speed
- Low power consumption
- Single 5 volt supply
- Available QML Q or V processes
- Flexible package
 - 14-pin DIP (not available for the ACS14)
 - 14-lead flatpack

DESCRIPTION

The UT54ACS14 and the UT54ACTS14 are hex inverters. The circuits perform the Boolean function $Y = \bar{A}$.

The devices are characterized over full military temperature range of -55°C to +125°C.

FUNCTION TABLE

INPUT	OUTPUT
A	Y
H	L
L	H

LOGIC SYMBOL

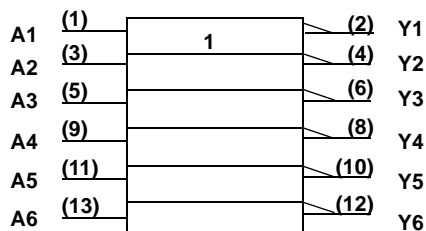

Note:

1. Logic symbol in accordance with ANSI/IEEE standard 91-1984 and IEC Publication 617-12.

PINOUTS

14-Pin DIP Top View

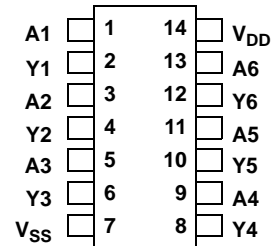

14-Lead Flatpack Top View

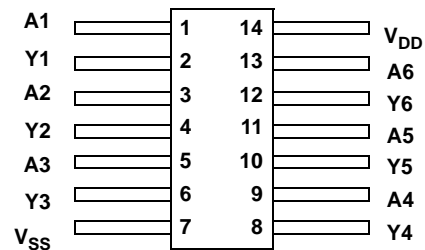

LOGIC DIAGRAM

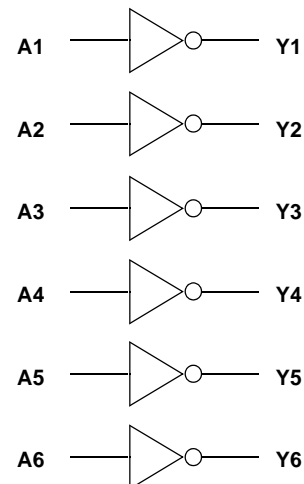

RADIATION HARDNESS SPECIFICATIONS ¹

PARAMETER	LIMIT	UNITS
Total Dose	1.0E6 (ACTS14) 5.0E5 (ACS14)	rads(Si)
SEU Threshold ²	80	MeV-cm ² /mg
SEL Threshold	120	MeV-cm ² /mg
Neutron Fluence	1.0E14	n/cm ²

Notes:

1. Logic will not latchup during radiation exposure within the limits defined in the table.
2. Device storage elements are immune to SEU affects.

ABSOLUTE MAXIMUM RATINGS

SYMBOL	PARAMETER	LIMIT	UNITS
V _{DD}	Supply voltage	-0.3 to 7.0	V
V _{I/O}	Voltage any pin	-.3 to V _{DD} +.3	V
T _{STG}	Storage Temperature range	-65 to +150	°C
T _J	Maximum junction temperature	+175	°C
T _{LS}	Lead temperature (soldering 5 seconds)	+300	°C
Θ _{JC}	Thermal resistance junction to case	20	°C/W
I _I	DC input current	±10	mA
P _D	Maximum power dissipation	1	W

Note:

1. Stresses outside the listed absolute maximum ratings may cause permanent damage to the device. This is a stress rating only, functional operation of the device at these or any other conditions beyond limits indicated in the operational sections is not recommended. Exposure to absolute maximum rating conditions for extended periods may affect device reliability.

RECOMMENDED OPERATING CONDITIONS

SYMBOL	PARAMETER	LIMIT	UNITS
V _{DD}	Supply voltage	4.5 to 5.5	V
V _{IN}	Input voltage any pin	0 to V _{DD}	V
T _C	Temperature range	-55 to + 125	°C

DC ELECTRICAL CHARACTERISTICS ⁷

($V_{DD} = 5.0V \pm 10\%$; $V_{SS} = 0V$ ⁶, $-55^{\circ}C < T_C < +125^{\circ}C$)

SYMBOL	PARAMETER	CONDITION	MIN	MAX	UNIT
V_{T+}	Schmitt Trigger, positive going ¹ threshold ACTS ACS			2.25 .7 V_{DD}	V
V_{T-}	Schmitt Trigger, negative going ¹ threshold ACTS ACS		0.5 .3 V_{DD}		V
V_H	Schmitt Trigger, typical range of hysteresis ² ACTS ACS		0.3 0.6	0.9 1.5	V
I_{IN}	Input leakage current ACTS/ACS	$V_{IN} = V_{DD}$ or V_{SS}	-1	1	μA
V_{OL}	Low-level output voltage ³ ACTS ACS	$I_{OL} = 8.0mA$ $I_{OL} = 100\mu A$		0.40 0.25	V
V_{OH}	High-level output voltage ³ ACTS ACS	$I_{OH} = -8.0mA$ $I_{OH} = -100\mu A$.7 V_{DD} $V_{DD}-0.25$		V
I_{OS}	Short-circuit output current ^{2,4} ACTS/ACS	$V_O = V_{DD}$ and V_{SS}	-200	200	mA
I_{OL}	Output current ¹⁰ (Sink)	$V_{IN} = V_{DD}$ or V_{SS} $V_{OL} = 0.4V$	8		mA
I_{OH}	Output current ¹⁰ (Source)	$V_{IN} = V_{DD}$ or V_{SS} $V_{OH} = V_{DD} - 0.4V$	-8		mA
P_{total}	Power dissipation ^{2, 8, 9}	$C_L = 50pF$		1.8	mW/ MHz
I_{DDQ}	Quiescent Supply Current	$V_{DD} = 5.5V$		10	μA
ΔI_{DDQ}	Quiescent Supply Current Delta ACTS	For input under test $V_{IN} = V_{DD} - 2.1V$ For all other inputs $V_{IN} = V_{DD}$ or V_{SS} $V_{DD} = 5.5V$		3.1	mA
C_{IN}	Input capacitance ⁵	$f = 1MHz @ 0V$		15	pF
C_{OUT}	Output capacitance ⁵	$f = 1MHz @ 0V$		15	pF

Notes:

1. Functional tests are conducted in accordance with MIL-STD-883 with the following input test conditions: $V_{IH} = V_{IH(min)} + 20\%$, $- 0\%$; $V_{IL} = V_{IL(max)} + 0\%$, $- 50\%$, as specified herein, for TTL, CMOS, or Schmitt compatible inputs. Devices may be tested using any input voltage within the above specified range, but are guaranteed to $V_{IH(min)}$ and $V_{IL(max)}$.
2. Supplied as a design limit but not guaranteed or tested.
3. Per MIL-PRF-38535, for current density $\leq 5.0E5$ amps/cm², the maximum product of load capacitance (per output buffer) times frequency should not exceed 3,765 pF/MHz.
4. Not more than one output may be shorted at a time for maximum duration of one second.
5. Capacitance measured for initial qualification and when design changes may affect the value. Capacitance is measured between the designated terminal and V_{SS} at frequency of 1MHz and a signal amplitude of 50mV rms maximum.
6. Maximum allowable relative shift equals 50mV.
7. All ACTS specifications are valid for radiation dose $\leq 1E6$ rads(Si), and all ACS specifications are valid for radiation dose $\leq 5E5$ rads(Si).
8. Power does not include power contribution of any TTL output sink current.
9. Power dissipation specified per switching output.
10. This value is guaranteed based on characterization data, but not tested.

AC ELECTRICAL CHARACTERISTICS ²

($V_{DD} = 5.0V \pm 10\%$; $V_{SS} = 0V$, $-55^{\circ}C < T_C < +125^{\circ}C$)

SYMBOL	PARAMETER	MINIMUM	MAXIMUM	UNIT
t_{PHL}	Input to Y_n	2	14	ns
t_{PLH}	Input to Y_n	2	13	ns

Notes:

1. Maximum allowable relative shift equals 50mV.
2. For the ACTS version, all specifications are valid for radiation dose $\leq 1E6$ rads(Si). For the ACS version, all specifications are valid for radiation dose $\leq 5E5$ rads(Si).

UT54ACS20/UT54ACTS20

Radiation-Hardened Dual 4-Input NAND Gates

FEATURES

- 1.2μ radiation-hardened CMOS
 - Latchup immune
- High speed
- Low power consumption
- Single 5 volt supply
- Available QML Q or V processes
- Flexible package
 - 14-pin DIP
 - 14-lead flatpack

DESCRIPTION

The UT54ACS20 and the UT54ACTS20 are dual 4-input NAND gates. The circuits perform the Boolean functions $Y = \overline{A \cdot B \cdot C \cdot D}$ or $Y = \overline{A} + \overline{B} + \overline{C} + \overline{D}$ in positive logic.

The devices are characterized over full military temperature range of -55°C to +125°C.

FUNCTION TABLE

INPUTS				OUTPUT
A	B	C	D	Y
H	H	H	H	L
L	X	X	X	H
X	L	X	X	H
X	X	L	X	H
X	X	X	L	H

LOGIC SYMBOL

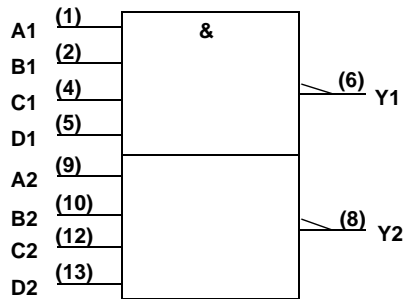

Note:

1. Logic symbol in accordance with ANSI/IEEE standard 91-1984 and IEC Publication 617-12.

PINOUTS

14-Pin DIP Top View

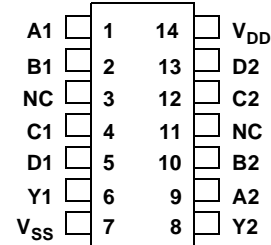

14-Lead Flatpack Top View

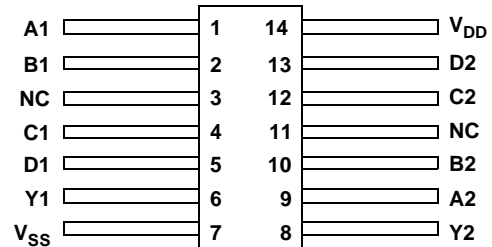

LOGIC DIAGRAM

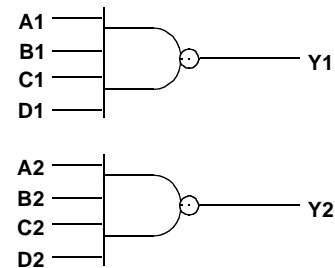

RADIATION HARDNESS SPECIFICATIONS ¹

PARAMETER	LIMIT	UNITS
Total Dose	1.0E6	rads(Si)
SEU Threshold ²	80	MeV-cm ² /mg
SEL Threshold	120	MeV-cm ² /mg
Neutron Fluence	1.0E14	n/cm ²

Notes:

1. Logic will not latchup during radiation exposure within the limits defined in the table.
2. Device storage elements are immune to SEU affects.

ABSOLUTE MAXIMUM RATINGS

SYMBOL	PARAMETER	LIMIT	UNITS
V _{DD}	Supply voltage	-0.3 to 7.0	V
V _{I/O}	Voltage any pin	-.3 to V _{DD} +.3	V
T _{STG}	Storage Temperature range	-65 to +150	°C
T _J	Maximum junction temperature	+175	°C
T _{LS}	Lead temperature (soldering 5 seconds)	+300	°C
Θ _{JC}	Thermal resistance junction to case	20	°C/W
I _I	DC input current	±10	mA
P _D	Maximum power dissipation	1	W

Note:

1. Stresses outside the listed absolute maximum ratings may cause permanent damage to the device. This is a stress rating only, functional operation of the device at these or any other conditions beyond limits indicated in the operational sections is not recommended. Exposure to absolute maximum rating conditions for extended periods may affect device reliability.

RECOMMENDED OPERATING CONDITIONS

SYMBOL	PARAMETER	LIMIT	UNITS
V _{DD}	Supply voltage	4.5 to 5.5	V
V _{IN}	Input voltage any pin	0 to V _{DD}	V
T _C	Temperature range	-55 to + 125	°C

DC ELECTRICAL CHARACTERISTICS ⁷

($V_{DD} = 5.0V \pm 10\%$; $V_{SS} = 0V$ ⁶, $-55^{\circ}C < T_C < +125^{\circ}C$)

SYMBOL	PARAMETER	CONDITION	MIN	MAX	UNIT
V_{IL}	Low-level input voltage ¹ ACTS ACS			0.8 .3 V_{DD}	V
V_{IH}	High-level input voltage ¹ ACTS ACS		.5 V_{DD} .7 V_{DD}		V
I_{IN}	Input leakage current ACTS/ACS	$V_{IN} = V_{DD}$ or V_{SS}	-1	1	μA
V_{OL}	Low-level output voltage ³ ACTS ACS	$I_{OL} = 8.0mA$ $I_{OL} = 100\mu A$		0.40 0.25	V
V_{OH}	High-level output voltage ³ ACTS ACS	$I_{OH} = -8.0mA$ $I_{OH} = -100\mu A$.7 V_{DD} $V_{DD} - 0.25$		V
I_{OS}	Short-circuit output current ^{2,4} ACTS/ACS	$V_O = V_{DD}$ and V_{SS}	-200	200	mA
I_{OL}	Output current ¹⁰ (Sink)	$V_{IN} = V_{DD}$ or V_{SS} $V_{OL} = 0.4V$	8		mA
I_{OH}	Output current ¹⁰ (Source)	$V_{IN} = V_{DD}$ or V_{SS} $V_{OH} = V_{DD} - 0.4V$	-8		mA
P_{total}	Power dissipation ^{2, 8, 9}	$C_L = 50pF$		1.9	mW/ MHz
I_{DDQ}	Quiescent Supply Current	$V_{DD} = 5.5V$		10	μA
ΔI_{DDQ}	Quiescent Supply Current Delta ACTS	For input under test $V_{IN} = V_{DD} - 2.1V$ For all other inputs $V_{IN} = V_{DD}$ or V_{SS} $V_{DD} = 5.5V$		1.6	mA
C_{IN}	Input capacitance ⁵	$f = 1MHz @ 0V$		15	pF
C_{OUT}	Output capacitance ⁵	$f = 1MHz @ 0V$		15	pF

Notes:

1. Functional tests are conducted in accordance with MIL-STD-883 with the following input test conditions: $V_{IH} = V_{IH(min)} + 20\%$, $- 0\%$; $V_{IL} = V_{IL(max)} + 0\%$, $- 50\%$, as specified herein, for TTL, CMOS, or Schmitt compatible inputs. Devices may be tested using any input voltage within the above specified range, but are guaranteed to $V_{IH(min)}$ and $V_{IL(max)}$.
2. Supplied as a design limit but not guaranteed or tested.
3. Per MIL-PRF-38535, for current density $\leq 5.0E5$ amps/cm², the maximum product of load capacitance (per output buffer) times frequency should not exceed 3,765 pF/MHz.
4. Not more than one output may be shorted at a time for maximum duration of one second.
5. Capacitance measured for initial qualification and when design changes may affect the value. Capacitance is measured between the designated terminal and V_{SS} at frequency of 1MHz and a signal amplitude of 50mV rms maximum.
6. Maximum allowable relative shift equals 50mV.
7. All specifications valid for radiation dose $\leq 1E6$ rads(Si).
8. Power does not include power contribution of any TTL output sink current.
9. Power dissipation specified per switching output.
10. This value is guaranteed based on characterization data, but not tested.

AC ELECTRICAL CHARACTERISTICS ²

($V_{DD} = 5.0V \pm 10\%$; $V_{SS} = 0V$ ¹, $-55^{\circ}C < T_C < +125^{\circ}C$)

SYMBOL	PARAMETER	MINIMUM	MAXIMUM	UNIT
t _{PHL}	Input to Y _n	1	15	ns
t _{PLH}	Input to Y _n	1	11	ns

Notes:

1. Maximum allowable relative shift equals 50mV.
2. All specifications valid for radiation dose $\leq 1E6$ rads(Si).

UT54ACS27/UT54ACTS27

Radiation-Hardened Triple 3-Input NOR Gates

FEATURES

- 1.2μ radiation-hardened CMOS
 - Latchup immune
- High speed
- Low power consumption
- Single 5 volt supply
- Available QML Q or V processes
- Flexible package
 - 14-pin DIP
 - 14-lead flatpack

DESCRIPTION

The UT54ACS27 and the UT54ACTS27 are triple, three-input NOR gates. The circuits perform the Boolean functions $Y = \overline{A+B+C}$ or $Y = \overline{A} \cdot \overline{B} \cdot \overline{C}$ in positive logic.

The devices are characterized over full military temperature range of -55°C to +125°C.

FUNCTION TABLE

INPUTS			OUTPUT
A	B	C	Y
H	X	X	L
X	H	X	L
X	X	H	L
L	L	L	H

LOGIC SYMBOL

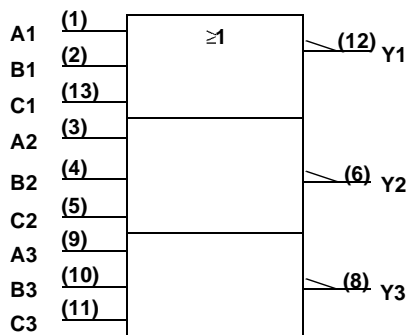

Note:

1. Logic symbol in accordance with ANSI/IEEE standard 91-1984 and IEC Publication 617-12.

PINOUTS

14-Pin DIP Top View

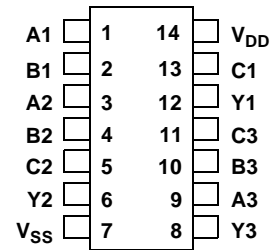

14-Lead Flatpack Top View

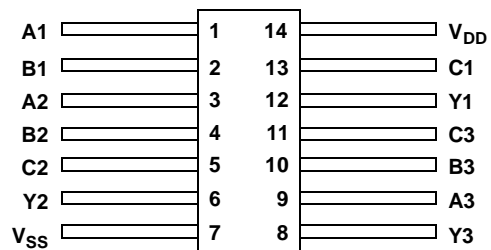

LOGIC DIAGRAM

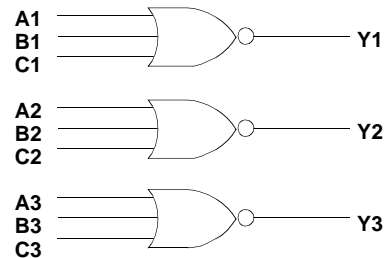

RADIATION HARDNESS SPECIFICATIONS ¹

PARAMETER	LIMIT	UNITS
Total Dose	1.0E6	rads(Si)
SEU Threshold ²	80	MeV-cm ² /mg
SEL Threshold	120	MeV-cm ² /mg
Neutron Fluence	1.0E14	n/cm ²

Notes:

1. Logic will not latchup during radiation exposure within the limits defined in the table.
2. Device storage elements are immune to SEU affects.

ABSOLUTE MAXIMUM RATINGS

SYMBOL	PARAMETER	LIMIT	UNITS
V _{DD}	Supply voltage	-0.3 to 7.0	V
V _{I/O}	Voltage any pin	-3 to V _{DD} +.3	V
T _{STG}	Storage Temperature range	-65 to +150	°C
T _J	Maximum junction temperature	+175	°C
T _{LS}	Lead temperature (soldering 5 seconds)	+300	°C
Θ _{JC}	Thermal resistance junction to case	20	°C/W
I _I	DC input current	±10	mA
P _D	Maximum power dissipation	1	W

Note:

1. Stresses outside the listed absolute maximum ratings may cause permanent damage to the device. This is a stress rating only, functional operation of the device at these or any other conditions beyond limits indicated in the operational sections is not recommended. Exposure to absolute maximum rating conditions for extended periods may affect device reliability.

RECOMMENDED OPERATING CONDITIONS

SYMBOL	PARAMETER	LIMIT	UNITS
V _{DD}	Supply voltage	4.5 to 5.5	V
V _{IN}	Input voltage any pin	0 to V _{DD}	V
T _C	Temperature range	-55 to + 125	°C

DC ELECTRICAL CHARACTERISTICS ⁷

($V_{DD} = 5.0V \pm 10\%$; $V_{SS} = 0V$ ⁶, $-55^{\circ}C < T_C < +125^{\circ}C$)

SYMBOL	PARAMETER	CONDITION	MIN	MAX	UNIT
V_{IL}	Low-level input voltage ¹ ACTS ACS			0.8 .3 V_{DD}	V
V_{IH}	High-level input voltage ¹ ACTS ACS		.5 V_{DD} .7 V_{DD}		V
I_{IN}	Input leakage current ACTS/ACS	$V_{IN} = V_{DD}$ or V_{SS}	-1	1	μA
V_{OL}	Low-level output voltage ³ ACTS ACS	$I_{OL} = 8.0mA$ $I_{OL} = 100\mu A$		0.40 0.25	V
V_{OH}	High-level output voltage ³ ACTS ACS	$I_{OH} = -8.0mA$ $I_{OH} = -100\mu A$.7 V_{DD} $V_{DD} - 0.25$		V
I_{OS}	Short-circuit output current ^{2,4} ACTS/ACS	$V_O = V_{DD}$ and V_{SS}	-200	200	mA
P_{total}	Power dissipation ^{2, 8, 9}	$C_L = 50pF$		1.8	mW/ MHz
I_{OL}	Output current ¹⁰ (Sink)	$V_{IN} = V_{DD}$ or V_{SS} $V_{OL} = 0.4V$	8		mA
I_{OH}	Output current ¹⁰ (Source)	$V_{IN} = V_{DD}$ or V_{SS} $V_{OH} = V_{DD} - 0.4V$	-8		mA
I_{DDQ}	Quiescent Supply Current	$V_{DD} = 5.5V$		10	μA
ΔI_{DDQ}	Quiescent Supply Current Delta ACTS	For input under test $V_{IN} = V_{DD} - 2.1V$ For all other inputs $V_{IN} = V_{DD}$ or V_{SS} $V_{DD} = 5.5V$		1.6	mA
C_{IN}	Input capacitance ⁵	$f = 1MHz @ 0V$		15	pF
C_{OUT}	Output capacitance ⁵	$f = 1MHz @ 0V$		15	pF

Notes:

1. Functional tests are conducted in accordance with MIL-STD-883 with the following input test conditions: $V_{IH} = V_{IH(min)} + 20\%$, $- 0\%$; $V_{IL} = V_{IL(max)} + 0\%$, $- 50\%$, as specified herein, for TTL, CMOS, or Schmitt compatible inputs. Devices may be tested using any input voltage within the above specified range, but are guaranteed to $V_{IH(min)}$ and $V_{IL(max)}$.
2. Supplied as a design limit but not guaranteed or tested.
3. Per MIL-PRF-38535, for current density $\leq 5.0E5$ amps/cm², the maximum product of load capacitance (per output buffer) times frequency should not exceed 3,765 pF/MHz.
4. Not more than one output may be shorted at a time for maximum duration of one second.
5. Capacitance measured for initial qualification and when design changes may affect the value. Capacitance is measured between the designated terminal and V_{SS} at frequency of 1MHz and a signal amplitude of 50mV rms maximum.
6. Maximum allowable relative shift equals 50mV.
7. All specifications valid for radiation dose $\leq 1E6$ rads(Si).
8. Power does not include power contribution of any TTL output sink current.
9. Power dissipation specified per switching output.
10. This value is guaranteed based on characterization data, but not tested.

AC ELECTRICAL CHARACTERISTICS ²

($V_{DD} = 5.0V \pm 10\%$; $V_{SS} = 0V$ ¹, $-55^{\circ}C < T_C < +125^{\circ}C$)

SYMBOL	PARAMETER	MINIMUM	MAXIMUM	UNIT
t_{PHL}	Input to Yn	1	15	ns
t_{PLH}	Input to Yn	1	13	ns

Notes:

1. Maximum allowable relative shift equals 50mV.
2. All specifications valid for radiation dose $\leq 1E6$ rads(Si).

UT54ACS34/UT54ACTS34

Radiation-Hardened Hex Noninverting Buffers

FEATURES

- 1.2μ radiation-hardened CMOS
 - Latchup immune
- High speed
- Low power consumption
- Single 5 volt supply
- Available QML Q or V processes
- Flexible package
 - 14-pin DIP
 - 14-lead flatpack

DESCRIPTION

The UT54ACS34 and the UT54ACTS34 are hex noninverting buffers. The circuits perform the Boolean functions $Y = A$.

The devices are characterized over full military temperature range of -55°C to +125°C.

FUNCTION TABLE

INPUT	OUTPUT
A	Y
H	H
L	L

LOGIC SYMBOL

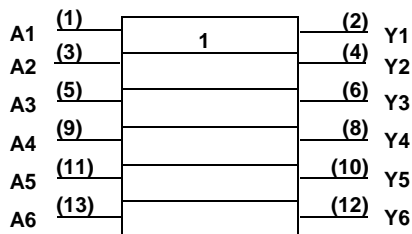

Note:

1. Logic symbol in accordance with ANSI/IEEE standard 91-1984 and IEC Publication 617-12.

PINOUTS

14-Pin DIP Top View

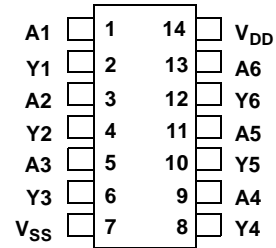

14-Lead Flatpack Top View

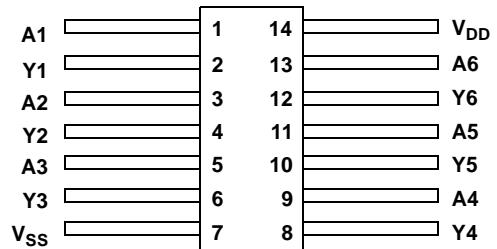

LOGIC DIAGRAM

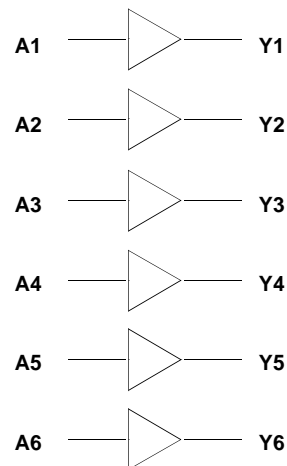

RADIATION HARDNESS SPECIFICATIONS ¹

PARAMETER	LIMIT	UNITS
Total Dose	1.0E6	rads(Si)
SEU Threshold ²	80	MeV-cm ² /mg
SEL Threshold	120	MeV-cm ² /mg
Neutron Fluence	1.0E14	n/cm ²

Notes:

1. Logic will not latchup during radiation exposure within the limits defined in the table.
2. Device storage elements are immune to SEU affects.

ABSOLUTE MAXIMUM RATINGS

SYMBOL	PARAMETER	LIMIT	UNITS
V _{DD}	Supply voltage	-0.3 to 7.0	V
V _{I/O}	Voltage any pin	-.3 to V _{DD} +.3	V
T _{STG}	Storage Temperature range	-65 to +150	°C
T _J	Maximum junction temperature	+175	°C
T _{LS}	Lead temperature (soldering 5 seconds)	+300	°C
θ _{JC}	Thermal resistance junction to case	20	°C/W
I _I	DC input current	±10	mA
P _D	Maximum power dissipation	1	W

Note:

1. Stresses outside the listed absolute maximum ratings may cause permanent damage to the device. This is a stress rating only, functional operation of the device at these or any other conditions beyond limits indicated in the operational sections is not recommended. Exposure to absolute maximum rating conditions for extended periods may affect device reliability.

RECOMMENDED OPERATING CONDITIONS

SYMBOL	PARAMETER	LIMIT	UNITS
V _{DD}	Supply voltage	4.5 to 5.5	V
V _{IN}	Input voltage any pin	0 to V _{DD}	V
T _C	Temperature range	-55 to + 125	°C

DC ELECTRICAL CHARACTERISTICS ⁷

($V_{DD} = 5.0V \pm 10\%$; $V_{SS} = 0V$ ⁶, $-55^{\circ}C < T_C < +125^{\circ}C$)

SYMBOL	PARAMETER	CONDITION	MIN	MAX	UNIT
V_{IL}	Low-level input voltage ¹ ACTS ACS			0.8 .3 V_{DD}	V
V_{IH}	High-level input voltage ¹ ACTS ACS		.5 V_{DD} .7 V_{DD}		V
I_{IN}	Input leakage current ACTS/ACS	$V_{IN} = V_{DD}$ or V_{SS}	-1	1	μA
V_{OL}	Low-level output voltage ³ ACTS ACS	$I_{OL} = 8.0mA$ $I_{OL} = 100\mu A$		0.40 0.25	V
V_{OH}	High-level output voltage ³ ACTS ACS	$I_{OH} = -8.0mA$ $I_{OH} = -100\mu A$.7 V_{DD} $V_{DD} - 0.25$		V
I_{OS}	Short-circuit output current ^{2,4} ACTS/ACS	$V_O = V_{DD}$ and V_{SS}	-200	200	mA
I_{OL}	Output current ¹⁰ (Sink)	$V_{IN} = V_{DD}$ or V_{SS} $V_{OL} = 0.4V$	8		mA
I_{OH}	Output current ¹⁰ (Source)	$V_{IN} = V_{DD}$ or V_{SS} $V_{OH} = V_{DD} - 0.4V$	-8		mA
P_{total}	Power dissipation ^{2, 8, 9}	$C_L = 50pF$		1.8	mW/ MHz
I_{DDQ}	Quiescent Supply Current	$V_{DD} = 5.5V$		10	μA
ΔI_{DDQ}	Quiescent Supply Current Delta ACTS	For input under test $V_{IN} = V_{DD} - 2.1V$ For all other inputs $V_{IN} = V_{DD}$ or V_{SS} $V_{DD} = 5.5V$		1.6	mA
C_{IN}	Input capacitance ⁵	$f = 1MHz @ 0V$		15	pF
C_{OUT}	Output capacitance ⁵	$f = 1MHz @ 0V$		15	pF

Notes:

1. Functional tests are conducted in accordance with MIL-STD-883 with the following input test conditions: $V_{IH} = V_{IH(min)} + 20\%$, $- 0\%$; $V_{IL} = V_{IL(max)} + 0\%$, $- 50\%$, as specified herein, for TTL, CMOS, or Schmitt compatible inputs. Devices may be tested using any input voltage within the above specified range, but are guaranteed to $V_{IH(min)}$ and $V_{IL(max)}$.
2. Supplied as a design limit but not guaranteed or tested.
3. Per MIL-PRF-38535, for current density $\leq 5.0E5$ amps/cm², the maximum product of load capacitance (per output buffer) times frequency should not exceed 3,765 pF/MHz.
4. Not more than one output may be shorted at a time for maximum duration of one second.
5. Capacitance measured for initial qualification and when design changes may affect the value. Capacitance is measured between the designated terminal and V_{SS} at frequency of 1MHz and a signal amplitude of 50mV rms maximum.
6. Maximum allowable relative shift equals 50mV.
7. All specifications valid for radiation dose $\leq 1E6$ rads(Si).
8. Power does not include power contribution of any TTL output sink current.
9. Power dissipation specified per switching output.
10. This value is guaranteed based on characterization data, but not tested.

AC ELECTRICAL CHARACTERISTICS ²

($V_{DD} = 5.0V \pm 10\%$; $V_{SS} = 0V$ ¹, $-55^{\circ}C < T_C < +125^{\circ}C$)

SYMBOL	PARAMETER	MINIMUM	MAXIMUM	UNIT
t _{PHL}	Input to Yn	1	11	ns
t _{PLH}	Input to Yn	1	11	ns

Notes:

1. Maximum allowable relative shift equals 50mV.
2. All specifications valid for radiation dose $\leq 1E6$ rads(Si).

UT54ACS54/UT54ACTS54

Radiation-Hardened

4-Wide AND-OR-INVERT Gates

FEATURES

- 1.2μ radiation-hardened CMOS
 - Latchup immune
- High speed
- Low power consumption
- Single 5 volt supply
- Available QML Q or V processes
- Flexible package
 - 14-pin DIP
 - 14-lead flatpack

DESCRIPTION

The UT54ACS54 and the UT54ACTS54 are 4-wide AND-OR-INVERT gates. The devices perform the Boolean function:

$$Y = \overline{AB+CD+EF+GH}$$

The devices are characterized over full military temperature range of -55°C to +125°C.

FUNCTION TABLE

INPUT								OUTPUT
A	B	C	D	E	F	G	H	Y
H	H	X	X	X	X	X	X	L
X	X	H	H	X	X	X	X	L
X	X	X	X	H	H	X	X	L
X	X	X	X	X	X	H	H	L
L	X	L	X	L	X	L	X	H
X	L	X	L	X	L	X	L	H

LOGIC SYMBOL

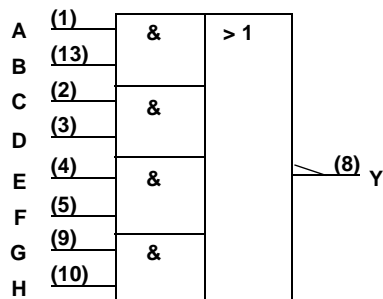

Note:

1. Logic symbol in accordance with ANSI/IEEE standard 91-1984 and IEC Publication 617-12.

PINOUTS

14-Pin DIP Top View

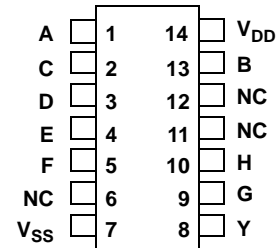

14-Lead Flatpack Top View

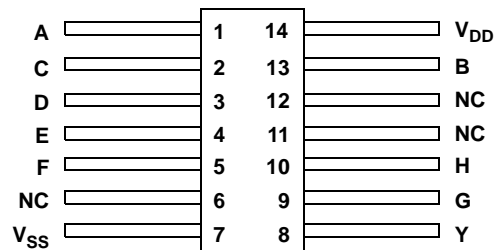

LOGIC DIAGRAM

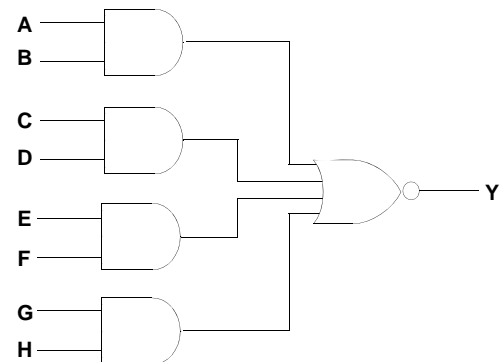

RADIATION HARDNESS SPECIFICATIONS ¹

PARAMETER	LIMIT	UNITS
Total Dose	1.0E6	rads(Si)
SEU Threshold ²	80	MeV-cm ² /mg
SEL Threshold	120	MeV-cm ² /mg
Neutron Fluence	1.0E14	n/cm ²

Notes:

1. Logic will not latchup during radiation exposure within the limits defined in the table.
2. Device storage elements are immune to SEU affects.

ABSOLUTE MAXIMUM RATINGS

SYMBOL	PARAMETER	LIMIT	UNITS
V _{DD}	Supply voltage	-0.3 to 7.0	V
V _{I/O}	Voltage any pin	-.3 to V _{DD} +.3	V
T _{STG}	Storage Temperature range	-65 to +150	°C
T _J	Maximum junction temperature	+175	°C
T _{LS}	Lead temperature (soldering 5 seconds)	+300	°C
Θ _{JC}	Thermal resistance junction to case	15.5	°C/W
I _I	DC input current	±10	mA
P _D	Maximum power dissipation	3.2	W

Note:

1. Stresses outside the listed absolute maximum ratings may cause permanent damage to the device. This is a stress rating only, functional operation of the device at these or any other conditions beyond limits indicated in the operational sections is not recommended. Exposure to absolute maximum rating conditions for extended periods may affect device reliability.
2. PD = TS-TC/Θ_{JC}.

RECOMMENDED OPERATING CONDITIONS

SYMBOL	PARAMETER	LIMIT	UNITS
V _{DD}	Supply voltage	4.5 to 5.5	V
V _{IN}	Input voltage any pin	0 to V _{DD}	V
T _C	Temperature range	-55 to + 125	°C

DC ELECTRICAL CHARACTERISTICS ⁷

($V_{DD} = 5.0V \pm 10\%$; $V_{SS} = 0V$ ⁶, $-55^{\circ}C < T_C < +125^{\circ}C$)

SYMBOL	PARAMETER	CONDITION	MIN	MAX	UNIT
V_{IL}	Low-level input voltage ¹ ACTS ACS			0.8 .3 V_{DD}	V
V_{IH}	High-level input voltage ¹ ACTS ACS		.5 V_{DD} .7 V_{DD}		V
I_{IN}	Input leakage current ACTS/ACS	$V_{IN} = V_{DD}$ or V_{SS}	-1	1	μA
V_{OL}	Low-level output voltage ³ ACTS ACS	$I_{OL} = 8.0mA$ $I_{OL} = 100\mu A$		0.40 0.25	V
V_{OH}	High-level output voltage ³ ACTS ACS	$I_{OH} = -8.0mA$ $I_{OH} = -100\mu A$.7 V_{DD} $V_{DD} - 0.25$		V
I_{OS}	Short-circuit output current ^{2,4} ACTS/ACS	$V_O = V_{DD}$ and V_{SS}	-200	200	mA
P_{total}	Power dissipation ^{2, 8, 9}	$C_L = 50pF$		2.0	mW/ MHz
I_{OL}	Output current ¹⁰ (Sink)	$V_{IN} = V_{DD}$ or V_{SS} $V_{OL} = 0.4V$	8		mA
I_{OH}	Output current ¹⁰ (Source)	$V_{IN} = V_{DD}$ or V_{SS} $V_{OH} = V_{DD} - 0.4V$	-8		mA
I_{DDQ}	Quiescent Supply Current	$V_{DD} = 5.5V$		10	μA
ΔI_{DDQ}	Quiescent Supply Current Delta ACTS	For input under test $V_{IN} = V_{DD} - 2.1V$ For all other inputs $V_{IN} = V_{DD}$ or V_{SS} $V_{DD} = 5.5V$		1.6	mA
C_{IN}	Input capacitance ⁵	$f = 1MHz @ 0V$		15	pF
C_{OUT}	Output capacitance ⁵	$f = 1MHz @ 0V$		15	pF

Notes:

1. Functional tests are conducted in accordance with MIL-STD-883 with the following input test conditions: $V_{IH} = V_{IH(min)} + 20\%$, $- 0\%$; $V_{IL} = V_{IL(max)} + 0\%$, $- 50\%$, as specified herein, for TTL, CMOS, or Schmitt compatible inputs. Devices may be tested using any input voltage within the above specified range, but are guaranteed to $V_{IH(min)}$ and $V_{IL(max)}$.
2. Supplied as a design limit but not guaranteed or tested.
3. Per MIL-PRF-38535, for current density $\leq 5.0E5$ amps/cm², the maximum product of load capacitance (per output buffer) times frequency should not exceed 3,765 pF/MHz.
4. Not more than one output may be shorted at a time for maximum duration of one second.
5. Capacitance measured for initial qualification and when design changes may affect the value. Capacitance is measured between the designated terminal and V_{SS} at frequency of 1MHz and a signal amplitude of 50mV rms maximum.
6. Maximum allowable relative shift equals 50mV.
7. All specifications valid for radiation dose $\leq 1E6$ rads(Si).
8. Power does not include power contribution of any TTL output sink current.
9. Power dissipation specified per switching output
10. This value is guaranteed based on characterization data, but not tested.

AC ELECTRICAL CHARACTERISTICS ²

($V_{DD} = 5.0V \pm 10\%$; $V_{SS} = 0V$ ¹, $-55^{\circ}C < T_C < +125^{\circ}C$)

SYMBOL	PARAMETER	MINIMUM	MAXIMUM	UNIT
t_{PHL}	From any input to Y output	1	16	ns
t_{PLH}	From any input to Y output	1	13	ns

Notes:

1. Maximum allowable relative shift equals 50mV.
2. All specifications valid for radiation dose $\leq 1E6$ rads(Si).

UT54ACS74/UT54ACTS74

Radiation-Hardened

Dual D Flip-Flops with Clear & Preset

FEATURES

- 1.2μ radiation-hardened CMOS (ACS74) and 0.6μm CRH CMOS process (ACTS74)
 - Latchup immune
- High speed
- Low power consumption
- Single 5 volt supply
- Available QML Q or V processes
- Flexible package
 - 14-pin DIP (not available for the ACTS74)
 - 14-lead flatpack

DESCRIPTION

The UT54ACS74 and the UT54ACTS74 contain two independent D-type positive triggered flip-flops. A low level at the Preset or Clear inputs sets or resets the outputs regardless of the levels of the other inputs. When Preset and Clear are inactive (high), data at the D input meeting the setup time requirement is transferred to the outputs on the positive-going edge of the clock pulse. Following the hold time interval, data at the D input may be changed without affecting the levels at the outputs.

The devices are characterized over full military temperature range of -55°C to +125°C.

FUNCTION TABLE

INPUTS				OUTPUT	
$\overline{\text{PRE}}$	$\overline{\text{CLR}}$	CLK	D	Q	$\overline{\text{Q}}$
L	H	X	X	H	L
H	L	X	X	L	H
L	L	X	X	H ¹	H ¹
H	H	↑	H	H	L
H	H	↑	L	L	H
H	H	L	X	Q ₀	$\overline{\text{Q}}_0$

Note:

1. The output levels in this configuration are not guaranteed to meet the minimum levels for V_{OH} if the lows at preset and clear are near V_{IL} maximum. In addition, this configuration is nonstable; that is, it will not persist when either preset or clear returns to its inactive (high) level.

PINOUTS

14-Pin DIP Top View

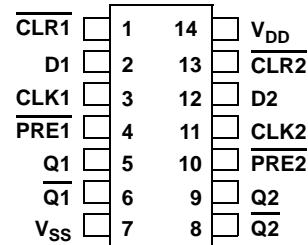

14-Lead Flatpack Top View

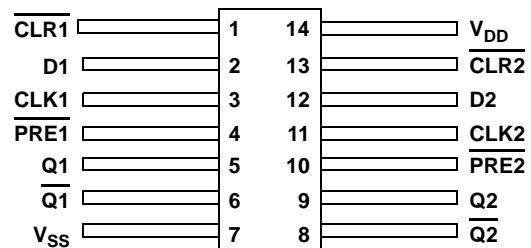

LOGIC SYMBOL

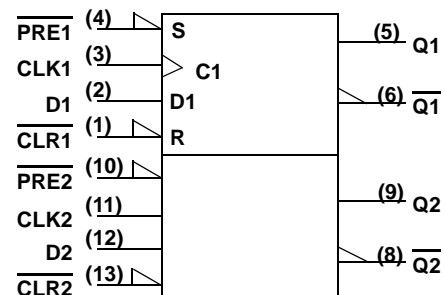

Note:

1. Logic symbol in accordance with ANSI/IEEE standard 91-1984 and IEC Publication 617-12.

LOGIC DIAGRAM

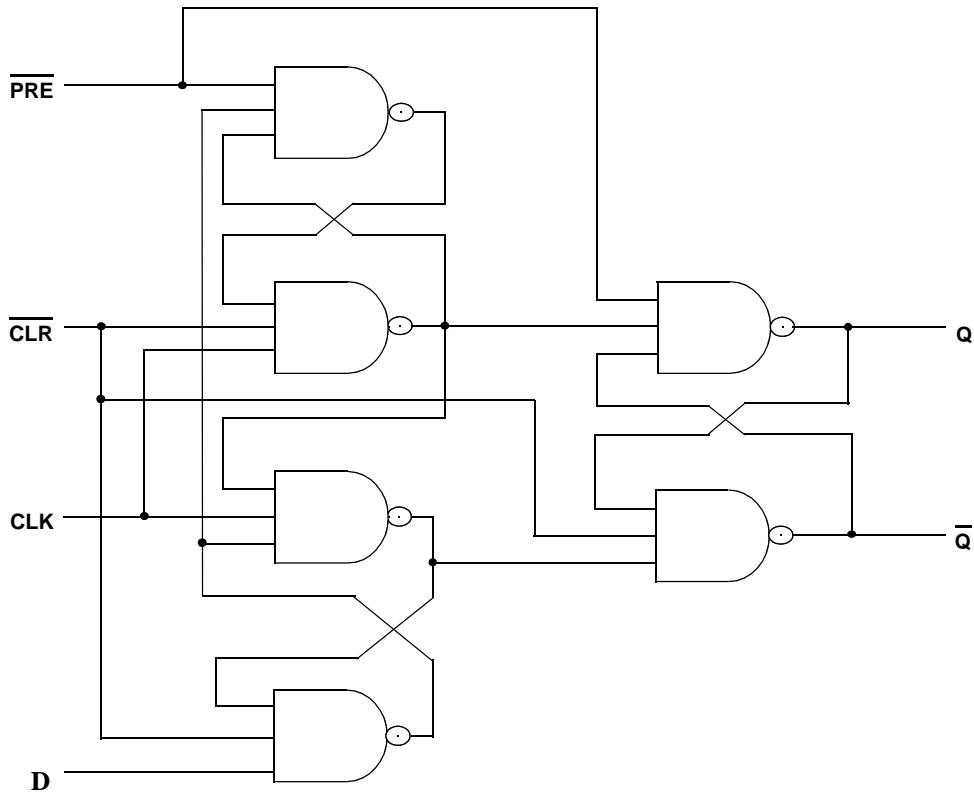

RADIATION HARDNESS SPECIFICATIONS ¹

PARAMETER	LIMIT	UNITS
Total Dose	1.0E6	rads(Si)
SEU Threshold ²	80	MeV-cm ² /mg
SEL Threshold	120	MeV-cm ² /mg
Neutron Fluence	1.0E14	n/cm ²

Notes:

1. Logic will not latchup during radiation exposure within the limits defined in the table.
2. Device storage elements are immune to SEU affects.

ABSOLUTE MAXIMUM RATINGS

SYMBOL	PARAMETER	LIMIT	UNITS
V _{DD}	Supply voltage	-0.3 to 7.0	V
V _{I/O}	Voltage any pin	-0.3 to V _{DD} +0.3	V
T _{STG}	Storage Temperature range	-65 to +150	°C
T _J	Maximum junction temperature	+175	°C
T _{LS}	Lead temperature (soldering 5 seconds)	+300	°C
Θ _{JC}	Thermal resistance junction to case	20	° C/W
I _I	DC input current	±10	mA
P _D	Maximum power dissipation	1	W

Note:

1. Stresses outside the listed absolute maximum ratings may cause permanent damage to the device. This is a stress rating only, functional operation of the device at these or any other conditions beyond limits indicated in the operational sections is not recommended. Exposure to absolute maximum rating conditions for extended periods may affect device reliability.

RECOMMENDED OPERATING CONDITIONS

SYMBOL	PARAMETER	LIMIT	UNITS
V _{DD}	Supply voltage	4.5 to 5.5	V
V _{IN}	Input voltage any pin	0 to V _{DD}	V
T _C	Temperature range	-55 to + 125	°C

DC ELECTRICAL CHARACTERISTICS ⁷(V_{DD} = 5.0V ±10%; V_{SS} = 0V ⁶, -55°C < T_C < +125°C)

SYMBOL	PARAMETER	CONDITION	MIN	MAX	UNIT
V _{IL}	Low-level input voltage ¹ ACTS ACS			0.8 0.3V _{DD}	V
V _{IH}	High-level input voltage ¹ ACTS ACS		0.5V _{DD} 0.7V _{DD}		V
I _{IN}	Input leakage current ACTS/ACS	V _{IN} = V _{DD} or V _{SS}	-1	1	μA
V _{OL}	Low-level output voltage ³ ACTS ACS	I _{OL} = 8.0mA I _{OL} = 100μA		0.40 0.25	V
V _{OH}	High-level output voltage ³ ACTS ACS	I _{OH} = -8.0mA I _{OH} = -100μA	0.7V _{DD} V _{DD} - 0.25		V
I _{OS}	Short-circuit output current ^{2,4} ACTS/ACS	V _O = V _{DD} and V _{SS}	-200	200	mA
I _{OL}	Output current ¹⁰ (Sink)	V _{IN} = V _{DD} or V _{SS} V _{OL} = 0.4V	8		mA
I _{OH}	Output current ¹⁰ (Source)	V _{IN} = V _{DD} or V _{SS} V _{OH} = V _{DD} - 0.4V	-8		mA
P _{total}	Power dissipation ^{2, 8, 9}	C _L = 50pF		1.9	mW/MHz
I _{DDQ}	Quiescent Supply Current	V _{DD} = 5.5V		10	μA
ΔI _{DDQ}	Quiescent Supply Current Delta ACTS	For input under test V _{IN} = V _{DD} - 2.1V For all other inputs V _{IN} = V _{DD} or V _{SS} V _{DD} = 5.5V		1.6	mA
C _{IN}	Input capacitance ⁵	f = 1MHz @ 0V		15	pF
C _{OUT}	Output capacitance ⁵	f = 1MHz @ 0V		15	pF

UT54ACS74/UT54ACTS74

Notes:

1. Functional tests are conducted in accordance with MIL-STD-883 with the following input test conditions: $V_{IH} = V_{IH(min)} + 20\%$, $- 0\%$; $V_{IL} = V_{IL(max)} + 0\%$, $- 50\%$, as specified herein, for TTL, CMOS, or Schmitt compatible inputs. Devices may be tested using any input voltage within the above specified range, but are guaranteed to $V_{IH(min)}$ and $V_{IL(max)}$.
2. Supplied as a design limit but not guaranteed or tested.
3. Per MIL-PRF-38535, for current density $\leq 5.0E5$ amps/cm², the maximum product of load capacitance (per output buffer) times frequency should not exceed 3,765 pF/MHz.
4. Not more than one output may be shorted at a time for maximum duration of one second.
5. Capacitance measured for initial qualification and when design changes may affect the value. Capacitance is measured between the designated terminal and V_{SS} at a frequency of 1MHz and a signal amplitude of 50mV rms maximum.
6. Maximum allowable relative shift equals 50mV.
7. All specifications valid for radiation dose $\leq 1E6$ rads(Si).
8. Power does not include power contribution of any TTL output sink current.
9. Power dissipation specified per switching output.
10. This value is guaranteed based on characterization data, but not tested.

AC ELECTRICAL CHARACTERISTICS ²(V_{DD} = 5.0V ±10%; V_{SS} = 0V ¹, -55°C < T_C < +125°C)

SYMBOL	PARAMETER	MINIMUM	MAXIMUM	UNIT
t _{PHL}	CLK to Q, \overline{Q}	3	21	ns
t _{PLH}	CLK to Q, \overline{Q}	1	20	ns
t _{PLH}	\overline{PRE} to Q	1	15	ns
t _{PHL}	\overline{PRE} to \overline{Q}	3	19	ns
t _{PHL}	\overline{CLR} to Q	3	19	ns
t _{PLH}	\overline{CLR} to \overline{Q}	1	15	ns
f _{MAX}	Maximum clock frequency		71	MHz
t _{SU1}	\overline{PRE} or \overline{CLR} inactive Setup time before CLK ↑	5		ns
t _{SU2}	Data setup time before CLK ↑	5		ns
t _H ³	Data hold time after CLK ↑	2		ns
t _W	Minimum pulse width \overline{PRE} or \overline{CLR} low CLK high CLK low	7		ns

Notes:

1. Maximum allowable relative shift equals 50mV.
2. All specifications valid for radiation dose ≤ 1E6 rads(Si).
3. Based on characterization, hold time (t_H) of 0ns can be assumed if data setup time (t_{SU2}) is ≥10ns. This is guaranteed, but not tested.

UT54ACS85/UT54ACTS85

Radiation-Hardened 4-Bit Comparators

FEATURES

- 1.2μ radiation-hardened CMOS
 - Latchup immune
- High speed
- Low power consumption
- Single 5 volt supply
- Available QML Q or V processes
- Flexible package
 - 16-pin DIP
 - 16-lead flatpack

DESCRIPTION

The UT54ACS85 and the UT54ACTS85 are 4-bit magnitude comparators that perform comparison of straight binary and straight BCD (8-4-2-1) codes. Three fully decoded decisions about two 4-bit words (A, B) are made and are externally available at three outputs. Devices are fully expandable to any number of bits without external gates. The cascading paths of the devices are implemented with only a two-gate-level delay to reduce overall comparison times for long words. An alternate method of cascading which further reduces the comparison time is shown in the typical application data.

The devices are characterized over full military temperature range of -55°C to +125°C.

LOGIC SYMBOL

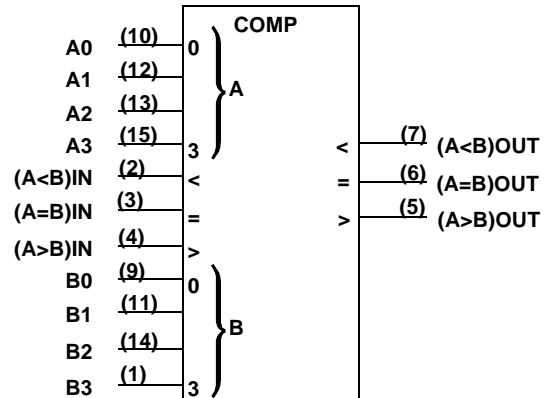

Note:

1. Logic symbol in accordance with ANSI/IEEE standard 91-1984 and IEC Publication 617-12.

PINOUTS

16-Pin DIP Top View

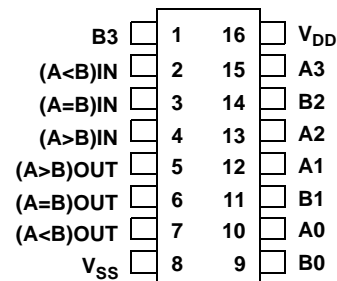

16-Lead Flatpack Top View

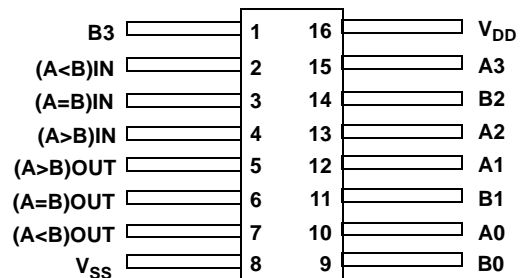

FUNCTION TABLE

COMPARING INPUTS				CASCADING INPUTS			OUTPUTS		
A3, B3	A2, B2	A1, B1	A0, B0	A>B	A<B	A=B	A>B	A<B	A=B
A3>B3	X	X	X	X	X	X	H	L	L
A3<B3	X	X	X	X	X	X	L	H	L
A3=B3	A2>B2	X	X	X	X	X	H	L	L
A3=B3	A2<B2	X	X	X	X	X	L	H	L
A3=B3	A2=B2	A1>B1	X	X	X	X	H	L	L
A3=B3	A2=B2	A1<B1	X	X	X	X	L	H	L
A3=B3	A2=B2	A1=B1	A0>B0	X	X	X	H	L	L
A3=B3	A2=B2	A1=B1	A0<B0	X	X	X	L	H	L
A3=B3	A2=B2	A1=B1	A0=B0	H	L	L	H	L	L
A3=B3	A2=B2	A1=B1	A0=B0	L	H	L	L	H	L
A3=B3	A2=B2	A1=B1	A0=B0	X	X	H	L	L	H
A3=B3	A2=B2	A1=B1	A0=B0	H	H	L	L	L	L
A3=B3	A2=B2	A1=B1	A0=B0	L	L	L	H	H	L

LOGIC DIAGRAM

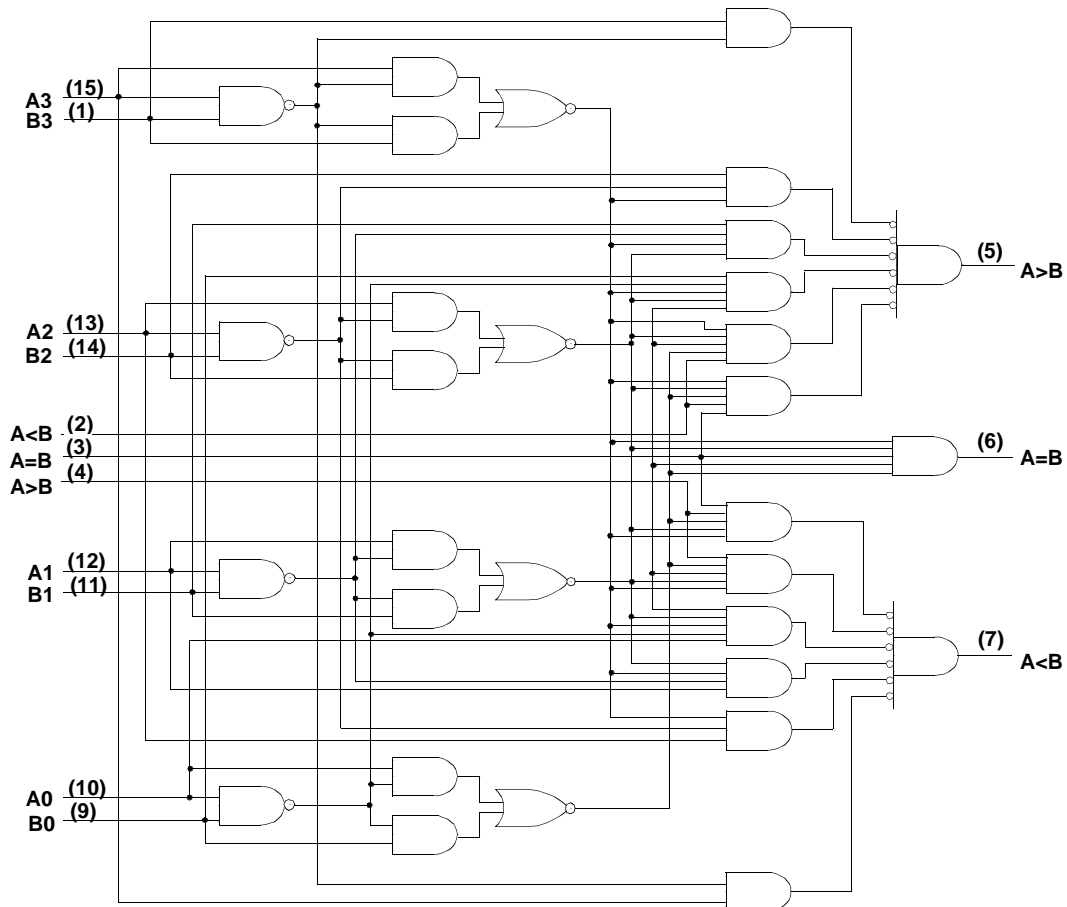

RADIATION HARDNESS SPECIFICATIONS ¹

PARAMETER	LIMIT	UNITS
Total Dose	1.0E6	rads(Si)
SEU Threshold ²	80	MeV-cm ² /mg
SEL Threshold	120	MeV-cm ² /mg
Neutron Fluence	1.0E14	n/cm ²

Notes:

1. Logic will not latchup during radiation exposure within the limits defined in the table.
2. Device storage elements are immune to SEU affects.

ABSOLUTE MAXIMUM RATINGS

SYMBOL	PARAMETER	LIMIT	UNITS
V _{DD}	Supply voltage	-0.3 to 7.0	V
V _{I/O}	Voltage any pin	-.3 to V _{DD} +.3	V
T _{STG}	Storage Temperature range	-65 to +150	°C
T _J	Maximum junction temperature	+175	°C
T _{LS}	Lead temperature (soldering 5 seconds)	+300	°C
Θ _{JC}	Thermal resistance junction to case	20	°C/W
I _I	DC input current	±10	mA
P _D	Maximum power dissipation	1	W

Note:

1. Stresses outside the listed absolute maximum ratings may cause permanent damage to the device. This is a stress rating only, functional operation of the device at these or any other conditions beyond limits indicated in the operational sections is not recommended. Exposure to absolute maximum rating conditions for extended periods may affect device reliability.

RECOMMENDED OPERATING CONDITIONS

SYMBOL	PARAMETER	LIMIT	UNITS
V _{DD}	Supply voltage	4.5 to 5.5	V
V _{IN}	Input voltage any pin	0 to V _{DD}	V
T _C	Temperature range	-55 to + 125	°C

DC ELECTRICAL CHARACTERISTICS ⁷(V_{DD} = 5.0V ±10%; V_{SS} = 0V ⁶, -55 °C < T_C < +125°C)

SYMBOL	PARAMETER	CONDITION	MIN	MAX	UNIT
V _{IL}	Low-level input voltage ¹ ACTS ACS			0.8 .3V _{DD}	V
V _{IH}	High-level input voltage ¹ ACTS ACS		.5V _{DD} .7V _{DD}		V
I _{IN}	Input leakage current ACTS/ACS	V _{IN} = V _{DD} or V _{SS}	-1	1	μA
V _{OL}	Low-level output voltage ³ ACTS ACS	I _{OL} = 8.0mA I _{OL} = 100μA		0.40 0.25	V
V _{OH}	High-level output voltage ³ ACTS ACS	I _{OH} = -8.0mA I _{OH} = -100μA	.7V _{DD} V _{DD} - 0.25		V
I _{OS}	Short-circuit output current ^{2,4} ACTS/ACS	V _O = V _{DD} and V _{SS}	-200	200	mA
I _{OL}	Output current ¹⁰ (Sink)	V _{IN} = V _{DD} or V _{SS} V _{OL} = 0.4V	8		mA
I _{OH}	Output current ¹⁰ (Source)	V _{IN} = V _{DD} or V _{SS} V _{OH} = V _{DD} - 0.4V	-8		mA
P _{total}	Power dissipation ^{2, 8, 9}	C _L = 50pF		2.3	mW/ MHz
I _{DDQ}	Quiescent Supply Current	V _{DD} = 5.5V		10	μA
ΔI _{DDQ}	Quiescent Supply Current Delta ACTS	For input under test V _{IN} = V _{DD} - 2.1V For all other inputs V _{IN} = V _{DD} or V _{SS} V _{DD} = 5.5V		1.6	mA
C _{IN}	Input capacitance ⁵	f = 1MHz @ 0V		15	pF
C _{OUT}	Output capacitance ⁵	f = 1MHz @ 0V		15	pF

UT54ACS85/UT54ACTS85

Notes:

1. Functional tests are conducted in accordance with MIL-STD-883 with the following input test conditions: $V_{IH} = V_{IH(min)} + 20\%$, $- 0\%$; $V_{IL} = V_{IL(max)} + 0\%$, $- 50\%$, as specified herein, for TTL, CMOS, or Schmitt compatible inputs. Devices may be tested using any input voltage within the above specified range, but are guaranteed to $V_{IH(min)}$ and $V_{IL(max)}$.
2. Supplied as a design limit but not guaranteed or tested.
3. Per MIL-PRF-38535, for current density $\leq 5.0E5$ amps/cm², the maximum product of load capacitance (per output buffer) times frequency should not exceed 3,765 pF/MHz.
4. Not more than one output may be shorted at a time for maximum duration of one second.
5. Capacitance measured for initial qualification and when design changes may affect the value. Capacitance is measured between the designated terminal and V_{SS} at frequency of 1MHz and a signal amplitude of 50mV rms maximum
7. All specifications valid for radiation dose $\leq 1E6$ rads(Si).
6. Maximum allowable relative shift equals 50mV.
8. Power does not include power contribution of any TTL output sink current.
9. Power dissipation specified per switching output.
10. This value is guaranteed based on characterization data, but not tested.

AC ELECTRICAL CHARACTERISTICS ² $(V_{DD} = 5.0V \pm 10\%; V_{SS} = 0V^1, -55^\circ C < T_C < +125^\circ C)$

SYMBOL	PARAMETER	MINIMUM	MAXIMUM	UNIT
t_{PHL}	An, Bn to (A<B) _{OUT}	2	22	ns
t_{PLH}	An, Bn to (A<B) _{OUT}	2	16	ns
t_{PHL}	An, Bn to (A=B) _{OUT}	2	17	ns
t_{PLH}	An, Bn to (A=B) _{OUT}	2	16	ns
t_{PHL}	An, Bn to (A>B) _{OUT}	2	18	ns
t_{PLH}	An, Bn to (A>B) _{OUT}	2	16	ns
t_{PHL}	(A<B) _{IN} , (A=B) _{IN} to (A>B) _{OUT}	2	17	ns
t_{PLH}	(A<B) _{IN} , (A=B) _{IN} to (A>B) _{OUT}	2	15	ns
t_{PHL}	(A=B) _{IN} to (A=B) _{OUT}	2	13	ns
t_{PLH}	(A=B) _{IN} to (A=B) _{OUT}	1	15	ns
t_{PHL}	(A>B) _{IN} , (A=B) _{IN} to (A<B) _{OUT}	2	17	ns
t_{PLH}	(A>B) _{IN} , (A=B) _{IN} to (A<B) _{OUT}	2	15	ns

Notes:

1. Maximum allowable relative shift equals 50mV.
2. All specifications valid for radiation dose $\leq 1E6$ rads(Si)

UT54ACS86/UT54ACTS86

Radiation-Hardened Quadruple 2-Input Exclusive OR Gates

FEATURES

- 1.2μ radiation-hardened CMOS
 - Latchup immune
- High speed
- Low power consumption
- Single 5 volt supply
- Available QML Q or V processes
- Flexible package
 - 14-pin DIP
 - 14-lead flatpack

DESCRIPTION

The UT54ACS86 and the UT54ACTS86 are quadruple 2-input exclusive OR gates. The devices perform the Boolean function $Y = A \oplus B = \overline{A}B + A\overline{B}$ in positive logic.

An application is as a true/complement element. If one of the inputs is low, the other input will be reproduced in true form at the output. If one of the inputs is high, the signal on the other input will be reproduced inverted at the output.

The devices are characterized over full military temperature range of -55°C to +125°C.

FUNCTION TABLE

INPUTS		OUTPUT
A	B	Y
L	L	L
L	H	H
H	L	H
H	H	L

LOGIC SYMBOL

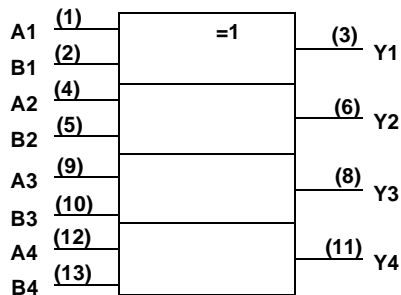

Note:

1. Logic symbol in accordance with ANSI/IEEE standard 91-1984 and IEC Publication 617-12.

PINOUTS

14-Pin DIP Top View

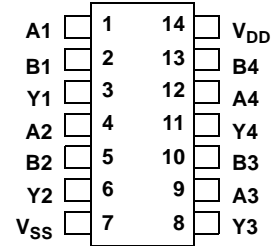

14-Lead Flatpack Top View

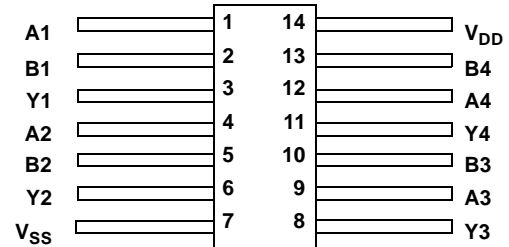

LOGIC DIAGRAM

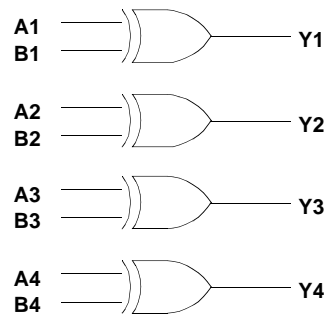

RADIATION HARDNESS SPECIFICATIONS ¹

PARAMETER	LIMIT	UNITS
Total Dose	1.0E6	rads(Si)
SEU Threshold ²	80	MeV-cm ² /mg
SEL Threshold	120	MeV-cm ² /mg
Neutron Fluence	1.0E14	n/cm ²

Notes:

1. Logic will not latchup during radiation exposure within the limits defined in the table.
2. Device storage elements are immune to SEU affects.

ABSOLUTE MAXIMUM RATINGS

SYMBOL	PARAMETER	LIMIT	UNITS
V _{DD}	Supply voltage	-0.3 to 7.0	V
V _{I/O}	Voltage any pin	-.3 to V _{DD} +.3	V
T _{STG}	Storage Temperature range	-65 to +150	°C
T _J	Maximum junction temperature	+175	°C
T _{LS}	Lead temperature (soldering 5 seconds)	+300	°C
Θ _{JC}	Thermal resistance junction to case	20	°C/W
I _I	DC input current	±10	mA
P _D	Maximum power dissipation	1	W

Note:

1. Stresses outside the listed absolute maximum ratings may cause permanent damage to the device. This is a stress rating only, functional operation of the device at these or any other conditions beyond limits indicated in the operational sections is not recommended. Exposure to absolute maximum rating conditions for extended periods may affect device reliability.

RECOMMENDED OPERATING CONDITIONS

SYMBOL	PARAMETER	LIMIT	UNITS
V _{DD}	Supply voltage	4.5 to 5.5	V
V _{IN}	Input voltage any pin	0 to V _{DD}	V
T _C	Temperature range	-55 to + 125	°C

DC ELECTRICAL CHARACTERISTICS ⁷

($V_{DD} = 5.0V \pm 10\%$; $V_{SS} = 0V$ ⁶, $-55^{\circ}C < T_C < +125^{\circ}C$)

SYMBOL	PARAMETER	CONDITION	MIN	MAX	UNIT
V_{IL}	Low-level input voltage ¹ ACTS ACS			0.8 .3 V_{DD}	V
V_{IH}	High-level input voltage ¹ ACTS ACS		.5 V_{DD} .7 V_{DD}		V
I_{IN}	Input leakage current ACTS/ACS	$V_{IN} = V_{DD}$ or V_{SS}	-1	1	μA
V_{OL}	Low-level output voltage ³ ACTS ACS	$I_{OL} = 8.0mA$ $I_{OL} = 100\mu A$		0.40 0.25	V
V_{OH}	High-level output voltage ³ ACTS ACS	$I_{OH} = -8.0mA$ $I_{OH} = -100\mu A$.7 V_{DD} $V_{DD} - 0.25$		V
I_{OS}	Short-circuit output current ^{2,4} ACTS/ACS	$V_O = V_{DD}$ and V_{SS}	-200	200	mA
I_{OL}	Output current ¹⁰ (Sink)	$V_{IN} = V_{DD}$ or V_{SS} $V_{OL} = 0.4V$	8		mA
I_{OH}	Output current ¹⁰ (Source)	$V_{IN} = V_{DD}$ or V_{SS} $V_{OH} = V_{DD} - 0.4V$	-8		mA
P_{total}	Power dissipation ^{2, 8, 9}	$C_L = 50pF$		1.8	mW/ MHz
I_{DDQ}	Quiescent Supply Current	$V_{DD} = 5.5V$		10	μA
ΔI_{DDQ}	Quiescent Supply Current Delta ACTS	For input under test $V_{IN} = V_{DD} - 2.1V$ For all other inputs $V_{IN} = V_{DD}$ or V_{SS} $V_{DD} = 5.5V$		1.6	mA
C_{IN}	Input capacitance ⁵	$f = 1MHz @ 0V$		15	pF
C_{OUT}	Output capacitance ⁵	$f = 1MHz @ 0V$		15	pF

Notes:

1. Functional tests are conducted in accordance with MIL-STD-883 with the following input test conditions: $V_{IH} = V_{IH(min)} + 20\%$, $- 0\%$; $V_{IL} = V_{IL(max)} + 0\%$, $- 50\%$, as specified herein, for TTL, CMOS, or Schmitt compatible inputs. Devices may be tested using any input voltage within the above specified range, but are guaranteed to $V_{IH(min)}$ and $V_{IL(max)}$.
2. Supplied as a design limit but not guaranteed or tested.
3. Per MIL-PRF-38535, for current density $\leq 5.0E5$ amps/cm², the maximum product of load capacitance (per output buffer) times frequency should not exceed 3,765 pF/MHz.
4. Not more than one output may be shorted at a time for maximum duration of one second.
5. Capacitance measured for initial qualification and when design changes may affect the value. Capacitance is measured between the designated terminal and V_{SS} at frequency of 1MHz and a signal amplitude of 50mV rms maximum.
6. Maximum allowable relative shift equals 50mV.
7. All specifications valid for radiation dose $\leq 1E6$ rads(Si).
8. Power does not include power contribution of any TTL output sink current.
9. Power dissipation specified per switching output.
10. This value is guaranteed based on characterization data, but not tested.

AC ELECTRICAL CHARACTERISTICS ²

($V_{DD} = 5.0V \pm 10\%$; $V_{SS} = 0V$ ¹, $-55^{\circ}C < T_C < +125^{\circ}C$)

SYMBOL	PARAMETER	MINIMUM	MAXIMUM	UNIT
t _{PHL}	Data to input	1	14	ns
t _{PLH}	Data to input	1	13	ns

Notes:

1. Maximum allowable relative shift equals 50mV.
2. All specifications valid for radiation dose $\leq 1E6$ rads(Si).

UT54ACS109/UT54ACTS109

Radiation-Hardened Dual J-K Flip-Flops

Dec. 1, 2003

FEATURES

- 1.2 μ radiation-hardened CMOS (ACTS109) and 0.6 μ CRH CMOS process (ACS109)
 - Latchup immune
- High speed
- Low power consumption
- Single 5 volt supply
- Available QML Q or V processes
- Flexible package
 - 16-pin DIP (not available for ACS109)
 - 16-lead flatpack

DESCRIPTION

The UT54ACS109 and the UT54ACTS109 are dual J- \bar{K} positive triggered flip-flops. A low level at the preset or clear inputs sets or resets the outputs regardless of the other input levels. When preset and clear are inactive (high), data at the J and \bar{K} input meeting the setup time requirements are transferred to the outputs on the positive-going edge of the clock pulse. Following the hold time interval, data at the J and \bar{K} input can be changed without affecting the levels at the outputs. The flip-flops can perform as toggle flip-flops by grounding \bar{K} and tying J high. They also can perform as D flip-flops if J and \bar{K} are tied together.

The devices are characterized over full military temperature range of -55°C to +125°C.

FUNCTION TABLE

INPUTS					OUTPUT	
\bar{PRE}	\bar{CLR}	CLK	J	\bar{K}	Q	\bar{Q}
L	H	X	X	X	H	L
H	L	X	X	X	L	H
L	L	X	X	X	H ¹	H ¹
H	H	↑	L	L	L	H
H	H	↑	H	L	Toggle	
H	H	↑	L	H	No Change	
H	H	↑	H	H	H	L
H	H	L	X	X	No Change	

Note:

1. The output levels in this configuration are not guaranteed to meet the minimum levels for V_{OH} if the lows at preset and clear are near V_{IL} maximum. In

addition, this configuration is nonstable; that is, it will not persist when either preset or clear returns to its inactive (high) level.

PINOUTS

16-Pin DIP Top View

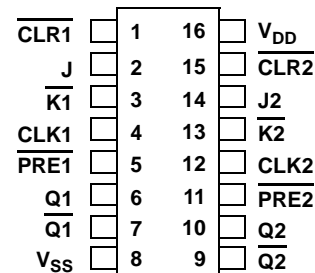

16-Lead Flatpack Top View

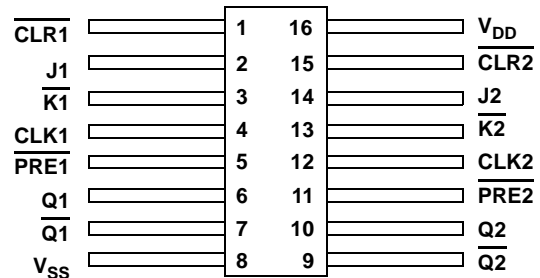

LOGIC SYMBOL

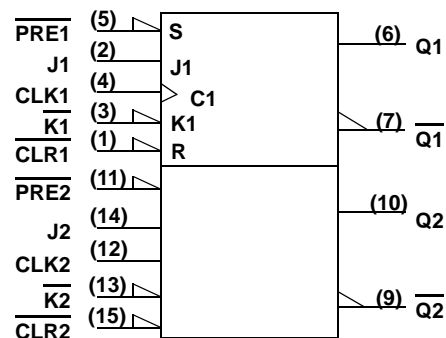

Note:

1. Logic symbol in accordance with ANSI/IEEE standard 91-1984 and IEC Publication 617-12.

LOGIC DIAGRAM

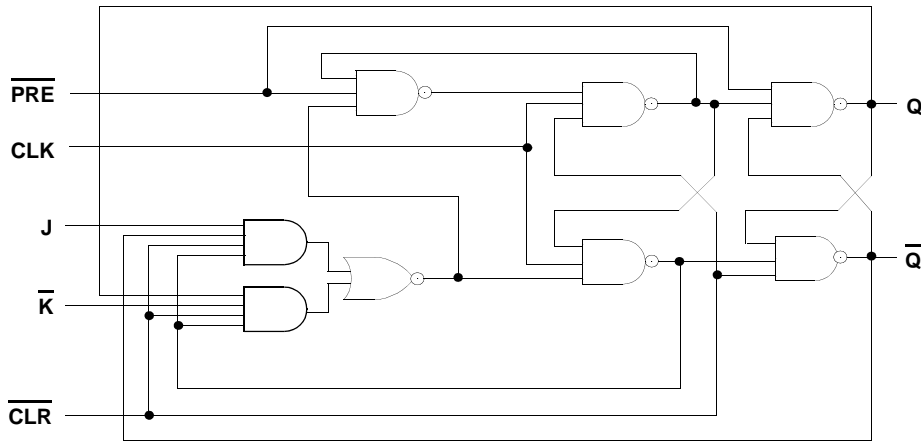

RADIATION HARDNESS SPECIFICATIONS ¹

PARAMETER	LIMIT	UNITS
Total Dose	1.0E6 (ACTS109) 5.0E5 (ACS109)	rads(Si)
SEU Threshold ²	80	MeV-cm ² /mg
SEL Threshold	120	MeV-cm ² /mg
Neutron Fluence	1.0E14	n/cm ²

Notes:

1. Logic will not latchup during radiation exposure within the limits defined in the table.
2. Device storage elements are immune to SEU affects.

ABSOLUTE MAXIMUM RATINGS

SYMBOL	PARAMETER	LIMIT	UNITS
V _{DD}	Supply voltage	-0.3 to 7.0	V
V _{I/O}	Voltage any pin	-.3 to V _{DD} +.3	V
T _{STG}	Storage Temperature range	-65 to +150	°C
T _J	Maximum junction temperature	+175	°C
T _{LS}	Lead temperature (soldering 5 seconds)	+300	°C
Θ _{JC}	Thermal resistance junction to case	20	°C/W
I _I	DC input current	±10	mA
P _D	Maximum power dissipation	1	W

Note:

1. Stresses outside the listed absolute maximum ratings may cause permanent damage to the device. This is a stress rating only, functional operation of the device at these or any other conditions beyond limits indicated in the operational sections is not recommended. Exposure to absolute maximum rating conditions for extended periods may affect device reliability.

RECOMMENDED OPERATING CONDITIONS

SYMBOL	PARAMETER	LIMIT	UNITS
V_{DD}	Supply voltage	4.5 to 5.5	V
V_{IN}	Input voltage any pin	0 to V_{DD}	V
T_C	Temperature range	-55 to + 125	°C

DC ELECTRICAL CHARACTERISTICS ⁷(V_{DD} = 5.0V ±10%; V_{SS} = 0V ⁶, -55°C < T_C < +125°C)

SYMBOL	PARAMETER	CONDITION	MIN	MAX	UNIT
V _{IL}	Low-level input voltage ¹ ACTS ACS			0.8 .3V _{DD}	V
V _{IH}	High-level input voltage ¹ ACTS ACS		.5V _{DD} .7V _{DD}		V
I _{IN}	Input leakage current ACTS/ACS	V _{IN} = V _{DD} or V _{SS}	-1	1	μA
V _{OL}	Low-level output voltage ³ ACTS ACS	I _{OL} = 8.0mA I _{OL} = 100μA		0.40 0.25	V
V _{OH}	High-level output voltage ³ ACTS ACS	I _{OH} = -8.0mA I _{OH} = -100μA	.7V _{DD} V _{DD} - 0.25		V
I _{OS}	Short-circuit output current ^{2,4} ACTS/ACS	V _O = V _{DD} and V _{SS}	-200	200	mA
I _{OL}	Output current ¹⁰ (Sink)	V _{IN} = V _{DD} or V _{SS} V _{OL} = 0.4V	8		mA
I _{OH}	Output current ¹⁰ (Source)	V _{IN} = V _{DD} or V _{SS} V _{OH} = V _{DD} - 0.4V	-8		mA
P _{total}	Power dissipation ^{2, 8,9}	C _L = 50pF		2.0	mW/ MHz
I _{DDQ}	Quiescent Supply Current	V _{DD} = 5.5V		10	μA
ΔI _{DDQ}	Quiescent Supply Current Delta ACTS	For input under test V _{IN} = V _{DD} - 2.1V For all other inputs V _{IN} = V _{DD} or V _{SS} V _{DD} = 5.5V		1.6	mA
C _{IN}	Input capacitance ⁵	f = 1MHz @ 0V		15	pF
C _{OUT}	Output capacitance ⁵	f = 1MHz @ 0V		15	pF

UT54ACS109/UT54ACTS109

Notes:

1. Functional tests are conducted in accordance with MIL-STD-883 with the following input test conditions: $V_{IH} = V_{IH(min)} + 20\%$, $- 0\%$; $V_{IL} = V_{IL(max)} + 0\%$, $- 50\%$, as specified herein, for TTL, CMOS, or Schmitt compatible inputs. Devices may be tested using any input voltage within the above specified range, but are guaranteed to $V_{IH(min)}$ and $V_{IL(max)}$.
2. Supplied as a design limit but not guaranteed or tested.
3. Per MIL-PRF-38535, for current density $\leq 5.0E5$ amps/cm², the maximum product of load capacitance (per output buffer) times frequency should not exceed 3,765 pF/MHz.
4. Not more than one output may be shorted at a time for maximum duration of one second.
5. Capacitance measured for initial qualification and when design changes may affect the value. Capacitance is measured between the designated terminal and V_{SS} at frequency of 1MHz and a signal amplitude of 50mV rms maximum.
6. Maximum allowable relative shift equals 50mV.
7. All ACTS specifications are valid for radiation dose $\leq 1E6$ rads(Si), and all ACS specifications are valid for radiation dose $\leq 5E5$ rads(Si).
8. Power does not include power contribution of any TTL output sink current.
9. Power dissipation specified per switching output.
10. This value is guaranteed based on characterization data, but not tested.

AC ELECTRICAL CHARACTERISTICS ²(V_{DD} = 5.0V ±10%; V_{SS} = 0V ¹, -55°C < T_C < +125°C)

SYMBOL	PARAMETER	MINIMUM	MAXIMUM	UNIT
t _{PHL}	CLK to Q, \overline{Q}	5	27	ns
t _{PLH}	CLK to Q, \overline{Q}	4	23	ns
t _{PLH}	\overline{PRE} to Q	1	16	ns
t _{PHL}	\overline{PRE} to \overline{Q}	1	19	ns
t _{PHL}	\overline{CLR} to Q	2	19	ns
t _{PLH}	\overline{CLR} to \overline{Q}	2	16	ns
f _{MAX}	Maximum clock frequency		62	MHz
t _{SU1}	\overline{PRE} or \overline{CLR} inactive Setup time before CLK ↑	5		ns
t _{SU2}	Data setup time before CLK ↑	5		ns
t _H ³	Data hold time after CLK ↑	3		ns
t _W	Minimum pulse width \overline{PRE} or \overline{CLR} low CLK high CLK low	8		ns

Notes:

1. Maximum allowable relative shift equals 50mV.
2. For the ACTS version, all specifications are valid for radiation dose ≤1E6 rads(Si). For the ACS version, all specifications are valid for radiation dose ≤5E5 rads(Si).
3. Based on characterization, hold time (t_H) of 0ns can be assumed if data setup time (t_{SU2}) is ≥10ns. This is guaranteed, but not tested.

UT54ACS132/UT54ACTS132

Radiation-Hardened

Quadruple 2-Input NAND Schmitt Triggers

Dec. 1, 2003

FEATURES

- 1.2 μ radiation-hardened CMOS (ACTS 132) and 0.6 μ CRH CMOS process (ACS132)
 - Latchup immune
- High speed
- Low power consumption
- Single 5 volt supply
- Available QML Q or V processes
- Flexible package
 - 14-pin DIP (not available for the ACS132)
 - 14-lead flatpack

DESCRIPTION

The UT54ACS132 and the UT54ACTS132 are 2-input NAND gates with Schmitt Trigger input levels. A high applied on both the inputs forces the output to a low state.

The devices are characterized over full military temperature range of -55°C to +125°C.

FUNCTION TABLE

INPUTS		OUTPUT
A _n	B _n	Y _n
L	L	H
L	H	H
H	L	H
H	H	L

LOGIC SYMBOL

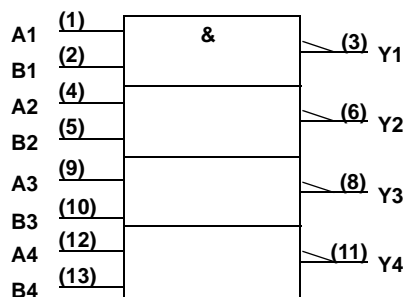

Note:

1. Logic symbol in accordance with ANSI/IEEE standard 91-1984 and IEC Publication 617-12.

PINOUTS

14-Pin DIP Top View

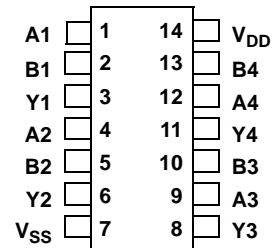

14-Lead Flatpack Top View

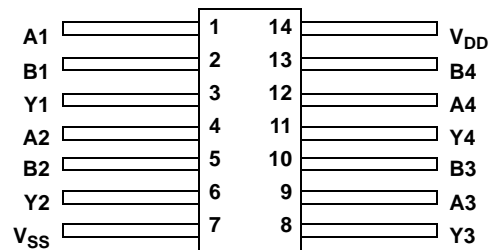

LOGIC DIAGRAM

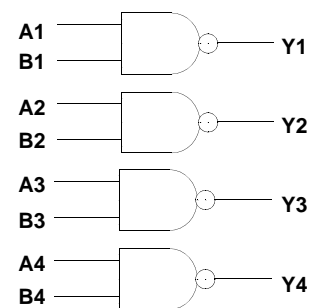

RADIATION HARDNESS SPECIFICATIONS ¹

PARAMETER	LIMIT	UNITS
Total Dose	1.0E6 (ACTS132) 5.0E5 (ACS132)	rads(Si)
SEU Threshold ²	80	MeV-cm ² /mg
SEL Threshold	120	MeV-cm ² /mg
Neutron Fluence	1.0E14	n/cm ²

Notes:

- Logic will not latchup during radiation exposure within the limits defined in the table.
- Device storage elements are immune to SEU affects.

ABSOLUTE MAXIMUM RATINGS

SYMBOL	PARAMETER	LIMIT	UNITS
V _{DD}	Supply voltage	-0.3 to 7.0	V
V _{I/O}	Voltage any pin	-.3 to V _{DD} +.3	V
T _{STG}	Storage Temperature range	-65 to +150	°C
T _J	Maximum junction temperature	+175	°C
T _{LS}	Lead temperature (soldering 5 seconds)	+300	°C
Θ _{JC}	Thermal resistance junction to case	20	°C/W
I _I	DC input current	±10	mA
P _D	Maximum power dissipation	1	W

Note:

- Stresses outside the listed absolute maximum ratings may cause permanent damage to the device. This is a stress rating only, functional operation of the device at these or any other conditions beyond limits indicated in the operational sections is not recommended. Exposure to absolute maximum rating conditions for extended periods may affect device reliability.

RECOMMENDED OPERATING CONDITIONS

SYMBOL	PARAMETER	LIMIT	UNITS
V _{DD}	Supply voltage	4.5 to 5.5	V
V _{IN}	Input voltage any pin	0 to V _{DD}	V
T _C	Temperature range	-55 to + 125	°C

DC ELECTRICAL CHARACTERISTICS ⁷

 ($V_{DD} = 5.0V \pm 10\%$; $V_{SS} = 0V$ ⁶, $-55^{\circ}C < T_C < +125^{\circ}C$)

SYMBOL	PARAMETER	CONDITION	MIN	MAX	UNIT
V_{T+}	Schmitt Trigger, positive going ¹ threshold ACTS ACS			2.25 .7 V_{DD}	V
V_{T-}	Schmitt Trigger, negative going ¹ threshold ACTS ACS		0.5 .3 V_{DD}		V
V_H	Schmitt Trigger, typical range of hysteresis ² ACTS ACS		0.3 0.6	0.9 1.5	V
I_{IN}	Input leakage current ACTS/ACS	$V_{IN} = V_{DD}$ or V_{SS}	-1	1	μA
V_{OL}	Low-level output voltage ³ ACTS ACS	$I_{OL} = 8.0mA$ $I_{OL} = 100\mu A$		0.40 0.25	V
V_{OH}	High-level output voltage ³ ACTS ACS	$I_{OH} = -8.0mA$ $I_{OH} = -100\mu A$.7 V_{DD} $V_{DD} - 0.25$		V
I_{OS}	Short-circuit output current ^{2,4} ACTS/ACS	$V_O = V_{DD}$ and V_{SS}	-200	200	mA
I_{OL}	Output current ¹⁰ (Sink)	$V_{IN} = V_{DD}$ or V_{SS} $V_{OL} = 0.4V$	8		mA
I_{OH}	Output current ¹⁰ (Source)	$V_{IN} = V_{DD}$ or V_{SS} $V_{OH} = V_{DD} - 0.4V$	-8		mA
P_{total}	Power dissipation ^{2, 8, 9}	$C_L = 50pF$		1.9	mW/ MHz
I_{DDQ}	Quiescent Supply Current	$V_{DD} = 5.5V$		10	μA
ΔI_{DDQ}	Quiescent Supply Current Delta ACTS	For input under test $V_{IN} = V_{DD} - 2.1V$ For all other inputs $V_{IN} = V_{DD}$ or V_{SS} $V_{DD} = 5.5V$		3.1	mA
C_{IN}	Input capacitance ⁵	$f = 1MHz @ 0V$		15	pF
C_{OUT}	Output capacitance ⁵	$f = 1MHz @ 0V$		15	pF

Notes:

1. Functional tests are conducted in accordance with MIL-STD-883 with the following input test conditions: $V_{IH} = V_{IH(min)} + 20\%$, $- 0\%$; $V_{IL} = V_{IL(max)} + 0\%$, $- 50\%$, as specified herein, for TTL, CMOS, or Schmitt compatible inputs. Devices may be tested using any input voltage within the above specified range, but are guaranteed to $V_{IH(min)}$ and $V_{IL(max)}$.
2. Supplied as a design limit but not guaranteed or tested.
3. Per MIL-PRF-38535, for current density $\leq 5.0E5$ amps/cm², the maximum product of load capacitance (per output buffer) times frequency should not exceed 3,765 pF/MHz.
4. Not more than one output may be shorted at a time for maximum duration of one second.
5. Capacitance measured for initial qualification and when design changes may affect the value. Capacitance is measured between the designated terminal and V_{SS} at frequency of 1MHz and a signal amplitude of 50mV rms maximum.
6. Maximum allowable relative shift equals 50mV.
7. All ACTS specifications are valid for radiation dose $\leq 1E6$ rads(Si), and all ACS specifications are valid for radiation dose $\leq 5E5$ rads(Si).
8. Power does not include power contribution of any TTL output sink current.
9. Power dissipation specified per switching output.
10. This value is guaranteed based on characterization data, but not tested.

AC ELECTRICAL CHARACTERISTICS ²

($V_{DD} = 5.0V \pm 10\%$; $V_{SS} = 0V$ ¹, $-55^{\circ}C < T_C < +125^{\circ}C$)

SYMBOL	PARAMETER	MINIMUM	MAXIMUM	UNIT
t_{PHL}	Input to Yn	2	15	ns
t_{PLH}	Input to Yn	2	12	ns

Notes:

1. Maximum allowable relative shift equals 50mV.
2. For the ACTS version, all specifications are valid for radiation dose $\leq 1E6$ rads(Si). For the ACS version, all specifications are valid for radiation dose $\leq 5E5$ rads(Si).

UT54ACS138/UT54ACTS138

Radiation-Hardened

3-Line to 8-Line Decoders/Demultiplexers

FEATURES

- 1.2μ radiation-hardened CMOS
 - Latchup immune
- High speed
- Low power consumption
- Single 5 volt supply
- Available QML Q or V processes
- Flexible package
 - 16-pin DIP
 - 16-lead flatpack

DESCRIPTION

The UT54ACS138 and the UT54ACTS138 3-line to 8-line decoders/demultiplexers are designed to be used in high-performance memory-decoding or data-routing applications requiring very short propagation delay times.

The conditions at the binary select inputs and the three enable inputs select one of eight output lines. Two active-low and one active-high enable inputs reduce the need for external gates of inverters when expanding. A 24-line decoder can be implemented without external inverters and a 32-line decoder requires only one inverter. An enable input can be used as a data input for demultiplexing applications.

The devices are characterized over full military temperature range of -55°C to +125°C.

PINOUTS

**16-Pin DIP
Top View**

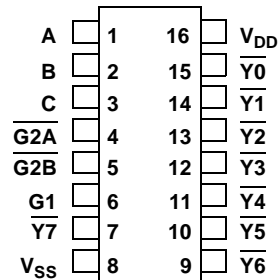

**16-Lead Flatpack
Top View**

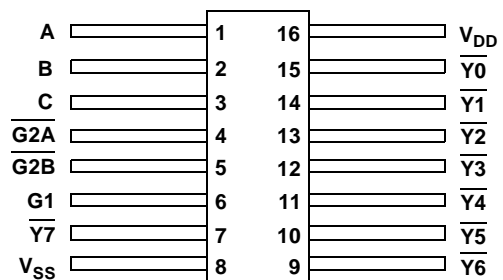

FUNCTION TABLE

ENABLE INPUTS			SELECT INPUTS			OUTPUT							
G1	$\overline{G2A}$	$\overline{G2B}$	C	B	A	$\overline{Y0}$	$\overline{Y1}$	$\overline{Y2}$	$\overline{Y3}$	$\overline{Y4}$	$\overline{Y5}$	$\overline{Y6}$	$\overline{Y7}$
X	X	H	X	X	X	H	H	H	H	H	H	H	H
L	X	X	X	X	X	H	H	H	H	H	H	H	H
X	H	X	X	X	X	H	H	H	H	H	H	H	H
H	L	L	L	L	L	L	H	H	H	H	H	H	H
H	L	L	L	L	H	H	L	H	H	H	H	H	H
H	L	L	L	H	L	H	H	L	H	H	H	H	H
H	L	L	H	L	L	H	H	H	H	L	H	H	H
H	L	L	H	L	H	H	H	H	H	H	L	H	H
H	L	L	H	H	L	H	H	H	H	H	H	L	H
H	L	L	H	H	H	H	H	H	H	H	H	H	L

LOGIC SYMBOL

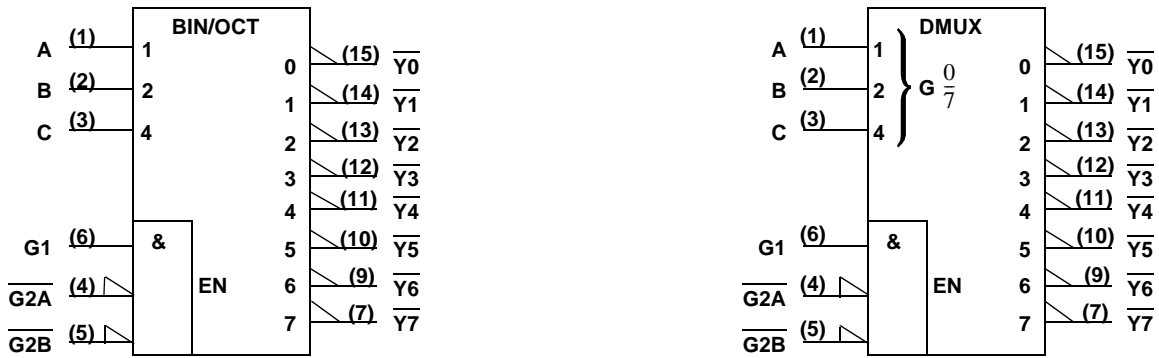

Note:

1. Logic symbols in accordance with ANSI/IEEE standard 91-1984 and IEC Publication 617-12.

LOGIC DIAGRAM

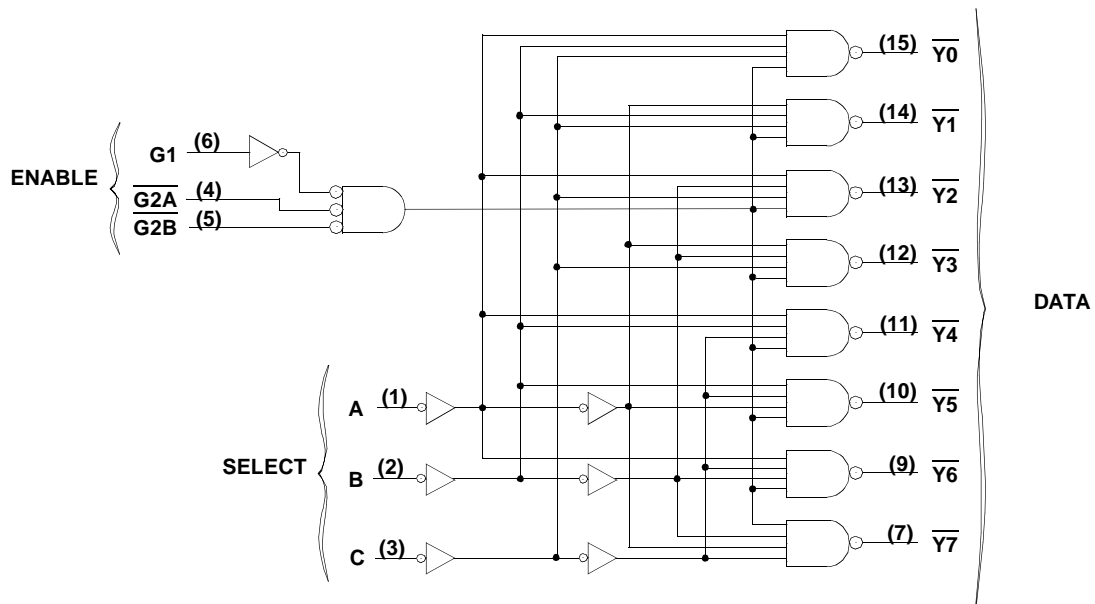

RADIATION HARDNESS SPECIFICATIONS ¹

PARAMETER	LIMIT	UNITS
Total Dose	1.0E6	rads(Si)
SEU Threshold ²	80	MeV-cm ² /mg
SEL Threshold	120	MeV-cm ² /mg
Neutron Fluence	1.0E14	n/cm ²

Notes:

1. Logic will not latchup during radiation exposure within the limits defined in the table.
2. Device storage elements are immune to SEU affects.

ABSOLUTE MAXIMUM RATINGS

SYMBOL	PARAMETER	LIMIT	UNITS
V _{DD}	Supply voltage	-0.3 to 7.0	V
V _{I/O}	Voltage any pin	-.3 to V _{DD} +.3	V
T _{STG}	Storage Temperature range	-65 to +150	°C
T _J	Maximum junction temperature	+175	°C
T _{LS}	Lead temperature (soldering 5 seconds)	+300	°C
Θ _{JC}	Thermal resistance junction to case	20	°C/W
I _I	DC input current	±10	mA
P _D	Maximum power dissipation	1	W

Note:

1. Stresses outside the listed absolute maximum ratings may cause permanent damage to the device. This is a stress rating only, functional operation of the device at these or any other conditions beyond limits indicated in the operational sections is not recommended. Exposure to absolute maximum rating conditions for extended periods may affect device reliability.

RECOMMENDED OPERATING CONDITIONS

SYMBOL	PARAMETER	LIMIT	UNITS
V _{DD}	Supply voltage	4.5 to 5.5	V
V _{IN}	Input voltage any pin	0 to V _{DD}	V
T _C	Temperature range	-55 to + 125	°C

DC ELECTRICAL CHARACTERISTICS ⁷ $(V_{DD} = 5.0V \pm 10\%; V_{SS} = 0V^6, -55^\circ C < T_C < +125^\circ C)$

SYMBOL	PARAMETER	CONDITION	MIN	MAX	UNIT
V_{IL}	Low-level input voltage ¹ ACTS ACS			0.8 .3 V_{DD}	V
V_{IH}	High-level input voltage ¹ ACTS ACS		.5 V_{DD} .7 V_{DD}		V
I_{IN}	Input leakage current ACTS/ACS	$V_{IN} = V_{DD}$ or V_{SS}	-1	1	μA
V_{OL}	Low-level output voltage ³ ACTS ACS	$I_{OL} = 8.0mA$ $I_{OL} = 100\mu A$		0.40 0.25	V
V_{OH}	High-level output voltage ³ ACTS ACS	$I_{OH} = -8.0mA$ $I_{OH} = -100\mu A$.7 V_{DD} $V_{DD} - 0.25$		V
I_{OS}	Short-circuit output current ^{2,4} ACTS/ACS	$V_O = V_{DD}$ and V_{SS}	-200	200	mA
I_{OL}	Output current ¹⁰ (Sink)	$V_{IN} = V_{DD}$ or V_{SS} $V_{OL} = 0.4V$	8		mA
I_{OH}	Output current ¹⁰ (Source)	$V_{IN} = V_{DD}$ or V_{SS} $V_{OH} = V_{DD} - 0.4V$	-8		mA
P_{total}	Power dissipation ^{2,8,9}	$C_L = 50pF$		1.9	mW/ MHz
I_{DDQ}	Quiescent Supply Current	$V_{DD} = 5.5V$		10	μA
ΔI_{DDQ}	Quiescent Supply Current Delta ACTS	For input under test $V_{IN} = V_{DD} - 2.1V$ For all other inputs $V_{IN} = V_{DD}$ or V_{SS} $V_{DD} = 5.5V$		1.6	mA
C_{IN}	Input capacitance ⁵	$f = 1MHz @ 0V$		15	pF
C_{OUT}	Output capacitance ⁵	$f = 1MHz @ 0V$		15	pF

UT54ACS138/UT54ACTS138

Notes:

1. Functional tests are conducted in accordance with MIL-STD-883 with the following input test conditions: $V_{IH} = V_{IH(min)} + 20\%$, $- 0\%$; $V_{IL} = V_{IL(max)} + 0\%$, $- 50\%$, as specified herein, for TTL, CMOS, or Schmitt compatible inputs. Devices may be tested using any input voltage within the above specified range, but are guaranteed to $V_{IH(min)}$ and $V_{IL(max)}$.
2. Supplied as a design limit but not guaranteed or tested.
3. Per MIL-PRF-38535, for current density $\leq 5.0E5$ amps/cm², the maximum product of load capacitance (per output buffer) times frequency should not exceed 3,765 pF/MHz.
4. Not more than one output may be shorted at a time for maximum duration of one second.
5. Capacitance measured for initial qualification and when design changes may affect the value. Capacitance is measured between the designated terminal and V_{SS} at frequency of 1MHz and a signal amplitude of 50mV rms maximum.
6. Maximum allowable relative shift equals 50mV.
7. All specifications valid for radiation dose $\leq 1E6$ rads(Si).
8. Power does not include power contribution of any TTL output sink current.
9. Power dissipation specified per switching output.
10. This value is guaranteed based on characterization data, but not tested.

AC ELECTRICAL CHARACTERISTICS ²(V_{DD} = 5.0V ±10%; V_{SS} = 0V ¹, -55°C < T_C < +125°C)

SYMBOL	PARAMETER	MINIMUM	MAXIMUM	UNIT
t _{PHL}	Binary Select to output Yn	2	15	ns
t _{PLH}	Binary Select to output Yn	2	15	ns
t _{PHL}	Enable to output Yn	2	17	ns
t _{PLH}	Enable to output Yn	2	14	ns

Notes:

1. Maximum allowable relative shift equals 50mV.
2. All specifications valid for radiation dose ≤ 1E6 rads(Si).

UT54ACS139/UT54ACTS139

Radiation-Hardened Dual 2-Line to 4-Line Decoders/Demultiplexers

FEATURES

- Incorporates two enable inputs to simplify cascading and/or data reception
- 1.2 μ radiation-hardened CMOS
 - Latchup immune
- High speed
- Low power consumption
- Single 5 volt supply
- Available QML Q or V processes
- Flexible package
 - 16-pin DIP
 - 16-lead flatpack

DESCRIPTION

The UT54ACS139 and the UT54ACTS139 are designed to be used in high-performance memory-decoding or data-routing applications requiring very short propagation delay times.

The devices consist of two individual two-line to four-line decoders in a single package. The active-low enable input can be used as a data line in demultiplexing applications.

The devices are characterized over full military temperature range of -55°C to +125°C.

FUNCTION TABLE

ENABLE INPUTS	SELECT INPUTS		OUTPUT			
	\overline{G}	B	A	$\overline{Y_0}$	$\overline{Y_1}$	$\overline{Y_2}$
H	X	X	H	H	H	H
L	L	L	L	H	H	H
L	L	H	H	L	H	H
L	H	L	H	H	L	H
L	H	H	H	H	H	L

PINOUTS

16-Pin DIP
Top View

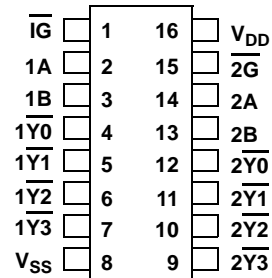

16-Lead Flatpack
Top View

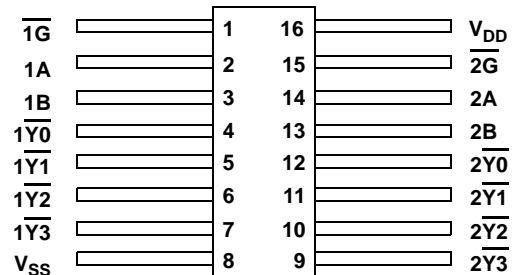

LOGIC DIAGRAM

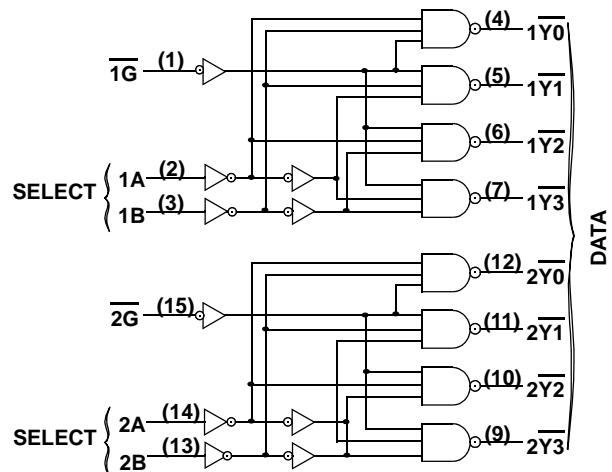

LOGIC SYMBOL

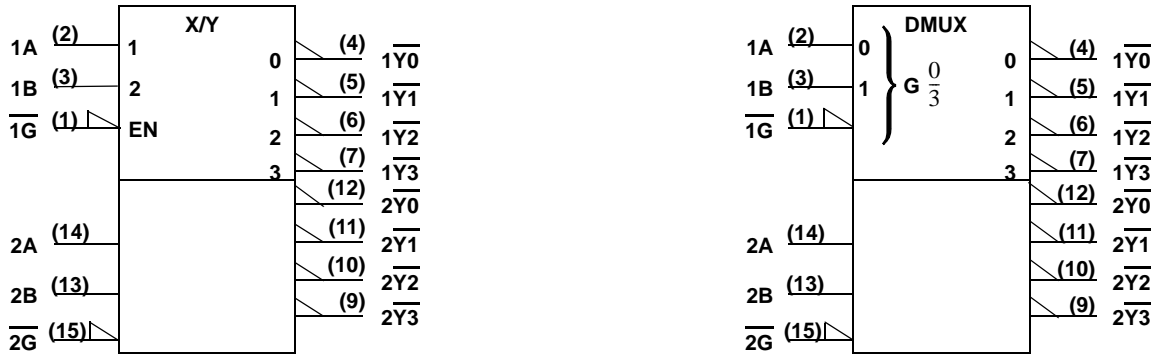

Note:

1. Logic symbols in accordance with ANSI/IEEE Std 91-1984 and IEC Publication 617-12.

RADIATION HARDNESS SPECIFICATIONS ¹

PARAMETER	LIMIT	UNITS
Total Dose	1.0E6	rads(Si)
SEU Threshold ²	80	MeV-cm ² /mg
SEL Threshold	120	MeV-cm ² /mg
Neutron Fluence	1.0E14	n/cm ²

Notes:

- 1. Logic will not latchup during radiation exposure within the limits defined in the table.
- 2. Device storage elements are immune to SEU affects.

ABSOLUTE MAXIMUM RATINGS

SYMBOL	PARAMETER	LIMIT	UNITS
V _{DD}	Supply voltage	-0.3 to 7.0	V
V _{I/O}	Voltage any pin	-.3 to V _{DD} +.3	V
T _{STG}	Storage Temperature range	-65 to +150	°C
T _J	Maximum junction temperature	+175	°C
T _{LS}	Lead temperature (soldering 5 seconds)	+300	°C
Θ _{JC}	Thermal resistance junction to case	20	°C/W
I _I	DC input current	±10	mA
P _D	Maximum power dissipation	1	W

Note:

1. Stresses outside the listed absolute maximum ratings may cause permanent damage to the device. This is a stress rating only, functional operation of the device at these or any other conditions beyond limits indicated in the operational sections is not recommended. Exposure to absolute maximum rating conditions for extended periods may affect device reliability.

RECOMMENDED OPERATING CONDITIONS

SYMBOL	PARAMETER	LIMIT	UNITS
V_{DD}	Supply voltage	4.5 to 5.5	V
V_{IN}	Input voltage any pin	0 to V_{DD}	V
T_C	Temperature range	-55 to + 125	°C

DC ELECTRICAL CHARACTERISTICS ⁷(V_{DD} = 5.0V ±10%; V_{SS} = 0V ⁶, -55°C < T_C < +125°C)

SYMBOL	PARAMETER	CONDITION	MIN	MAX	UNIT
V _{IL}	Low-level input voltage ¹ ACTS ACS			0.8 .3V _{DD}	V
V _{IH}	High-level input voltage ¹ ACTS ACS		.5V _{DD} .7V _{DD}		V
I _{IN}	Input leakage current ACTS/ACS	V _{IN} = V _{DD} or V _{SS}	-1	1	μA
V _{OL}	Low-level output voltage ³ ACTS ACS	I _{OL} = 8.0mA I _{OL} = 100μA		0.40 0.25	V
V _{OH}	High-level output voltage ³ ACTS ACS	I _{OH} = -8.0mA I _{OH} = -100μA	.7V _{DD} V _{DD} - 0.25		V
I _{OL}	Output current ¹⁰ (Sink)	V _{IN} = V _{DD} or V _{SS} V _{OL} = 0.4V	8		mA
I _{OH}	Output current ¹⁰ (Source)	V _{IN} = V _{DD} or V _{SS} V _{OH} = V _{DD} - 0.4V	-8		mA
I _{OS}	Short-circuit output current ^{2,4} ACTS/ACS	V _O = V _{DD} and V _{SS}	-200	200	mA
P _{total}	Power dissipation ^{2, 8, 9}	C _L = 50pF		1.8	mW/ MHz
I _{DDQ}	Quiescent Supply Current	V _{DD} = 5.5V		10	μA
ΔI _{DDQ}	Quiescent Supply Current Delta ACTS	For input under test V _{IN} = V _{DD} - 2.1V For all other inputs V _{IN} = V _{DD} or V _{SS} V _{DD} = 5.5V		1.6	mA
C _{IN}	Input capacitance ⁵	f = 1MHz @ 0V		15	pF
C _{OUT}	Output capacitance ⁵	f = 1MHz @ 0V		15	pF

UT54ACS139/UT54ACTS139

Notes:

1. Functional tests are conducted in accordance with MIL-STD-883 with the following input test conditions: $V_{IH} = V_{IH(min)} + 20\%$, $- 0\%$; $V_{IL} = V_{IL(max)} + 0\%$, $- 50\%$, as specified herein, for TTL, CMOS, or Schmitt compatible inputs. Devices may be tested using any input voltage within the above specified range, but are guaranteed to $V_{IH(min)}$ and $V_{IL(max)}$.
2. Supplied as a design limit but not guaranteed or tested.
3. Per MIL-PRF-38535, for current density $\leq 5.0E5$ amps/cm², the maximum product of load capacitance (per output buffer) times frequency should not exceed 3,765 pF/MHz.
4. Not more than one output may be shorted at a time for maximum duration of one second.
5. Capacitance measured for initial qualification and when design changes may affect the value. Capacitance is measured between the designated terminal and V_{SS} at frequency of 1MHz and a signal amplitude of 50mV rms maximum.
6. Maximum allowable relative shift equals 50mV.
7. All specifications valid for radiation dose $\leq 1E6$ rads(Si).
8. Power does not include power contribution of any TTL output sink current.
9. Power dissipation specified per switching output.
10. This value is guaranteed based on characterization data, but not tested.

AC ELECTRICAL CHARACTERISTICS ²(V_{DD} = 5.0V ±10%; V_{SS} = 0V ¹, -55°C < T_C < +125°C)

SYMBOL	PARAMETER	MINIMUM	MAXIMUM	UNIT
t _{PHL}	Select to output $\overline{Y_n}$	2	14	ns
t _{PLH}	Select to output $\overline{Y_n}$	2	15	ns
t _{PHL}	Enable to output $\overline{Y_n}$	2	14	ns
t _{PLH}	Enable to output $\overline{Y_n}$	2	12	ns

Notes:

1. Maximum allowable relative shift equals 50mV.
2. All specifications valid for radiation dose ≤ 1E6 rads(Si).

UT54ACS151/UT54ACTS151

Radiation-Hardened

1 of 8 Data Selectors/Multiplexers

FEATURES

- 8-line to 1-line multiplexers can perform as Boolean function generators, parallel-to-serial converters, and data source selectors
- 1.2μ radiation-hardened CMOS
 - Latchup immune
- High speed
- Low power consumption
- Single 5 volt supply
- Available QML Q or V processes
- Flexible package
 - 16-pin DIP
 - 16-lead flatpack

DESCRIPTION

The UT54ACS151 and the UT54ACTS151 are data multiplexers that provide full binary decoding to select one of eight data sources. The strobe input, \overline{G} , must be at a low logic level to enable the inputs. A high level at the strobe terminal forces the \overline{Y} output high and the Y output low.

The devices are characterized over full military temperature range of -55°C to +125°C.

FUNCTION TABLE

INPUTS				OUTPUT	
SELECT			STROBE	Y	\overline{Y}
C	B	A	\overline{G}		
X	X	X	H	L	H
L	L	L	L	D0	$\overline{D0}$
L	L	H	L	D1	$\overline{D1}$
L	H	L	L	D2	$\overline{D2}$
L	H	H	L	D3	$\overline{D3}$
H	L	L	L	D4	$\overline{D4}$
H	L	H	L	D5	$\overline{D5}$
H	H	L	L	D6	$\overline{D6}$
H	H	H	L	D7	$\overline{D7}$

H= high level, L = low level, X = irrelevant
 D0, D1... D7 = the level of the D respective input

PINOUTS

16-Pin DIP Top View

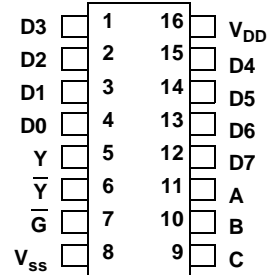

16-Lead Flatpack Top View

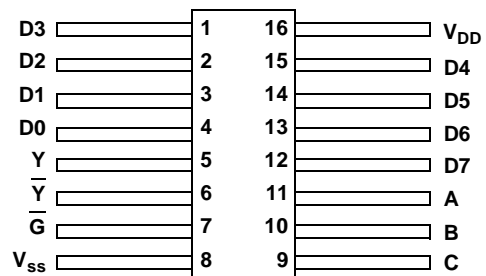

LOGIC SYMBOL

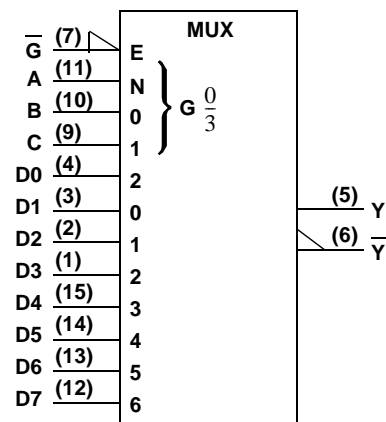

Note:

1. Logic symbol in accordance with ANSI/IEEE Std 91-1984 and IEC Publication 617-12.

LOGIC DIAGRAM

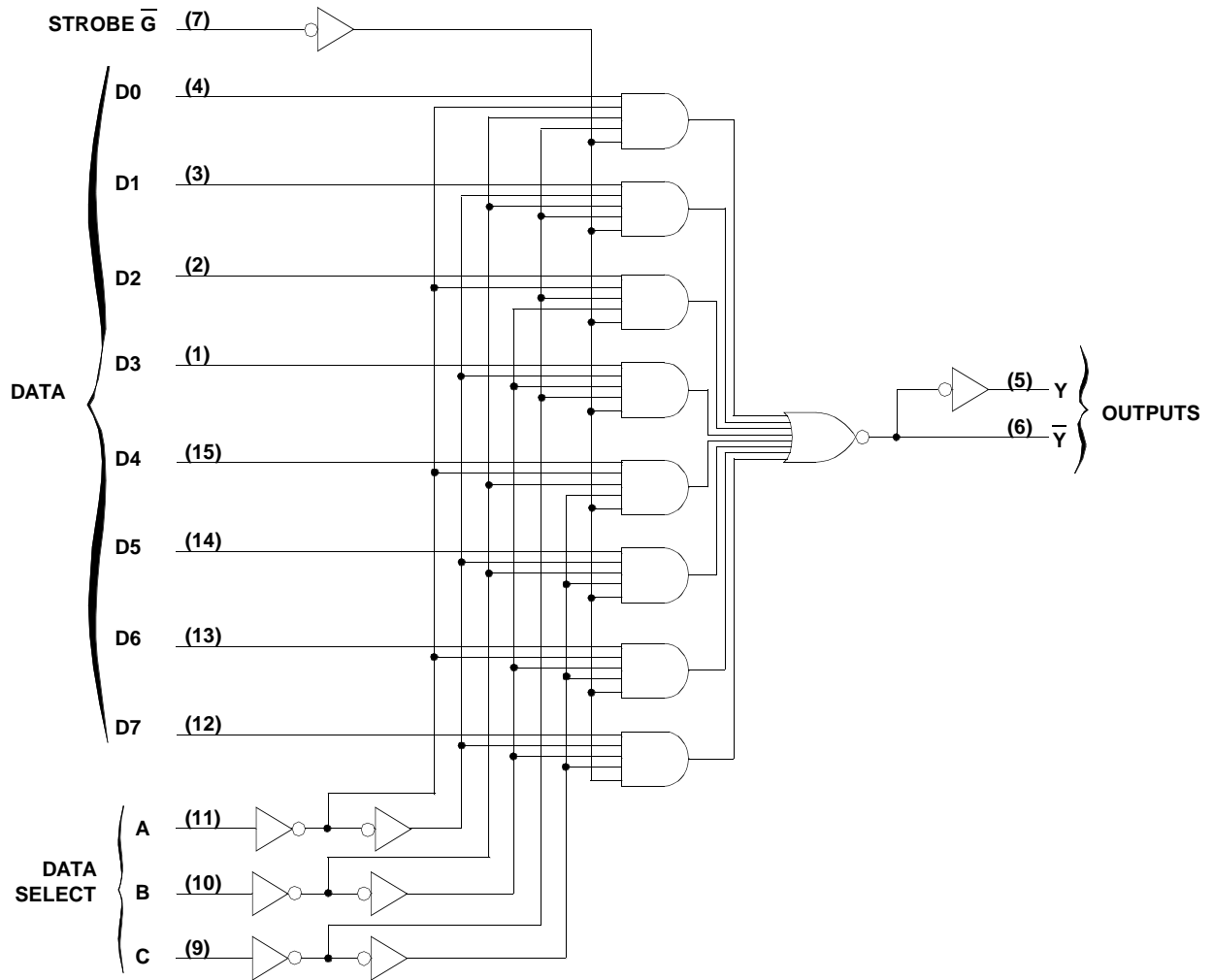

RADIATION HARDNESS SPECIFICATIONS ¹

PARAMETER	LIMIT	UNITS
Total Dose	1.0E6	rads(Si)
SEU Threshold ²	80	MeV-cm ² /mg
SEL Threshold	120	MeV-cm ² /mg
Neutron Fluence	1.0E14	n/cm ²

Notes:

1. Logic will not latchup during radiation exposure within the limits defined in the table.
2. Device storage elements are immune to SEU affects.

ABSOLUTE MAXIMUM RATINGS

SYMBOL	PARAMETER	LIMIT	UNITS
V _{DD}	Supply voltage	-0.3 to 7.0	V
V _{I/O}	Voltage any pin	-.3 to V _{DD} +.3	V
T _{STG}	Storage Temperature range	-65 to +150	°C
T _J	Maximum junction temperature	+175	°C
T _{LS}	Lead temperature (soldering 5 seconds)	+300	°C
Θ _{JC}	Thermal resistance junction to case	20	°C/W
I _I	DC input current	±10	mA
P _D	Maximum power dissipation	1	W

Note:

1. Stresses outside the listed absolute maximum ratings may cause permanent damage to the device. This is a stress rating only, functional operation of the device at these or any other conditions beyond limits indicated in the operational sections is not recommended. Exposure to absolute maximum rating conditions for extended periods may affect device reliability.

RECOMMENDED OPERATING CONDITIONS

SYMBOL	PARAMETER	LIMIT	UNITS
V _{DD}	Supply voltage	4.5 to 5.5	V
V _{IN}	Input voltage any pin	0 to V _{DD}	V
T _C	Temperature range	-55 to + 125	°C

DC ELECTRICAL CHARACTERISTICS ⁷ $(V_{DD} = 5.0V \pm 10\%; V_{SS} = 0V^6, -55^\circ C < T_C < +125^\circ C)$

SYMBOL	PARAMETER	CONDITION	MIN	MAX	UNIT
V_{IL}	Low-level input voltage ¹ ACTS ACS			0.8 .3 V_{DD}	V
V_{IH}	High-level input voltage ¹ ACTS ACS		.5 V_{DD} .7 V_{DD}		V
I_{IN}	Input leakage current ACTS/ACS	$V_{IN} = V_{DD}$ or V_{SS}	-1	1	μA
V_{OL}	Low-level output voltage ³ ACTS ACS	$I_{OL} = 8.0mA$ $I_{OL} = 100\mu A$		0.40 0.25	V
V_{OH}	High-level output voltage ³ ACTS ACS	$I_{OH} = -8.0mA$ $I_{OH} = -100\mu A$.7 V_{DD} $V_{DD} - 0.25$		V
I_{OS}	Short-circuit output current ^{2,4} ACTS/ACS	$V_O = V_{DD}$ and V_{SS}	-200	200	mA
I_{OL}	Output current ¹⁰ (Sink)	$V_{IN} = V_{DD}$ or V_{SS} $V_{OL} = 0.4V$	8		mA
I_{OH}	Output current ¹⁰ (Source)	$V_{IN} = V_{DD}$ or V_{SS} $V_{OH} = V_{DD} - 0.4V$	-8		mA
P_{total}	Power dissipation ^{2, 8, 9}	$C_L = 50pF$		2.3	mW/ MHz
I_{DDQ}	Quiescent Supply Current	$V_{DD} = 5.5V$		10	μA
ΔI_{DDQ}	Quiescent Supply Current Delta ACTS	For input under test $V_{IN} = V_{DD} - 2.1V$ For all other inputs $V_{IN} = V_{DD}$ or V_{SS} $V_{DD} = 5.5V$		1.6	mA
C_{IN}	Input capacitance ⁵	$f = 1MHz @ 0V$		15	pF
C_{OUT}	Output capacitance ⁵	$f = 1MHz @ 0V$		15	pF

UT54ACS151/UT54ACTS151

Notes:

1. Functional tests are conducted in accordance with MIL-STD-883 with the following input test conditions: $V_{IH} = V_{IH(min)} + 20\%$, $- 0\%$; $V_{IL} = V_{IL(max)} + 0\%$, $- 50\%$, as specified herein, for TTL, CMOS, or Schmitt compatible inputs. Devices may be tested using any input voltage within the above specified range, but are guaranteed to $V_{IH(min)}$ and $V_{IL(max)}$.
2. Supplied as a design limit but not guaranteed or tested.
3. Per MIL-PRF-38535, for current density $\leq 5.0E5$ amps/cm², the maximum product of load capacitance (per output buffer) times frequency should not exceed 3,765 pF/MHz.
4. Not more than one output may be shorted at a time for maximum duration of one second.
5. Capacitance measured for initial qualification and when design changes may affect the value. Capacitance is measured between the designated terminal and V_{SS} at frequency of 1MHz and a signal amplitude of 50mV rms maximum.
6. Maximum allowable relative shift equals 50mV.
7. All specifications valid for radiation dose $\leq 1E6$ rads(Si).
8. Power does not include power contribution of any TTL output sink current.
9. Power dissipation specified per switching output.
10. This value is guaranteed based on characterization data, but not tested.

AC ELECTRICAL CHARACTERISTICS ²(V_{DD} = 5.0V ±10%; V_{SS} = 0V¹, -55 °C < T_C < +125°C)

SYMBOL	PARAMETER	MINIMUM	MAXIMUM	UNIT
t _{PHL}	Input to Y	1	22	ns
t _{PLH}	Input to Y	1	23	ns
t _{PHL}	Input to \bar{Y}	1	25	ns
t _{PLH}	Input to \bar{Y}	1	19	ns
t _{PHL}	Select to Y	1	21	ns
t _{PLH}	Select to Y	1	22	ns
t _{PHL}	Select to \bar{Y}	1	24	ns
t _{PLH}	Select to \bar{Y}	1	21	ns
t _{PHL}	\bar{G} to Y	1	14	ns
t _{PLH}	\bar{G} to Y	1	11	ns
t _{PHL}	\bar{G} to \bar{Y}	1	14	ns
t _{PLH}	\bar{G} to \bar{Y}	1	10	ns

Notes:

1. Maximum allowable relative shift equals 50mV.
2. All specifications valid for radiation dose ≤ 1E6 rads(Si).

UT54ACS153/UT54ACTS153

Radiation-Hardened Dual 4 to 1 Multiplexers

FEATURES

- 1.2μ radiation-hardened CMOS
 - Latchup immune
- High speed
- Low power consumption
- Single 5 volt supply
- Available QML Q or V processes
- Flexible package
 - 16-pin DIP
 - 16-lead flatpack

DESCRIPTION

The UT54ACS153 and the UT54ACTS153 are dual four to one line selectors/multiplexers. Common inputs A and B select a value from one of four sources for each section and routes the value from each section to their respective outputs. Separate strobe inputs, \overline{G} are provided for each of the two four-line sections.

The devices are characterized over full military temperature range of -55°C to +125°C.

FUNCTION TABLE

SELECT INPUTS		DATA INPUTS				OUTPUT CONTROL	OUTPUT
B	A	C0	C1	C2	C3	\overline{G}	Y
X	X	X	X	X	X	H	L
L	L	L	X	X	X	L	L
L	L	H	X	X	X	L	H
L	H	X	L	X	X	L	L
L	H	X	H	X	X	L	H
H	L	X	X	L	X	L	L
H	L	X	X	H	X	L	H
H	H	X	X	X	L	L	L
H	H	X	X	X	H	L	H

PINOUTS

16-Pin DIP Top View

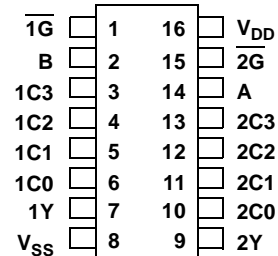

16-Lead Flatpack Top View

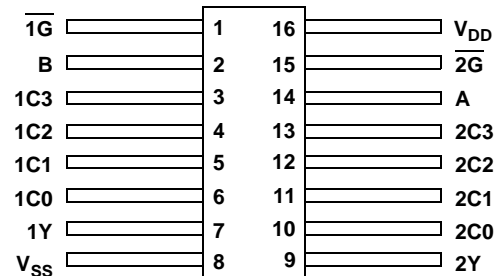

LOGIC SYMBOL

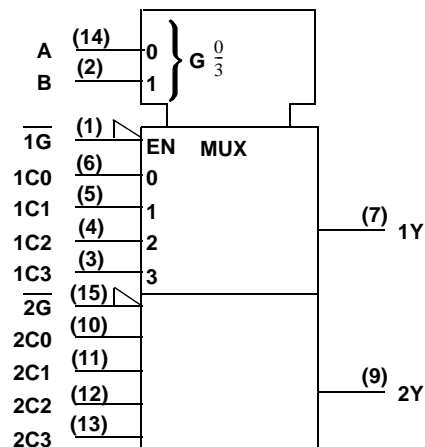

Note:

1. Logic symbol in accordance with ANSI/IEEE Std 91-1984 and IEC Publication 617-12.

LOGIC DIAGRAM

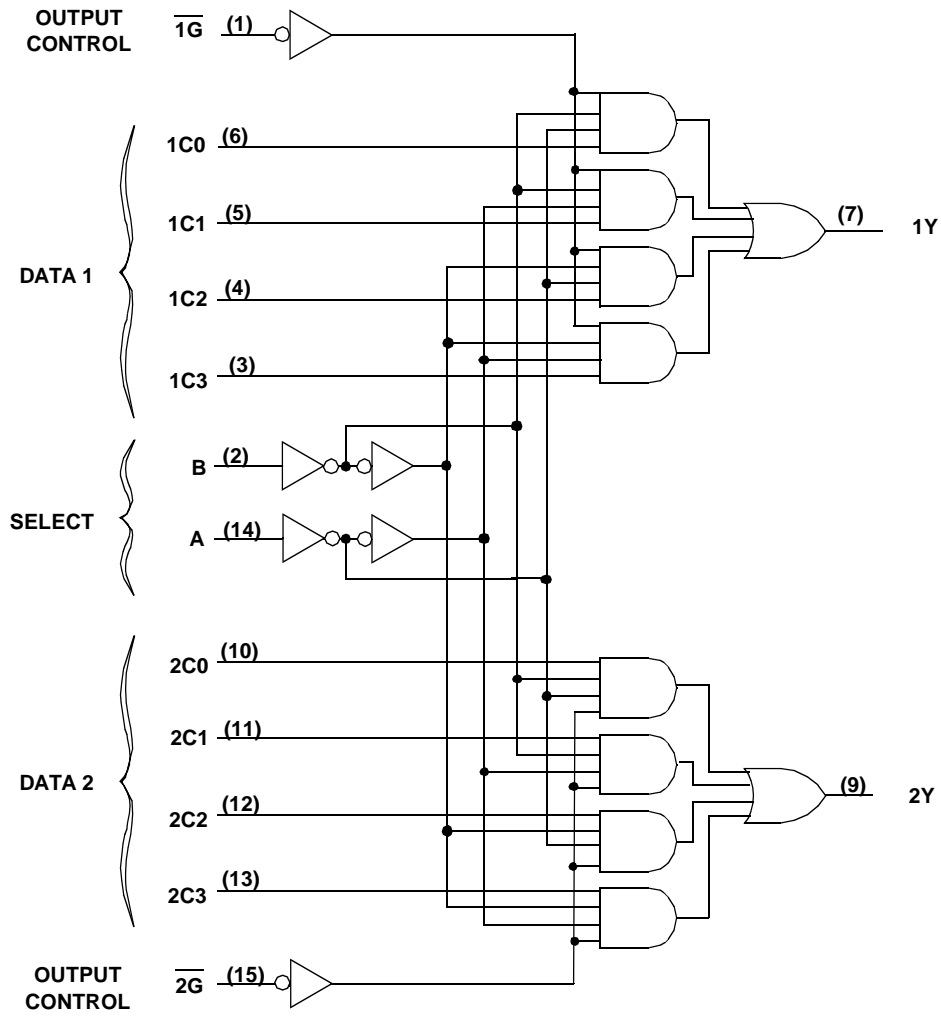

RADIATION HARDNESS SPECIFICATIONS ¹

PARAMETER	LIMIT	UNITS
Total Dose	1.0E6	rads(Si)
SEU Threshold ²	80	MeV-cm ² /mg
SEL Threshold	120	MeV-cm ² /mg
Neutron Fluence	1.0E14	n/cm ²

Notes:

1. Logic will not latchup during radiation exposure within the limits defined in the table.
2. Device storage elements are immune to SEU affects.

ABSOLUTE MAXIMUM RATINGS

SYMBOL	PARAMETER	LIMIT	UNITS
V _{DD}	Supply voltage	-0.3 to 7.0	V
V _{I/O}	Voltage any pin	-.3 to V _{DD} +.3	V
T _{STG}	Storage Temperature range	-65 to +150	°C
T _J	Maximum junction temperature	+175	°C
T _{LS}	Lead temperature (soldering 5 seconds)	+300	°C
Θ _{JC}	Thermal resistance junction to case	20	°C/W
I _I	DC input current	±10	mA
P _D	Maximum power dissipation	1	W

Note:

1. Stresses outside the listed absolute maximum ratings may cause permanent damage to the device. This is a stress rating only, functional operation of the device at these or any other conditions beyond limits indicated in the operational sections is not recommended. Exposure to absolute maximum rating conditions for extended periods may affect device reliability.

RECOMMENDED OPERATING CONDITIONS

SYMBOL	PARAMETER	LIMIT	UNITS
V _{DD}	Supply voltage	4.5 to 5.5	V
V _{IN}	Input voltage any pin	0 to V _{DD}	V
T _C	Temperature range	-55 to + 125	°C

DC ELECTRICAL CHARACTERISTICS ⁷(V_{DD} = 5.0V ±10%; V_{SS} = 0V ⁶, -55°C < T_C < +125 °C)

SYMBOL	PARAMETER	CONDITION	MIN	MAX	UNIT
V _{IL}	Low-level input voltage ¹ ACTS ACS			0.8 .3V _{DD}	V
V _{IH}	High-level input voltage ¹ ACTS ACS		.5V _{DD} .7V _{DD}		V
I _{IN}	Input leakage current ACTS/ACS	V _{IN} = V _{DD} or V _{SS}	-1	1	μA
V _{OL}	Low-level output voltage ³ ACTS ACS	I _{OL} = 8.0mA I _{OL} = 100μA		0.40 0.25	V
V _{OH}	High-level output voltage ³ ACTS ACS	I _{OH} = -8.0mA I _{OH} = -100μA	.7V _{DD} V _{DD} - 0.25		V
I _{OS}	Short-circuit output current ^{2,4} ACTS/ACS	V _O = V _{DD} and V _{SS}	-200	200	mA
I _{OL}	Output current ¹⁰ (Sink)	V _{IN} = V _{DD} or V _{SS} V _{OL} = 0.4V	8		mA
I _{OH}	Output current ¹⁰ (Source)	V _{IN} = V _{DD} or V _{SS} V _{OH} = V _{DD} - 0.4V	-8		mA
P _{total}	Power dissipation ^{2, 8, 9}	C _L = 50pF		2.1	mW/ MHz
ΔI _{DDQ}	Quiescent Supply Current Delta ACTS	For input under test V _{IN} = V _{DD} - 2.1V For all other inputs V _{IN} = V _{DD} or V _{SS} V _{DD} = 5.5V		1.6	mA
I _{DDQ}	Quiescent Supply Current	V _{DD} = 5.5V		10	μA
C _{IN}	Input capacitance ⁵	f = 1MHz @ 0V		15	pF
C _{OUT}	Output capacitance ⁵	f = 1MHz @ 0V		15	pF

UT54ACS153/UT54ACTS153

Notes:

1. Functional tests are conducted in accordance with MIL-STD-883 with the following input test conditions: $V_{IH} = V_{IH(min)} + 20\%$, $- 0\%$; $V_{IL} = V_{IL(max)} + 0\%$, $- 50\%$, as specified herein, for TTL, CMOS, or Schmitt compatible inputs. Devices may be tested using any input voltage within the above specified range, but are guaranteed to $V_{IH(min)}$ and $V_{IL(max)}$.
2. Supplied as a design limit but not guaranteed or tested.
3. Per MIL-PRF-38535, for current density $\leq 5.0E5$ amps/cm², the maximum product of load capacitance (per output buffer) times frequency should not exceed 3,765 pF/MHz.
4. Not more than one output may be shorted at a time for maximum duration of one second.
5. Capacitance measured for initial qualification and when design changes may affect the value. Capacitance is measured between the designated terminal and V_{SS} at frequency of 1MHz and a signal amplitude of 50mV rms maximum.
6. Maximum allowable relative shift equals 50mV.
7. All specifications valid for radiation dose $\leq 1E6$ rads(Si).
8. Power does not include power contribution of any TTL output sink current.
9. Power dissipation specified per switching output.
10. This value is guaranteed based on characterization data, but not tested.

AC ELECTRICAL CHARACTERISTICS ²(V_{DD} = 5.0V \pm 10%; V_{SS} = 0V ¹, -55°C < T_C < +125°C)

SYMBOL	PARAMETER	MINIMUM	MAXIMUM	UNIT
t _{PHL}	Data to output Yn	2	16	ns
t _{PLH}	Data to output Yn	2	12	ns
t _{PHL}	Strobe to output Yn	1	15	ns
t _{PLH}	Strobe to output Yn	1	14	ns
t _{PHL}	Select to output Yn	2	16	ns
t _{PLH}	Select to output Yn	2	14	ns

Notes:

1. Maximum allowable relative shift equals 50mV.
2. All specifications valid for radiation dose \leq 1E6 rads(Si).

UT54ACS157/UT54ACTS157

Radiation-Hardened Quadruple 2 to 1 Multiplexers

FEATURES

- 1.2μ radiation-hardened CMOS
 - Latchup immune
- High speed
- Low power consumption
- Single 5 volt supply
- Available QML Q or V processes
- Flexible package
 - 16-pin DIP
 - 16-lead flatpack

DESCRIPTION

The UT54ACS157 and the UT54ACTS157 are monolithic data selectors/multiplexers. A 4-bit word is selected from one of two sources and is routed to the four outputs. A separate strobe input, \overline{G} , is provided.

The devices are characterized over full military temperature range of -55°C to +125°C.

FUNCTION TABLE

INPUTS				OUTPUT
STROBE \overline{G}	SELECT A/B	DATA		Y
		A	B	
H	X	X	X	L
L	L	L	X	L
L	L	H	X	H
L	H	X	L	L
L	H	X	H	H

PINOUTS

16-Pin DIP Top View

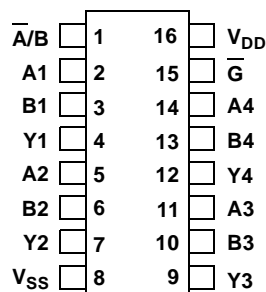

16-Lead Flatpack Top View

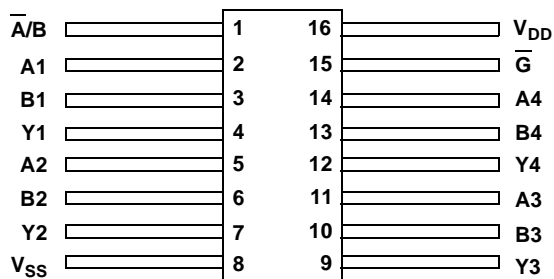

LOGIC SYMBOL

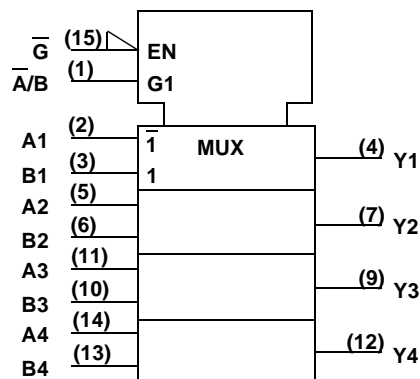

Note:

1. Logic symbol in accordance with ANSI/IEEE Std 91-1984 and IEC Publication 617-12.

LOGIC DIAGRAM

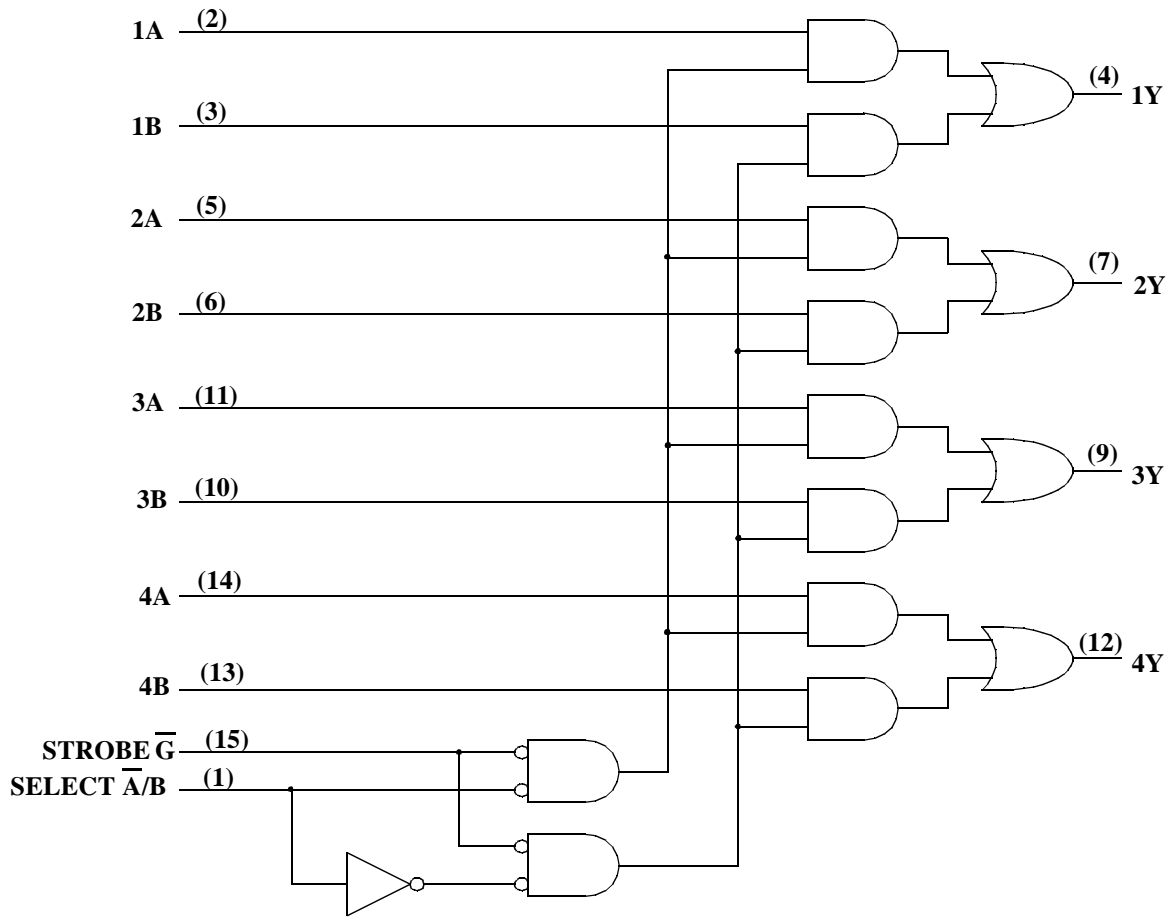

RADIATION HARDNESS SPECIFICATIONS ¹

PARAMETER	LIMIT	UNITS
Total Dose	1.0E6	rads(Si)
SEU Threshold ²	80	MeV-cm ² /mg
SEL Threshold	120	MeV-cm ² /mg
Neutron Fluence	1.0E14	n/cm ²

Notes:

1. Logic will not latchup during radiation exposure within the limits defined in the table.
2. Device storage elements are immune to SEU affects.

ABSOLUTE MAXIMUM RATINGS

SYMBOL	PARAMETER	LIMIT	UNITS
V _{DD}	Supply voltage	-0.3 to 7.0	V
V _{I/O}	Voltage any pin	-.3 to V _{DD} +.3	V
T _{STG}	Storage Temperature range	-65 to +150	°C
T _J	Maximum junction temperature	+175	°C
T _{LS}	Lead temperature (soldering 5 seconds)	+300	°C
Θ _{JC}	Thermal resistance junction to case	20	°C/W
I _I	DC input current	±10	mA
P _D	Maximum power dissipation	1	W

Note:

1. Stresses outside the listed absolute maximum ratings may cause permanent damage to the device. This is a stress rating only, functional operation of the device at these or any other conditions beyond limits indicated in the operational sections is not recommended. Exposure to absolute maximum rating conditions for extended periods may affect device reliability.

RECOMMENDED OPERATING CONDITIONS

SYMBOL	PARAMETER	LIMIT	UNITS
V _{DD}	Supply voltage	4.5 to 5.5	V
V _{IN}	Input voltage any pin	0 to V _{DD}	V
T _C	Temperature range	-55 to + 125	°C

DC ELECTRICAL CHARACTERISTICS ⁷ $(V_{DD} = 5.0V \pm 10\%; V_{SS} = 0V^6, -55^{\circ}C < T_C < +125^{\circ}C)$

SYMBOL	PARAMETER	CONDITION	MIN	MAX	UNIT
V_{IL}	Low-level input voltage ¹ ACTS ACS			0.8 .3 V_{DD}	V
V_{IH}	High-level input voltage ¹ ACTS ACS		.5 V_{DD} .7 V_{DD}		V
I_{IN}	Input leakage current ACTS/ACS	$V_{IN} = V_{DD}$ or V_{SS}	-1	1	μA
V_{OL}	Low-level output voltage ³ ACTS ACS	$I_{OL} = 8.0mA$ $I_{OL} = 100\mu A$		0.40 0.25	V
V_{OH}	High-level output voltage ³ ACTS ACS	$I_{OH} = -8.0mA$ $I_{OH} = -100\mu A$.7 V_{DD} $V_{DD} - 0.25$		V
I_{OS}	Short-circuit output current ^{2,4} ACTS/ACS	$V_O = V_{DD}$ and V_{SS}	-200	200	mA
I_{OL}	Output current ¹⁰ (Sink)	$V_{IN} = V_{DD}$ or V_{SS} $V_{OL} = 0.4V$	8		mA
I_{OH}	Output current ¹⁰ (Source)	$V_{IN} = V_{DD}$ or V_{SS} $V_{OH} = V_{DD} - 0.4V$	-8		mA
P_{total}	Power dissipation ^{2, 8, 9}	$C_L = 50pF$		1.9	mW/ MHz
I_{DDQ}	Quiescent Supply Current	$V_{DD} = 5.5V$		10	μA
ΔI_{DDQ}	Quiescent Supply Current Delta ACTS	For input under test $V_{IN} = V_{DD} - 2.1V$ For all other inputs $V_{IN} = V_{DD}$ or V_{SS} $V_{DD} = 5.5V$		1.6	mA
C_{IN}	Input capacitance ⁵	$f = 1MHz @ 0V$		15	pF
C_{OUT}	Output capacitance ⁵	$f = 1MHz @ 0V$		15	pF

UT54ACS157/UT54ACTS157

Notes:

1. Functional tests are conducted in accordance with MIL-STD-883 with the following input test conditions: $V_{IH} = V_{IH(min)} + 20\%$, $- 0\%$; $V_{IL} = V_{IL(max)} + 0\%$, $- 50\%$, as specified herein, for TTL, CMOS, or Schmitt compatible inputs. Devices may be tested using any input voltage within the above specified range, but are guaranteed to $V_{IH(min)}$ and $V_{IL(max)}$.
2. Supplied as a design limit but not guaranteed or tested.
3. Per MIL-PRF-38535, for current density $\leq 5.0E5$ amps/cm², the maximum product of load capacitance (per output buffer) times frequency should not exceed 3,765 pF/MHz.
4. Not more than one output may be shorted at a time for maximum duration of one second.
5. Capacitance measured for initial qualification and when design changes may affect the value. Capacitance is measured between the designated terminal and V_{SS} at frequency of 1MHz and a signal amplitude of 50mV rms maximum.
6. Maximum allowable relative shift equals 50mV.
7. All specifications valid for radiation dose $\leq 1E6$ rads(Si).
8. Power does not include power contribution of any TTL output sink current.
9. Power dissipation specified per switching output.
10. This value is guaranteed based on characterization data, but not tested.

AC ELECTRICAL CHARACTERISTICS ²(V_{DD} = 5.0V \pm 10%; V_{SS} = 0V ¹, -55°C < T_C < +125°C)

SYMBOL	PARAMETER	MINIMUM	MAXIMUM	UNIT
t _{PHL}	Data to output Yn	2	15	ns
t _{PLH}	Data to output Yn	2	13	ns
t _{PHL}	Strobe to output Yn	2	15	ns
t _{PLH}	Strobe to output Yn	2	12	ns
t _{PHL}	Select to output Yn	2	16	ns
t _{PLH}	Select to output Yn	2	14	ns

Notes:

1. Maximum allowable relative shift equals 50mV.
2. All specifications valid for radiation dose \leq 1E6 rads(Si).

UT54ACS163/UT54ACTS163

Radiation-Hardened 4-Bit Synchronous Counters

FEATURES

- Internal look-ahead for fast counting
- Carry output for n-bit cascading
- Synchronous counting
- Synchronously programmable
- 1.2 μ radiation-hardened CMOS
 - Latchup immune
- High speed
- Low power consumption
- Single 5 volt supply
- Available QML Q or V processes
- Flexible package
 - 16-pin DIP
 - 16-lead flatpack

DESCRIPTION

The UT54ACS163 and the UT54ACTS163 are synchronous presettable 4-bit binary counters that feature internal carry look-ahead logic for high-speed counting designs. Synchronous operation occurs by having all flip-flops clocked simultaneously so that the outputs change coincident with each other when instructed by the count-enable inputs and internal gating. A buffered clock input triggers the four flip-flops on the rising (positive-going) edge of the clock input waveform.

The counters are fully programmable (i.e., they may be preset to any number between 0 and 15). Presetting is synchronous; applying a low level at the load input disables the counter and causes the outputs to agree with the load data after the next clock pulse.

The clear function is synchronous and a low level at the clear input sets all four of the flip-flop outputs low after the next clock pulse. This synchronous clear allows the count length to be modified by decoding the Q outputs for the maximum count desired.

The counters feature a fully independent clock circuit. Changes at control inputs (ENP, ENT, or LOAD) that modify the operating mode have no effect on the contents of the counter until clocking occurs. The function of the counter (whether enabled, disabled, loading, or counting) will be dictated solely by the conditions meeting the stable setup and hold times.

The devices are characterized over full military temperature range of -55°C to +125°C.

PINOUTS

**16-Pin DIP
Top View**

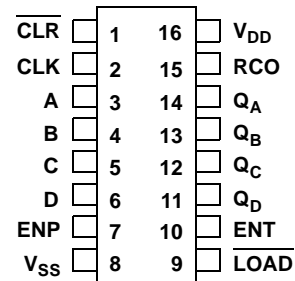

**16-Lead Flatpack
Top View**

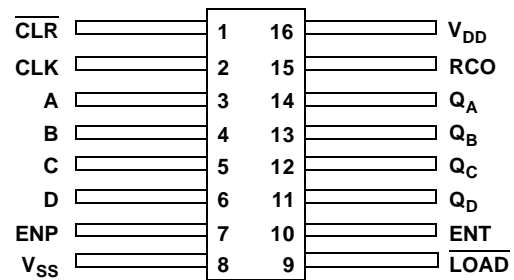

LOGIC SYMBOL

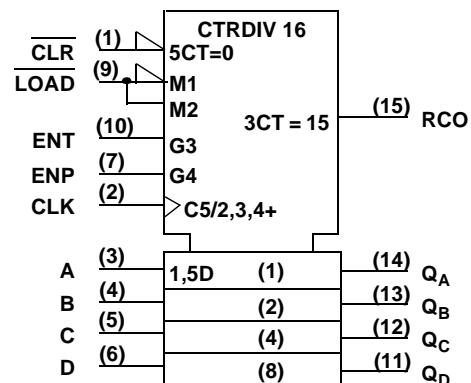

Note:

1. Logic symbol in accordance with ANSI/IEEE Std 91-1984 and IEC Publication 617-12.

FUNCTION TABLE

Operating Mode	$\overline{\text{CLR}}$	CLK	ENP	ENT	$\overline{\text{LOAD}}$	DATA A,B,C,D	Q_N	RCO
Reset (Clear)	<i>l</i>	\uparrow	X	X	X	X	L	L
Parallel Load	h^3	\uparrow	X	X	<i>l</i>	<i>l</i>	L	L
	h^3	\uparrow	X	X	<i>l</i>	<i>h</i>	H	₁ L
Count	h^3	\uparrow	<i>h</i>	<i>h</i>	<i>h</i>	X	Count	₁
Inhibit	h^3	X	<i>l</i> ²	X	h^3	X	Q_N	₁ L
	h^3	X	X	<i>l</i> ²	h^3	X	Q_N	L

H = High voltage level h = High voltage level one setup time prior to the low-to-high clock transition
 L = Low voltage level *l* = Low voltage level one setup time prior to the low-to-high clock transition

Notes:

1. The RCO output is high when ENT is high and the counter is at terminal count HHHH.
2. The high-to-low transition of ENP or ENT should only occur while CLK is high for conventional operations.
3. The low-to-high transition of $\overline{\text{LOAD}}$ or $\overline{\text{CLR}}$ should only occur while CLK is high for conventional operations.

LOGIC DIAGRAM

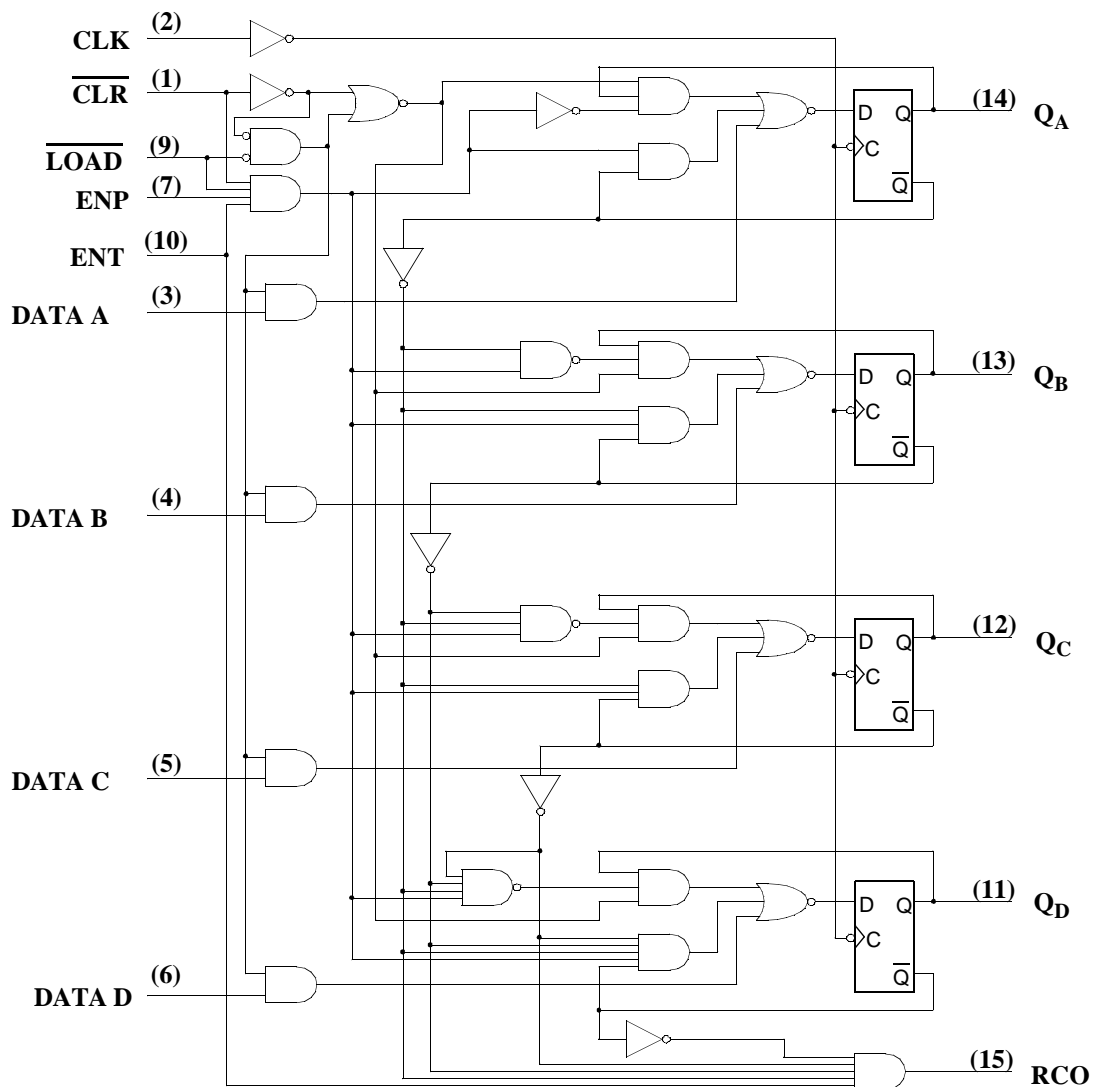

RADIATION HARDNESS SPECIFICATIONS ¹

PARAMETER	LIMIT	UNITS
Total Dose	1.0E6	rads(Si)
SEU Threshold ²	80	MeV-cm ² /mg
SEL Threshold	120	MeV-cm ² /mg
Neutron Fluence	1.0E14	n/cm ²

Notes:

1. Logic will not latchup during radiation exposure within the limits defined in the table.
2. Device storage elements are immune to SEU affects.

ABSOLUTE MAXIMUM RATINGS

SYMBOL	PARAMETER	LIMIT	UNITS
V _{DD}	Supply voltage	0.3 to 7.0	V
V _{I/O}	Voltage any pin	-.3 to V _{DD} +.3	V
T _{STG}	Storage Temperature range	-65 to +150	°C
T _J	Maximum junction temperature	+175	°C
T _{LS}	Lead temperature (soldering 5 seconds)	+300	°C
Θ _{JC}	Thermal resistance junction to case	20	°C/W
I _I	DC input current	±10	mA
P _D	Maximum power dissipation	1	W

Note:

1. Stresses outside the listed absolute maximum ratings may cause permanent damage to the device. This is a stress rating only, functional operation of the device at these or any other conditions beyond limits indicated in the operational sections is not recommended. Exposure to absolute maximum rating conditions for extended periods may affect device reliability.

RECOMMENDED OPERATING CONDITIONS

SYMBOL	PARAMETER	LIMIT	UNITS
V _{DD}	Supply voltage	4.5 to 5.5	V
V _{IN}	Input voltage any pin	0 to V _{DD}	V
T _C	Temperature range	-55 to + 125	°C

DC ELECTRICAL CHARACTERISTICS ⁷(V_{DD} = 5.0V ±10%; V_{SS} = 0V ⁶, -55°C < T_C < +125°C)

SYMBOL	PARAMETER	CONDITION	MIN	MAX	UNIT
V _{IL}	Low-level input voltage ¹ ACTS ACS			0.8 .3V _{DD}	V
V _{IH}	High-level input voltage ¹ ACTS ACS		.5V _{DD} .7V _{DD}		V
I _{IN}	Input leakage current ACTS/ACS	V _{IN} = V _{DD} or V _{SS}	-1	1	μA
V _{OL}	Low-level output voltage ³ ACTS ACS	I _{OL} = 8.0mA I _{OL} = 100μA		0.40 0.25	V
V _{OH}	High-level output voltage ³ ACTS ACS	I _{OH} = -8.0mA I _{OH} = -100μA	.7V _{DD} V _{DD} - 0.25		V
I _{OS}	Short-circuit output current ^{2,4} ACTS/ACS	V _O = V _{DD} and V _{SS}	-200	200	mA
I _{OL}	Output current ¹⁰ (Sink)	V _{IN} = V _{DD} or V _{SS} V _{OL} = 0.4V	8		mA
I _{OH}	Output current ¹⁰ (Source)	V _{IN} = V _{DD} or V _{SS} V _{OH} = V _{DD} - 0.4V	-8		mA
P _{total}	Power dissipation ^{2, 8, 9}	C _L = 50pF		1.9	mW/MHz
I _{DDQ}	Quiescent Supply Current	V _{DD} = 5.5V		10	μA
ΔI _{DDQ}	Quiescent Supply Current Delta ACTS	For input under test V _{IN} = V _{DD} - 2.1V For all other inputs V _{IN} = V _{DD} or V _{SS} V _{DD} = 5.5V		1.6	mA
C _{IN}	Input capacitance ⁵	f = 1MHz @ 0V		15	pF
C _{OUT}	Output capacitance ⁵	f = 1MHz @ 0V		15	pF

UT54ACS163/UT54ACTS163

Notes:

1. Functional tests are conducted in accordance with MIL-STD-883 with the following input test conditions: $V_{IH} = V_{IH(min)} + 20\%$, $- 0\%$; $V_{IL} = V_{IL(max)} + 0\%$, $- 50\%$, as specified herein, for TTL, CMOS, or Schmitt compatible inputs. Devices may be tested using any input voltage within the above specified range, but are guaranteed to $V_{IH(min)}$ and $V_{IL(max)}$.
2. Supplied as a design limit but not guaranteed or tested.
3. Per MIL-PRF-38535, for current density $\leq 5.0E5$ amps/cm², the maximum product of load capacitance (per output buffer) times frequency should not exceed 3,765 pF/MHz.
4. Not more than one output may be shorted at a time for maximum duration of one second.
5. Capacitance measured for initial qualification and when design changes may affect the value. Capacitance is measured between the designated terminal and V_{SS} at frequency of 1MHz and a signal amplitude of 50mV rms maximum.
6. Maximum allowable relative shift equals 50mV.
7. All specifications valid for radiation dose $\leq 1E6$ rads(Si).
8. Power does not include power contribution of any TTL output sink current.
9. Power dissipation specified per switching output.
10. This value is guaranteed based on characterization data, but not tested.

AC ELECTRICAL CHARACTERISTICS ²(V_{DD} = 5.0V ±10%; V_{SS} = 0V ¹, -55°C < T_C < +125°C)

SYMBOL	PARAMETER	MINIMUM	MAXIMUM	UNIT
t _{PHL}	CLK to Q _n	4	24	ns
t _{PLH}	CLK to Q _n	4	22	ns
t _{PHL}	CLK to RCO	4	22	ns
t _{PLH}	CLK to RCO	4	24	ns
t _{PHL}	ENT to RCO	1	13	ns
t _{PLH}	ENT to RCO	1	14	ns
f _{MAX}	Maximum clock frequency		77	MHz
t _{SU1}	A, B, C, D Setup time before CLK ↑	6		ns
t _{SU2}	$\overline{\text{LOAD}}$, ENP, ENT, $\overline{\text{CLR}}$ low or high Setup time before CLK ↑	6		ns
t _{H1} ³	Data hold time after CLK ↑	1		ns
t _{H2}	All synchronous inputs hold time after CLK ↑	1		ns
t _w	Minimum pulse width $\overline{\text{CLR}}$ low CLK high CLK low	7		ns

Notes:

1. Maximum allowable relative shift equals 50mV.
2. All specifications valid for radiation dose ≤ 1E6 rads(Si).
3. Based on characterization, hold time (t_{H1}) of 0ns can be assumed if data setup time (t_{SU1}) is ≥10ns. This is guaranteed, but not tested.

UT54ACS164/UT54ACTS164

Radiation-Hardened 8-Bit Shift Registers

FEATURES

- AND-gated (enable/disable) serial inputs
- Fully buffered clock and serial inputs
- Direct clear
- 1.2 μ radiation-hardened CMOS
 - Latchup immune
- High speed
- Low power consumption
- Single 5 volt supply
- Available QML Q or V processes
- Flexible package
 - 14-pin DIP
 - 14-lead flatpack

DESCRIPTION

The UT54ACS164 and the UT54ACTS164 are 8-bit shift registers which feature AND-gated serial inputs and an asynchronous clear. The gated serial inputs (A and B) permit complete control over incoming data. A low at either input inhibits entry of new data and resets the first flip-flop to the low level at the next clock pulse. A high-level at both serial inputs sets the first flip-flop to the high level at the next clock pulse. Data at the serial inputs may be changed while the clock is high or low, providing the minimum setup time requirements are met. Clocking occurs on the low-to-high-level transition of the clock input.

The devices are characterized over full military temperature range of -55°C to +125°C.

FUNCTION TABLE

INPUTS				OUTPUTS		
$\overline{\text{CLR}}$	CLK	A	B	Q_A	$Q_B \dots Q_H$	
L	X	X	X	L	L	L
H	L	X	X	Q_{A0}	Q_{B0}	Q_{H0}
H	\uparrow	H	H	H	Q_{An}	Q_{Gn}
H	\uparrow	L	X	L	Q_{An}	Q_{Gn}
H	\uparrow	X	L	L	Q_{An}	Q_{Gn}

Notes:

1. Q_{A0} , Q_{B0} , Q_{H0} = the level of Q_A , Q_B or Q_H , respectively, before the indicated steady-state input conditions were established.
2. Q_{An} and Q_{Gn} = the level of Q_A or Q_G before the most recent \uparrow transition of the clock; indicates a one-bit shift.

PINOUTS

14-Pin DIP Top View

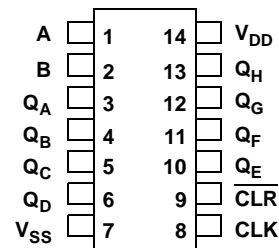

14-Lead Flatpack Top View

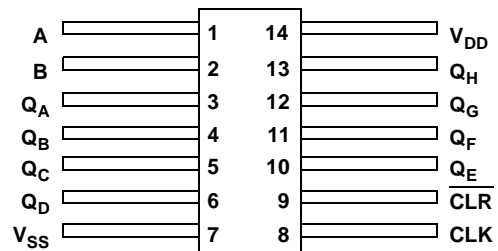

LOGIC SYMBOL

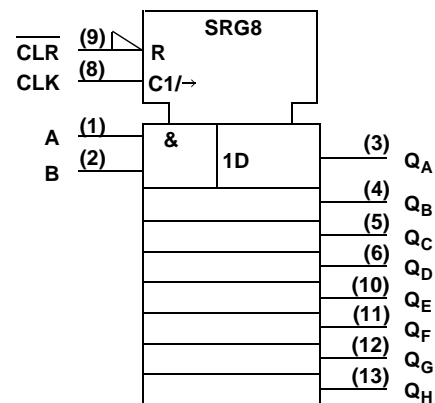

Note:

1. Logic symbol in accordance with ANSI/IEEE Std 91-1984 and IEC Publication 617-12.

LOGIC DIAGRAM

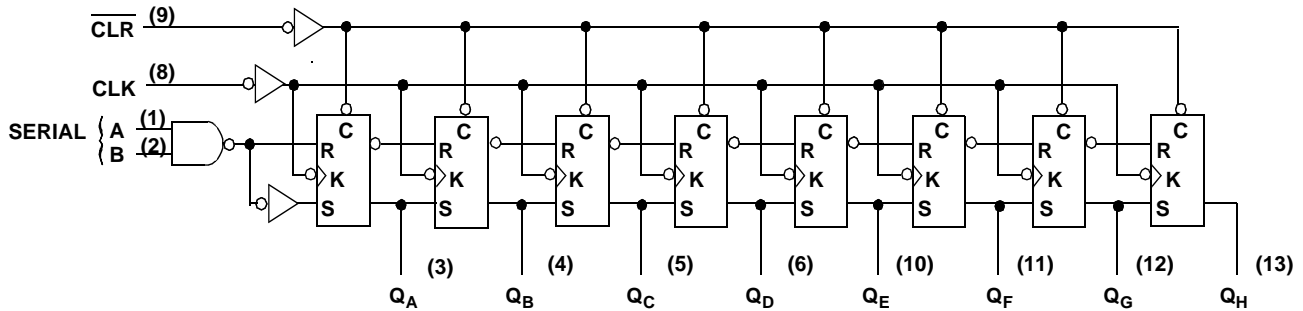

RADIATION HARDNESS SPECIFICATIONS ¹

PARAMETER	LIMIT	UNITS
Total Dose	1.0E6	rads(Si)
SEU Threshold ²	80	MeV-cm ² /mg
SEL Threshold	120	MeV-cm ² /mg
Neutron Fluence	1.0E14	n/cm ²

Notes:

1. Logic will not latchup during radiation exposure within the limits defined in the table.
2. Device storage elements are immune to SEU affects.

ABSOLUTE MAXIMUM RATINGS

SYMBOL	PARAMETER	LIMIT	UNITS
V _{DD}	Supply voltage	-0.3 to 7.0	V
V _{I/O}	Voltage any pin	-.3 to V _{DD} +.3	V
T _{STG}	Storage Temperature range	-65 to +150	°C
T _J	Maximum junction temperature	+175	°C
T _{LS}	Lead temperature (soldering 5 seconds)	+300	°C
Θ _{JC}	Thermal resistance junction to case	20	°C/W
I _I	DC input current	±10	mA
P _D	Maximum power dissipation	1	W

Note:

1. Stresses outside the listed absolute maximum ratings may cause permanent damage to the device. This is a stress rating only, functional operation of the device at these or any other conditions beyond limits indicated in the operational sections is not recommended. Exposure to absolute maximum rating conditions for extended periods may affect device reliability.

RECOMMENDED OPERATING CONDITIONS

SYMBOL	PARAMETER	LIMIT	UNITS
V_{DD}	Supply voltage	4.5 to 5.5	V
V_{IN}	Input voltage any pin	0 to V_{DD}	V
T_C	Temperature range	-55 to + 125	°C

DC ELECTRICAL CHARACTERISTICS ⁷ $(V_{DD} = 5.0V \pm 10\%; V_{SS} = 0V^6, -55^{\circ}C < T_C < +125^{\circ}C)$

SYMBOL	PARAMETER	CONDITION	MIN	MAX	UNIT
V_{IL}	Low-level input voltage ¹ ACTS ACS			0.8 .3 V_{DD}	V
V_{IH}	High-level input voltage ¹ ACTS ACS		.5 V_{DD} .7 V_{DD}		V
I_{IN}	Input leakage current ACTS/ACS	$V_{IN} = V_{DD}$ or V_{SS}	-1	1	μA
V_{OL}	Low-level output voltage ³ ACTS ACS	$I_{OL} = 8.0mA$ $I_{OL} = 100\mu A$		0.40 0.25	V
V_{OH}	High-level output voltage ³ ACTS ACS	$I_{OH} = -8.0mA$ $I_{OH} = -100\mu A$.7 V_{DD} $V_{DD} - 0.25$		V
I_{OS}	Short-circuit output current ^{2,4} ACTS/ACS	$V_O = V_{DD}$ and V_{SS}	-200	200	mA
I_{OL}	Output current ¹⁰ (Sink)	$V_{IN} = V_{DD}$ or V_{SS} $V_{OL} = 0.4V$	8		mA
I_{OH}	Output current ¹⁰ (Source)	$V_{IN} = V_{DD}$ or V_{SS} $V_{OH} = V_{DD} - 0.4V$	-8		mA
P_{total}	Power dissipation ^{2,8,9}	$C_L = 50pF$		1.9	mW/ MHz
I_{DDQ}	Quiescent Supply Current	$V_{DD} = 5.5V$		10	μA
ΔI_{DDQ}	Quiescent Supply Current Delta ACTS	For input under test $V_{IN} = V_{DD} - 2.1V$ For all other inputs $V_{IN} = V_{DD}$ or V_{SS} $V_{DD} = 5.5V$		1.6	mA
C_{IN}	Input capacitance ⁵	$f = 1MHz @ 0V$		15	pF
C_{OUT}	Output capacitance ⁵	$f = 1MHz @ 0V$		15	pF

UT54ACS164/UT54ACTS164

Notes:

1. Functional tests are conducted in accordance with MIL-STD-883 with the following input test conditions: $V_{IH} = V_{IH(min)} + 20\%$, $- 0\%$; $V_{IL} = V_{IL(max)} + 0\%$, $- 50\%$, as specified herein, for TTL, CMOS, or Schmitt compatible inputs. Devices may be tested using any input voltage within the above specified range, but are guaranteed to $V_{IH(min)}$ and $V_{IL(max)}$.
2. Supplied as a design limit but not guaranteed or tested.
3. Per MIL-PRF-38535, for current density $\leq 5.0E5$ amps/cm², the maximum product of load capacitance (per output buffer) times frequency should not exceed 3,765 pF/MHz.
4. Not more than one output may be shorted at a time for maximum duration of one second.
5. Capacitance measured for initial qualification and when design changes may affect the value. Capacitance is measured between the designated terminal and V_{SS} at frequency of 1MHz and a signal amplitude of 50mV rms maximum.
6. Maximum allowable relative shift equals 50mV.
7. All specifications valid for radiation dose $\leq 1E6$ rads(Si).
8. Power does not include power contribution of any TTL output sink current
9. Power dissipation specified per switching output.
10. This value is guaranteed based on characterization data, but not tested.

AC ELECTRICAL CHARACTERISTICS ²(V_{DD} = 5.0V ±10%; V_{SS} = 0V ¹, -55 °C < T_C < +125°C)

SYMBOL	PARAMETER	MINIMUM	MAXIMUM	UNIT
t _{PHL}	CLK to Qn	4	21	ns
t _{PLH}	CLK to Qn	2	18	ns
t _{PHL}	$\overline{\text{CLR}}$ to Qn	5	21	ns
f _{MAX}	Maximum clock frequency		83	MHz
t _{SU1}	$\overline{\text{CLR}}$ inactive Setup time before CLK ↑	4		ns
t _{SU2}	Data setup time before CLK ↑	4		ns
t _H ³	Data hold time after CLK ↑	2		ns
t _W	Minimum pulse width $\overline{\text{CLR}}$ low CLK high CLK low	6		ns

Notes:

1. Maximum allowable relative shift equals 50mV.
2. All specifications valid for radiation dose ≤ 1E6 rads(Si).
3. Based on characterization, hold time (t_H) of 0ns can be assumed if data setup time (t_{SU2}) is ≥10ns. This is guaranteed, but not tested.

UT54ACS165/UT54ACTS165

Radiation-Hardened 8-Bit Parallel Shift Registers

FEATURES

- Complementary outputs
- Direct overriding load (data) inputs
- Gated clock inputs
- Parallel-to-serial data conversions
- 1.2μ radiation-hardened CMOS
 - Latchup immune
- High speed
- Low power consumption
- Single 5 volt supply
- Available QML Q or V processes
- Flexible package
 - 16-pin DIP
 - 16-lead flatpack

DESCRIPTION

The UT54ACS165 and the UT54ACTS165 are 8-bit serial shift registers that, when clocked, shift the data toward serial output Q_H . Parallel-in access to each stage is provided by eight individual data inputs that are enabled by a low level at the $\overline{SH/LD}$ input. The devices feature a clock inhibit function and a complemented serial output $\overline{Q_H}$.

Clocking is accomplished by a low-to-high transition of the CLK input while $\overline{SH/LD}$ is held high and CLK INH is held low. The functions of the CLK and CLK INH (clock inhibit) inputs are interchangeable. Since a low CLK input and a low-to-high transition of CLK INH will also accomplish clocking, CLK INH should be changed to the high level only while the CLK input is high. Parallel loading is disabled when $\overline{SH/LD}$ is held high. Parallel inputs to the registers are enabled while $\overline{SH/LD}$ is low independently of the levels of CLK, CLK INH or SER inputs.

The devices are characterized over full military temperature range of -55°C to +125 °C.

FUNCTION TABLE

INPUTS					INTERNAL OUTPUTS		OUTPUTS	
$\overline{SH/LD}$	CLK INH	CLK	SER	PARALLEL A . . . H	\overline{Q}_A	\overline{Q}_B	Q_H	\overline{Q}_H
L	X	X	X	a . . . h	a	b	h	h
H	L	L	X	X	Q_A	Q_B	Q_H	\overline{Q}_H
H	L	↑	H	X	H	Q_A	Q_G	\overline{Q}_G
H	L	↑	L	X	L	Q_A	Q_G	\overline{Q}_G
H	H	X	X	X	Q_A	Q_B	Q_H	\overline{Q}_H

Note:

1. Q_n = The state of the referenced output one setup time prior to the Low-to-High clock transition.

PINOUTS

16-Pin DIP Top View

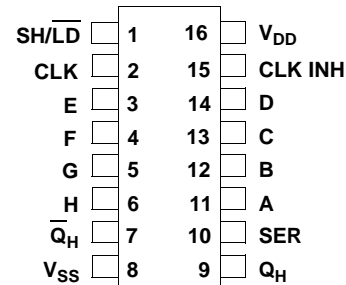

16-Lead Flatpack Top View

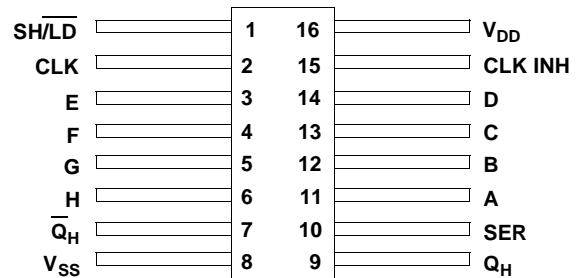

LOGIC SYMBOL

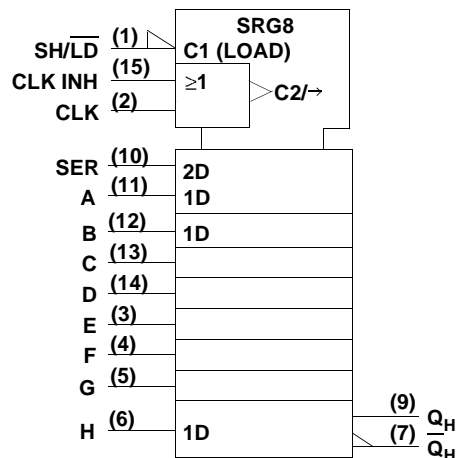

Note:

1. Logic symbol in accordance with ANSI/IEEE Std 91-1984 and IEC Publication 617-12.

LOGIC DIAGRAM

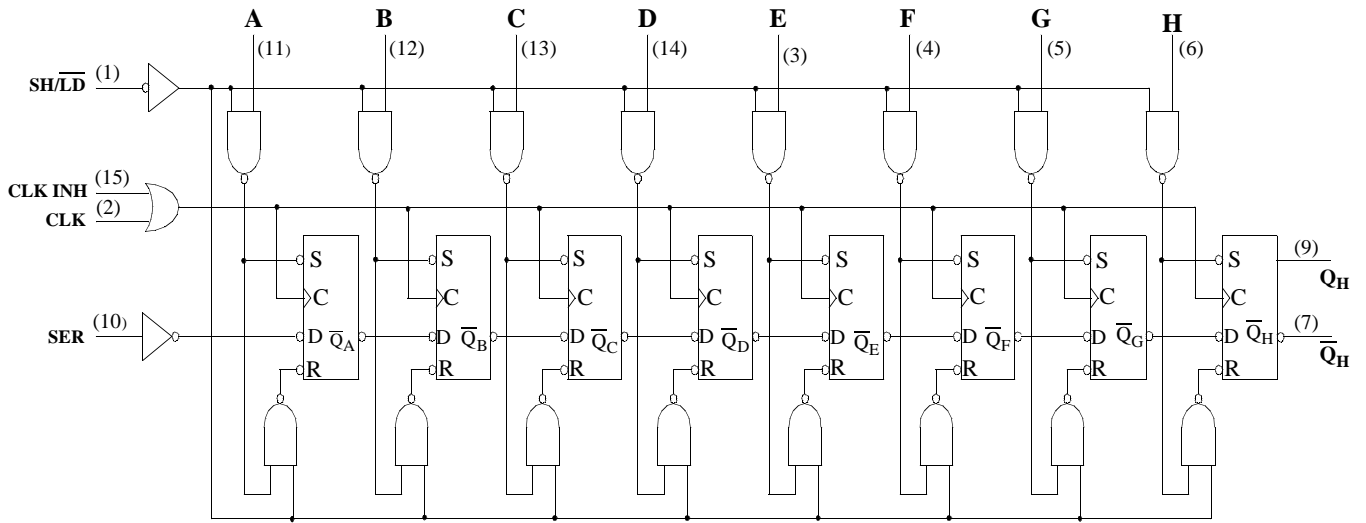

RADIATION HARDNESS SPECIFICATIONS ¹

PARAMETER	LIMIT	UNITS
Total Dose	1.0E6	rads(Si)
SEU Threshold ²	80	MeV-cm ² /mg
SEL Threshold	120	MeV-cm ² /mg
Neutron Fluence	1.0E14	n/cm ²

Notes:

1. Logic will not latchup during radiation exposure within the limits defined in the table.
2. Device storage elements are immune to SEU affects.

ABSOLUTE MAXIMUM RATINGS

SYMBOL	PARAMETER	LIMIT	UNITS
V_{DD}	Supply voltage	-0.3 to 7.0	V
$V_{I/O}$	Voltage any pin	-.3 to $V_{DD} + .3$	V
T_{STG}	Storage Temperature range	-65 to +150	°C
T_J	Maximum junction temperature	+175	°C
T_{LS}	Lead temperature (soldering 5 seconds)	+300	°C
Θ_{JC}	Thermal resistance junction to case	20	°C/W
I_I	DC input current	±10	mA
P_D	Maximum power dissipation	1	W

Note:

1. Stresses outside the listed absolute maximum ratings may cause permanent damage to the device. This is a stress rating only, functional operation of the device at these or any other conditions beyond limits indicated in the operational sections is not recommended. Exposure to absolute maximum rating conditions for extended periods may affect device reliability.

RECOMMENDED OPERATING CONDITIONS

SYMBOL	PARAMETER	LIMIT	UNITS
V_{DD}	Supply voltage	4.5 to 5.5	V
V_{IN}	Input voltage any pin	0 to V_{DD}	V
T_C	Temperature range	-55 to + 125	°C

DC ELECTRICAL CHARACTERISTICS ⁷(V_{DD} = 5.0V ±10%; V_{SS} = 0V ⁶, -55 °C < T_C < +125°C)

SYMBOL	PARAMETER	CONDITION	MIN	MAX	UNIT
V _{IL}	Low-level input voltage ¹ ACTS ACS			0.8 .3V _{DD}	V
V _{IH}	High-level input voltage ¹ ACTS ACS		.5V _{DD} .7V _{DD}		V
I _{IN}	Input leakage current ACTS/ACS	V _{IN} = V _{DD} or V _{SS}	-1	1	μA
V _{OL}	Low-level output voltage ³ ACTS ACS	I _{OL} = 8.0mA I _{OL} = 100μA		0.40 0.25	V
V _{OH}	High-level output voltage ³ ACTS ACS	I _{OH} = -8.0mA I _{OH} = -100μA	.7V _{DD} V _{DD} - 0.25		V
I _{OS}	Short-circuit output current ^{2,4} ACTS/ACS	V _O = V _{DD} and V _{SS}	-200	200	mA
I _{OL}	Output current ¹⁰ (Sink)	V _{IN} = V _{DD} or V _{SS} V _{OL} = 0.4V	8		mA
I _{OH}	Output current ¹⁰ (Source)	V _{IN} = V _{DD} or V _{SS} V _{OH} = V _{DD} - 0.4V	-8		mA
P _{total}	Power dissipation ^{2,8,9}	C _L = 50pF		2.9	mW/MHz
I _{DDQ}	Quiescent Supply Current	V _{DD} = 5.5V		10	μA
ΔI _{DDQ}	Quiescent Supply Current Delta ACTS	For input under test V _{IN} = V _{DD} - 2.1V For all other inputs V _{IN} = V _{DD} or V _{SS} V _{DD} = 5.5V		1.6	mA
C _{IN}	Input capacitance ⁵	f = 1MHz @ 0V		15	pF
C _{OUT}	Output capacitance ⁵	f = 1MHz @ 0V		15	pF

UT54ACS165/UT54ACTS165

Notes:

1. Functional tests are conducted in accordance with MIL-STD-883 with the following input test conditions: $V_{IH} = V_{IH(min)} + 20\%$, $- 0\%$; $V_{IL} = V_{IL(max)} + 0\%$, $- 50\%$, as specified herein, for TTL, CMOS, or Schmitt compatible inputs. Devices may be tested using any input voltage within the above specified range, but are guaranteed to $V_{IH(min)}$ and $V_{IL(max)}$.
2. Supplied as a design limit but not guaranteed or tested.
3. Per MIL-PRF-38535, for current density $\leq 5.0E5$ amps/cm², the maximum product of load capacitance (per output buffer) times frequency should not exceed 3,765 pF/MHz.
4. Not more than one output may be shorted at a time for maximum duration of one second.
5. Capacitance measured for initial qualification and when design changes may affect the value. Capacitance is measured between the designated terminal and V_{SS} at frequency of 1MHz and a signal amplitude of 50mV rms maximum.
6. Maximum allowable relative shift equals 50mV.
7. All specifications valid for radiation dose $\leq 1E6$ rads(Si).
8. Power does not include power contribution of any TTL output sink current.
9. Power dissipation specified per switching output.
10. This value is guaranteed based on characterization data, but not tested.

AC ELECTRICAL CHARACTERISTICS ²(V_{DD} = 5.0V ±10%; V_{SS} = 0V ¹, -55 °C < T_C < +125°C)

SYMBOL	PARAMETER	MINIMUM	MAXIMUM	UNIT
t _{PHL}	CLK or CLK INH to Q _H or \overline{Q}_H	2	21	ns
t _{PLH}	CLK or CLK INH to Q _H or \overline{Q}_H	2	18	ns
t _{PHL}	SH/ \overline{LD} to Q _H or \overline{Q}_H	2	21	ns
t _{PLH}	SH/ \overline{LD} to Q _H or \overline{Q}_H	2	18	ns
t _{PHL}	H to Q _H	2	21	ns
t _{PLH}	H to Q _H	2	17	ns
t _{PHL}	H to \overline{Q}_H	2	20	ns
t _{PLH}	H to \overline{Q}_H	2	18	ns
f _{MAX}	Maximum clock frequency		71	MHz
t _{SU1}	SER, SH/ \overline{LD} , CLKINH or CLK Setup time before CLK ↑ or CLK INH ↑	7		ns
t _{SU2}	Data setup time before SH/ \overline{LD}	7		ns
t _{H1}	SER hold time after CLK or CLK INH ↑	2		ns
t _{H2}	CLK INH hold time after CLK ↑	2		ns
t _{H3} ³	Hold time for any input after SH/ \overline{LD}	2		ns
t _w	Minimum pulse width CLK or CLK INH high CLK or CLK INH low SH/ \overline{LD}	7		ns

Notes:

1. Maximum allowable relative shift equals 50mV.

2. All specifications valid for radiation dose ≤ 1E6 rads(Si).

3. Based on characterization, hold time (t_{H3}) of 0ns for data pins A-H, can be assumed if data setup time (t_{SU2}) is ≥ 10ns. This is guaranteed, but not tested.

UT54ACS169/UT54ACTS169

Radiation-Hardened 4-Bit Up-Down Binary Counters

FEATURES

- Fully synchronous operation for counting and programming
- Internal look-ahead for fast counting
- Carry output for n-bit cascading
- Fully independent clock circuit
- 1.2 μ radiation-hardened CMOS
 - Latchup immune
- High speed
- Low power consumption
- Single 5 volt supply
- Available QML Q or V processes
- Flexible package
 - 16-pin DIP
 - 16-lead flatpack

DESCRIPTION

The UT54ACS169 and the UT54ACTS169 are synchronous 4-bit binary counters that feature an internal carry look-ahead for cascading in high-speed counting applications. Synchronous operation is provided by having all flip-flops clocked simultaneously so that the outputs change coincident with each other when instructed by the count-enable inputs and internal gating. Synchronous operation helps eliminate the output counting spikes that are normally associated with asynchronous (ripple clock) counters. The clock input triggers the four flip-flops on the rising (positive-going) edge of the clock.

The counters are fully programmable (i.e., the outputs may each be preset high or low). The load input circuitry allows loading with the carry-output of cascaded counters. Loading is synchronous; applying a low level at the load input disables the counter and causes the outputs to agree with the data inputs after the next clock pulse.

The carry look-ahead circuitry provides for cascaded counters for n-bit synchronous application without additional gating. Instrumental in accomplishing this function are two count-enable inputs and a carry output. Assert both count enable inputs ($\overline{\text{ENP}}$ and $\overline{\text{ENT}}$) to count. The direction of the count is determined by the level of the $\text{U}/\overline{\text{D}}$ input. When $\text{U}/\overline{\text{D}}$ is high, the counter counts up; when low, it counts down. Input $\overline{\text{ENT}}$ is fed forward to enable the carry output. The ripple carry output

$\overline{\text{RCO}}$ enables a low-level pulse while the count is zero (all inputs low) counting down or maximum (15) counting up. The low-level overflow carry pulse can be used to enable successive cascaded stages.

PINOUTS

16-Pin DIP

Top View

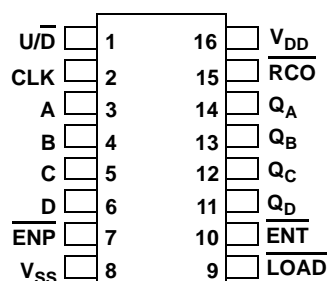

16-Lead Flatpack

Top View

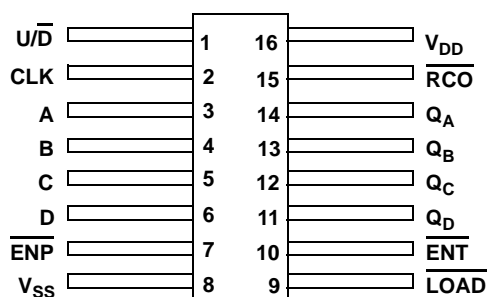

Transitions at $\overline{\text{ENP}}$ or $\overline{\text{ENT}}$ are allowed regardless of the level of the clock input.

The counters feature a fully independent clock circuit. Changes at control inputs ($\overline{\text{ENP}}$, $\overline{\text{ENT}}$, $\overline{\text{LOAD}}$, $\text{U}/\overline{\text{D}}$) that modify the operating mode have no effect on the contents of the counter until clocking occurs. The function of the counter (whether enabled, disabled, loading, or counting) will be dictated solely by the conditions meeting the stable setup and hold times.

The devices are characterized over full military temperature range of -55°C to +125°C.

LOGIC SYMBOL

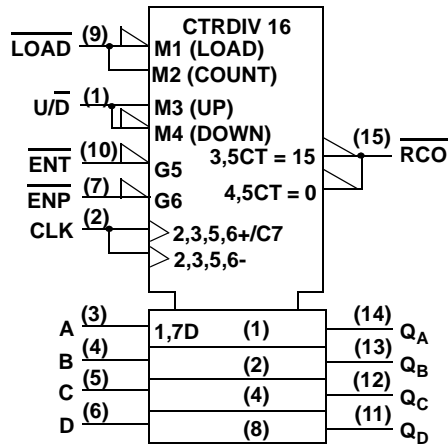

Note:

1. Logic symbol in accordance with ANSI/IEEE Std 91-1984 and IEC Publication 617-12.

FUNCTION TABLE

OUTPUT	$\overline{\text{LOAD}}$	$\overline{\text{ENP}}$	$\overline{\text{ENT}}$	$\text{U}/\overline{\text{D}}$	CLK
Count Up	H	L	L	H	↑
Count Down	H	L	L	L	↑
Load Preset	L	X	X	X	↑
Inhibit	H	H	X	X	X
	H	X	H	X	X

LOGIC DIAGRAM

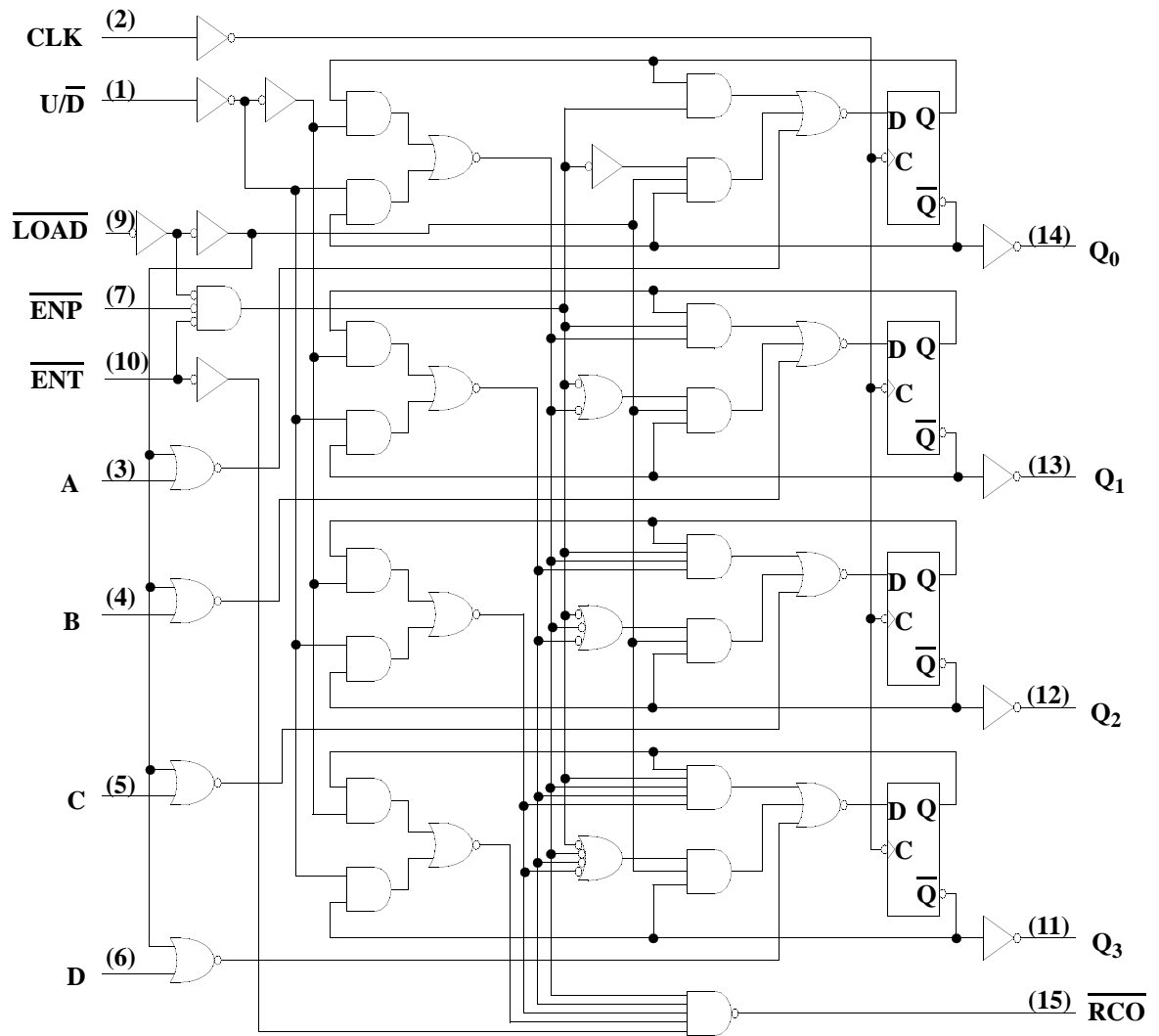

RADIATION HARDNESS SPECIFICATIONS ¹

PARAMETER	LIMIT	UNITS
Total Dose	1.0E6	rads(Si)
SEU Threshold ²	80	MeV-cm ² /mg
SEL Threshold	120	MeV-cm ² /mg
Neutron Fluence	1.0E14	n/cm ²

Notes:

- Logic will not latchup during radiation exposure within the limits defined in the table.
- Device storage elements are immune to SEU affects.

ABSOLUTE MAXIMUM RATINGS

SYMBOL	PARAMETER	LIMIT	UNITS
V _{DD}	Supply voltage	-0.3 to 7.0	V
V _{I/O}	Voltage any pin	-.3 to V _{DD} +.3	V
T _{STG}	Storage Temperature range	-65 to +150	°C
T _J	Maximum junction temperature	+175	°C
T _{LS}	Lead temperature (soldering 5 seconds)	+300	°C
Θ _{JC}	Thermal resistance junction to case	20	°C/W
I _I	DC input current	±10	mA
P _D	Maximum power dissipation	1	W

Note:

- Stresses outside the listed absolute maximum ratings may cause permanent damage to the device. This is a stress rating only, functional operation of the device at these or any other conditions beyond limits indicated in the operational sections is not recommended. Exposure to absolute maximum rating conditions for extended periods may affect device reliability.

RECOMMENDED OPERATING CONDITIONS

SYMBOL	PARAMETER	LIMIT	UNITS
V _{DD}	Supply voltage	4.5 to 5.5	V
V _{IN}	Input voltage any pin	0 to V _{DD}	V
T _C	Temperature range	-55 to + 125	°C

DC ELECTRICAL CHARACTERISTICS ⁷

($V_{DD} = 5.0V \pm 10\%$; $V_{SS} = 0V$ ⁶, $-55^{\circ}C < T_C < +125^{\circ}C$)

SYMBOL	PARAMETER	CONDITION	MIN	MAX	UNIT
V_{IL}	Low-level input voltage ¹ ACTS ACS			0.8 .3 V_{DD}	V
V_{IH}	High-level input voltage ¹ ACTS ACS		.5 V_{DD} .7 V_{DD}		V
I_{IN}	Input leakage current ACTS/ACS	$V_{IN} = V_{DD}$ or V_{SS}	-1	1	μA
V_{OL}	Low-level output voltage ³ ACTS ACS	$I_{OL} = 8.0mA$ $I_{OL} = 100\mu A$		0.40 0.25	V
V_{OH}	High-level output voltage ³ ACTS ACS	$I_{OH} = -8.0mA$ $I_{OH} = -100\mu A$.7 V_{DD} $V_{DD}-0.25$		V
I_{OS}	Short-circuit output current ^{2,4} ACTS/ACS	$V_O = V_{DD}$ and V_{SS}	-200	200	mA
I_{OL}	Output current ¹⁰ (Sink)	$V_{IN} = V_{DD}$ or V_{SS} $V_{OL} = 0.4V$	8		mA
I_{OH}	Output current ¹⁰ (Source)	$V_{IN} = V_{DD}$ or V_{SS} $V_{OH} = V_{DD} - 0.4V$	-8		mA
P_{total}	Power dissipation ^{2, 8, 9}	$C_L = 50pF$		2.3	mW/MHz
I_{DDQ}	Quiescent Supply Current	$V_{DD} = 5.5V$		10	μA
ΔI_{DDQ}	Quiescent Supply Current Delta ACTS	For input under test $V_{IN} = V_{DD} - 2.1V$ For all other inputs $V_{IN} = V_{DD}$ or V_{SS} $V_{DD} = 5.5V$		1.6	mA
C_{IN}	Input capacitance ⁵	$f = 1MHz @ 0V$		15	pF
C_{OUT}	Output capacitance ⁵	$f = 1MHz @ 0V$		15	pF

Notes:

- Functional tests are conducted in accordance with MIL-STD-883 with the following input test conditions: $V_{IH} = V_{IH(min)} + 20\%$, -0% ; $V_{IL} = V_{IL(max)} + 0\%$, -50% , as specified herein, for TTL, CMOS, or Schmitt compatible inputs. Devices may be tested using any input voltage within the above specified range, but are guaranteed to $V_{IH(min)}$ and $V_{IL(max)}$.
- Supplied as a design limit but not guaranteed or tested.
- Per MIL-PRF-38535, for current density $\leq 5.0E5$ amps/cm², the maximum product of load capacitance (per output buffer) times frequency should not exceed 3,765 pF/MHz.
- Not more than one output may be shorted at a time for maximum duration of one second.
- Capacitance measured for initial qualification and when design changes may affect the value. Capacitance is measured between the designated terminal and V_{SS} at frequency of 1MHz and a signal amplitude of 50mV rms maximum.
- Maximum allowable relative shift equals 50mV.
- All specifications valid for radiation dose $\leq 1E6$ rads(Si).
- Power does not include power contribution of any TTL output sink current.
- Power dissipation specified per switching output.
- This value is guaranteed based on characterization data, but not tested.

AC ELECTRICAL CHARACTERISTICS ²
 $(V_{DD} = 5.0V \pm 10\%; V_{SS} = 0V^1, -55^\circ C < T_C < +125^\circ C)$

SYMBOL	PARAMETER	MINIMUM	MAXIMUM	UNIT
t_{PLH}	CLK to \overline{RCO}	2	23	ns
t_{PHL}	CLK to \overline{RCO}	4	28	ns
t_{PLH}	CLK to any Q	4	24	ns
t_{PHL}	CLK to any Q	4	24	ns
t_{PLH}	\overline{ENT} to \overline{RCO}	1	15	ns
t_{PHL}	\overline{ENT} to \overline{RCO}	2	16	ns
t_{PLH}	U/\overline{D} to \overline{RCO}	2	16	ns
t_{PHL}	U/\overline{D} to \overline{RCO}	2	16	ns
f_{MAX}	Maximum clock frequency		71	MHz
t_{SU1}	A, B, C, D setup time before CLK \uparrow	9		ns
t_{SU2}	\overline{LOAD} , \overline{ENP} , \overline{ENT} , U/\overline{D} Setup time before CLK \uparrow	9		ns
t_{H1}	Data hold time after CLK \uparrow	2		ns
t_{H2}	All synchronous inputs hold time after CLK \uparrow	2		ns
t_W	Minimum pulse width CLK high CLK low	7		ns

Notes:

- Maximum allowable relative shift equals 50mV.
- All specifications valid for radiation dose $\leq 1E6$ rads(Si).
- Based on characterization, hold time (t_{H1}) of 0ns can be assumed if data setup time (t_{SU1}) is ≥ 10 ns. This is guaranteed, but not tested.

UT54ACS190/UT54ACTS190

Radiation-Hardened Synchronous 4-Bit Up-Down BCD Counters

FEATURES

- Single down/up count control line
- Look-ahead circuitry enhances speed of cascaded counters
- Fully synchronous in count modes
- Asynchronously presettable with load control
- 1.2μ radiation-hardened CMOS
 - Latchup immune
- High speed
- Low power consumption
- Single 5 volt supply
- Available QML Q or V processes
- Flexible package
 - 16-pin DIP
 - 16-lead flatpack

DESCRIPTION

The UT54ACS190 and the UT54ACTS190 are synchronous 4-bit reversible up-down BCD decade counters. Synchronous counting operation is provided by having all flip-flops clocked simultaneously so that the outputs change coincident with each other when so instructed. Synchronous operation eliminates the output counting spikes associated with asynchronous counters.

The outputs of the four flip-flops are triggered on a low-to-high-level transition of the clock input if the enable input ($\overline{\text{CTEN}}$) is low. A logic one applied to $\overline{\text{CTEN}}$ inhibits counting. The direction of the count is determined by the level of the down/up ($\overline{\text{D/U}}$) input. When $\overline{\text{D/U}}$ is low, the counter counts up and when $\overline{\text{D/U}}$ is high, it counts down.

The counters feature a fully independent clock circuit. Changes at control inputs ($\overline{\text{CTEN}}$ and $\overline{\text{D/U}}$) that will modify the operating mode have no effect on the contents of the counter until clocking occurs.

The counters are fully programmable. The outputs may be preset to either logic level by placing a low on the load input and entering the desired data at the data inputs. The output will change to agree with the data inputs independently of the level of the clock input. The asynchronous load allows counters to be used as modulo-N dividers by simply modifying the count length with the preset inputs.

If preset to an illegal state, the counter returns to a normal sequence in one or two counts.

PINOUTS

16-Pin DIP Top View

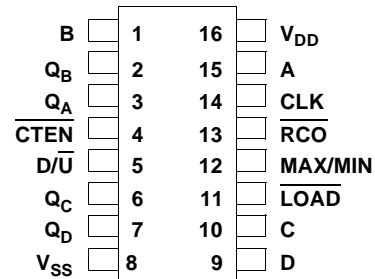

16-Lead Flatpack Top View

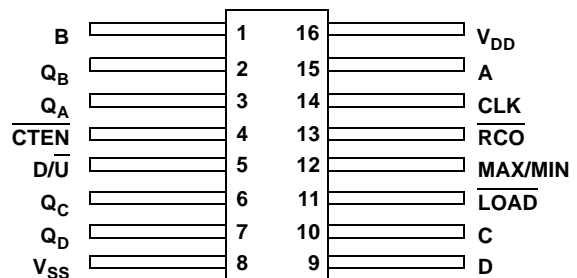

Two outputs have been made available to perform the cascading function: ripple clock and maximum/minimum (MAX/MIN) count. The MAX/MIN output produces a high-level output pulse with a duration approximately equal to one complete cycle of the clock while the count is zero (all outputs low) counting down or maximum (9) counting up.

The ripple clock output ($\overline{\text{RCO}}$) produces a low-level output pulse under those same conditions but only while the clock input is low. The counters easily cascade by feeding the $\overline{\text{RCO}}$ to the enable input of the succeeding counter if parallel clocking is used, or to the clock input if parallel enabling is used. Use the MAX/MIN count output to accomplish look-ahead for high-speed operation.

The devices are characterized over full military temperature range of -55°C to +125°C.

FUNCTION TABLE

Function	\overline{LOAD}	\overline{CTEN}	D/\overline{U}	CLK
Count up	H	L	L	↑
Count down	H	L	H	↑
Asynchronous	L	X		X
No change		H	X	

LOGIC SYMBOL

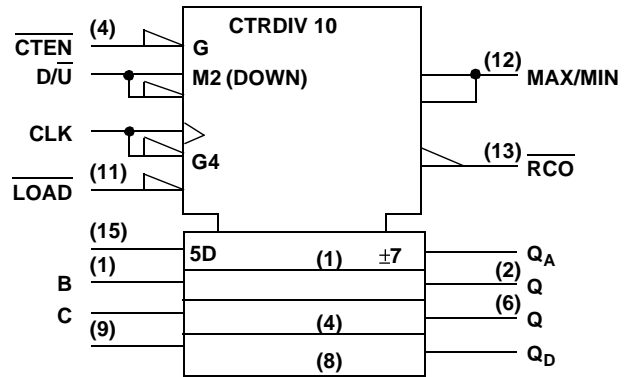

Note:
 1. Logic symbol in accordance with ANSI/IEEE standard 91-1984 and IEC Publication 617-12.

LOGIC DIAGRAM

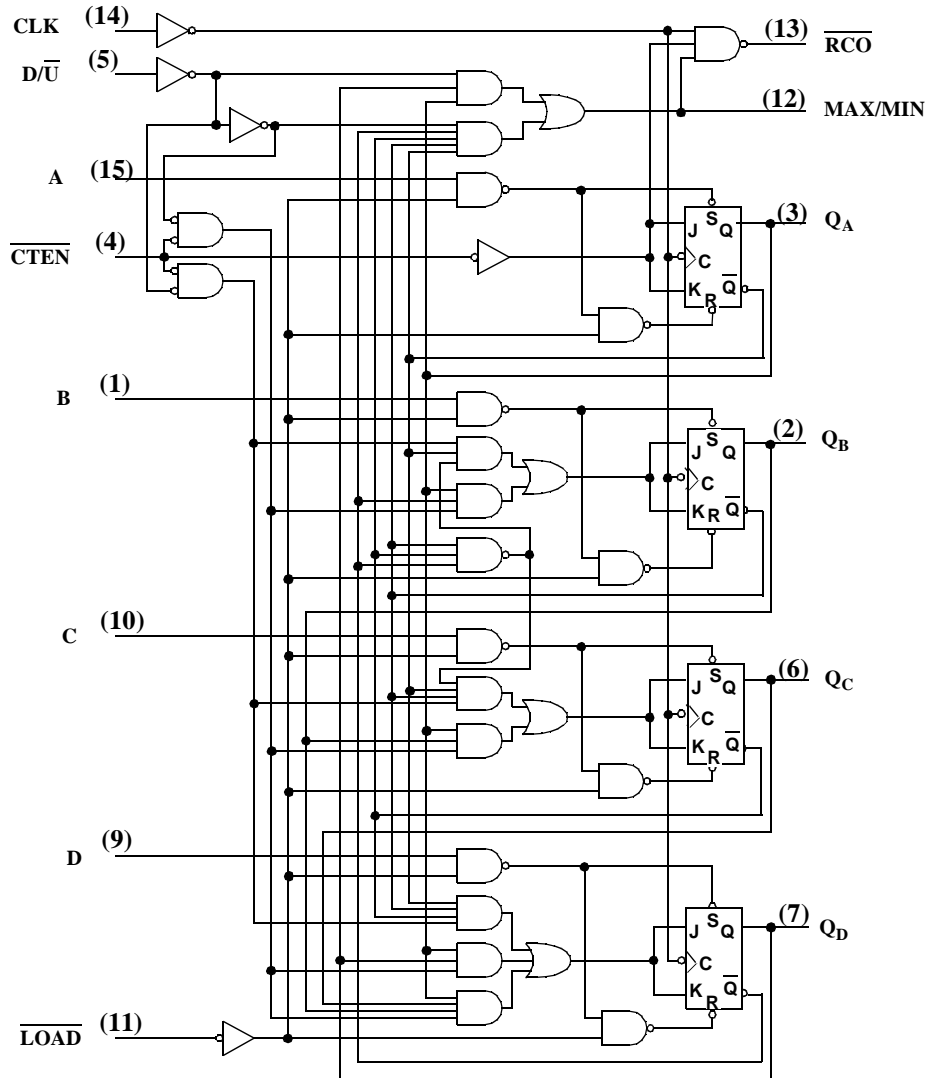

RADIATION HARDNESS SPECIFICATIONS ¹

PARAMETER	LIMIT	UNITS
Total Dose	1.0E6	rads(Si)
SEU Threshold ²	80	MeV-cm ² /mg
SEL Threshold	120	MeV-cm ² /mg
Neutron Fluence	1.0E14	n/cm ²

Notes:

1. Logic will not latchup during radiation exposure within the limits defined in the table.
2. Device storage elements are immune to SEU affects.

ABSOLUTE MAXIMUM RATINGS

SYMBOL	PARAMETER	LIMIT	UNITS
V _{DD}	Supply voltage	-0.3 to 7.0	V
V _{I/O}	Voltage any pin	-.3 to V _{DD} +.3	V
T _{STG}	Storage Temperature range	-65 to +150	°C
T _J	Maximum junction temperature	+175	°C
T _{LS}	Lead temperature (soldering 5 seconds)	+300	°C
Θ _{JC}	Thermal resistance junction to case	20	°C/W
I _I	DC input current	±10	mA
P _D	Maximum power dissipation	1	W

Note:

1. Stresses outside the listed absolute maximum ratings may cause permanent damage to the device. This is a stress rating only, functional operation of the device at these or any other conditions beyond limits indicated in the operational sections is not recommended. Exposure to absolute maximum rating conditions for extended periods may affect device reliability.

RECOMMENDED OPERATING CONDITIONS

SYMBOL	PARAMETER	LIMIT	UNITS
V _{DD}	Supply voltage	4.5 to 5.5	V
V _{IN}	Input voltage any pin	0 to V _{DD}	V
T _C	Temperature range	-55 to + 125	°C

DC ELECTRICAL CHARACTERISTICS ⁷(V_{DD} = 5.0V ±10%; V_{SS} = 0V ⁶, -55 °C < T_C < +125°C)

SYMBOL	PARAMETER	CONDITION	MIN	MAX	UNIT
V _{IL}	Low-level input voltage ¹ ACTS ACS			0.8 .3V _{DD}	V
V _{IH}	High-level input voltage ¹ ACTS ACS		.5V _{DD} .7V _{DD}		V
I _{IN}	Input leakage current ACTS/ACS	V _{IN} = V _{DD} or V _{SS}	-1	1	μA
V _{OL}	Low-level output voltage ³ ACTS ACS	I _{OL} = 8.0mA I _{OL} = 100μA		0.40 0.25	V
V _{OH}	High-level output voltage ³ ACTS ACS	I _{OH} = -8.0mA I _{OH} = -100μA	.7V _{DD} V _{DD} - 0.25		V
I _{OS}	Short-circuit output current ^{2,4} ACTS/ACS	V _O = V _{DD} and V _{SS}	-200	200	mA
I _{OL}	Output current ¹⁰ (Sink)	V _{IN} = V _{DD} or V _{SS} V _{OL} = 0.4V	8		mA
I _{OH}	Output current ¹⁰ (Source)	V _{IN} = V _{DD} or V _{SS} V _{OH} = V _{DD} - 0.4V	-8		mA
P _{total}	Power dissipation ^{2,8,9}	C _L = 50pF		2.2	mW/MHz
I _{DDQ}	Quiescent Supply Current	V _{DD} = 5.5V		10	μA
ΔI _{DDQ}	Quiescent Supply Current Delta ACTS	For input under test V _{IN} = V _{DD} - 2.1V For all other inputs V _{IN} = V _{DD} or V _{SS} V _{DD} = 5.5V		1.6	mA
C _{IN}	Input capacitance ⁵	f = 1MHz @ 0V		15	pF
C _{OUT}	Output capacitance ⁵	f = 1MHz @ 0V		15	pF

UT54ACS190/UT54ACTS190

Notes:

1. Functional tests are conducted in accordance with MIL-STD-883 with the following input test conditions: $V_{IH} = V_{IH(min)} + 20\%$, $- 0\%$; $V_{IL} = V_{IL(max)} + 0\%$, $- 50\%$, as specified herein, for TTL, CMOS, or Schmitt compatible inputs. Devices may be tested using any input voltage within the above specified range, but are guaranteed to $V_{IH(min)}$ and $V_{IL(max)}$.
2. Supplied as a design limit but not guaranteed or tested.
3. Per MIL-PRF-38535, for current density $\leq 5.0E5$ amps/cm², the maximum product of load capacitance (per output buffer) times frequency should not exceed 3,765 pF/MHz.
4. Not more than one output may be shorted at a time for maximum duration of one second.
5. Capacitance measured for initial qualification and when design changes may affect the value. Capacitance is measured between the designated terminal and V_{SS} at frequency of 1MHz and a signal amplitude of 50mV rms maximum.
6. Maximum allowable relative shift equals 50mV.
7. All specifications valid for radiation dose $\leq 1E6$ rads(Si).
8. Power does not include power contribution of any TTL output sink current.
9. Power dissipation specified per switching output.
10. This value is guaranteed based on characterization data, but not tested.

AC ELECTRICAL CHARACTERISTICS ²(V_{DD} = 5.0V ±10%; V_{SS} = 0V ¹, -55 °C < T_C < +125°C)

SYMBOL	PARAMETER	MINIMUM	MAXIMUM	UNIT
t _{PLH}	$\overline{\text{LOAD}}$ to Q _n	2	19	ns
t _{PHL}	$\overline{\text{LOAD}}$ to Q _n	2	22	ns
t _{PLH}	Data In to Q _n	2	19	ns
t _{PHL}	Data In to Q _n	2	21	ns
t _{PLH}	CLK to Q _n	2	18	ns
t _{PHL}	CLK to Q _n	2	20	ns
t _{PLH}	CLK to $\overline{\text{RCO}}$	2	16	ns
t _{PHL}	CLK to $\overline{\text{RCO}}$	2	16	ns
t _{PLH}	CLK to MAX/MIN	2	18	ns
t _{PHL}	CLK to MAX/MIN	2	23	ns
t _{PLH}	D/ $\overline{\text{U}}$ to $\overline{\text{RCO}}$	2	16	ns
t _{PHL}	D/ $\overline{\text{U}}$ to $\overline{\text{RCO}}$	2	18	ns
t _{PLH}	D/ $\overline{\text{U}}$ to MAX/MIN	1	14	ns
t _{PHL}	D/ $\overline{\text{U}}$ to MAX/MIN	2	18	ns
t _{PLH}	$\overline{\text{CTEN}}$ to $\overline{\text{RCO}}$	2	12	ns
t _{PHL}	$\overline{\text{CTEN}}$ to $\overline{\text{RCO}}$	2	16	ns
f _{MAX}	Maximum clock frequency		71	MHz
t _{SU1}	$\overline{\text{CTEN}}$, D/ $\overline{\text{U}}$ Setup time before CLK ↑	13		ns
t _{SU2}	$\overline{\text{LOAD}}$ Setup time before CLK ↑	2		ns
t _{SU3}	A, B, C, D setup time before $\overline{\text{LOAD}}$ ↑	7		ns
t _{H1}	$\overline{\text{CTEN}}$ and D/ $\overline{\text{U}}$ hold time after CLK ↑	2		ns
t _{H2} ³	A, B, C, D hold time after $\overline{\text{LOAD}}$ ↑	2		ns
t _w	Minimum pulse width CLK high CLK low $\overline{\text{LOAD}}$ low	7		ns

Notes:

1. Maximum allowable relative shift equals 50mV.
2. All specifications valid for radiation dose ≤ 1E6 rads(Si).
3. Based on characterization, hold time (t_{H2}) of 0ns can be assumed if data setup time (t_{SU3}) is ≥ 10ns. This is guaranteed, but not tested.

UT54ACS191/UT54ACTS191

Radiation-Hardened Synchronous 4-Bit Up-Down Binary Counters

FEATURES

- Single down/up count control line
- Look-ahead circuitry enhances speed of cascade counters
- Fully synchronous in count modes
- Asynchronously presettable with load control
- 1.2 μ radiation-hardened CMOS
 - Latchup immune
- High speed
- Low power consumption
- Single 5 volt supply
- Available QML Q or V processes
- Flexible package
 - 16-pin DIP
 - 16-lead flatpack

DESCRIPTION

The UT54ACS191 and the UT54ACTS191 are synchronous 4-bit reversible up-down binary counters. Synchronous counting operation is provided by having all flip-flops clocked simultaneously so that the outputs change coincident with each other when so instructed. Synchronous operation eliminates the output counting spikes associated with asynchronous counters.

The outputs of the four flip-flops are triggered on a low-to-high-level transition of the clock input if the enable input (\overline{CTEN}) is low. A logic one applied to \overline{CTEN} inhibits counting. The direction of the count is determined by the level of the down/up ($\overline{D/U}$) input. When $\overline{D/U}$ is low, the counter counts up and when $\overline{D/U}$ is high, it counts down.

The counters feature a fully independent clock circuit. Changes at control inputs (\overline{CTEN} and $\overline{D/U}$) that will modify the operating mode have no effect on the contents of the counter until clocking occurs.

The counters are fully programmable. The outputs may be preset to either logic level by placing a low on the load input and entering the desired data at the data inputs. The output will change to agree with the data inputs independently of the level of the clock input. The asynchronous load allows counters to be used as modulo-N dividers by simply modifying the count length with the preset inputs.

Two outputs have been made available to perform the cascading function: ripple clock and maximum/minimum (MAX/MIN) count. The MAX/MIN output produces a high-level output pulse with a duration approximately equal to one complete cycle of the clock while the count is zero (all outputs low) counting down or maximum (15) counting up.

PINOUTS

16-Pin DIP
Top View

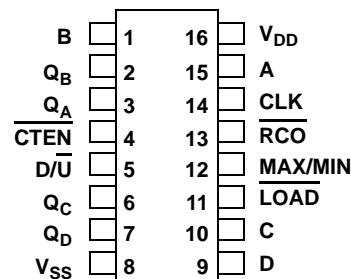

16-Lead Flatpack
Top View

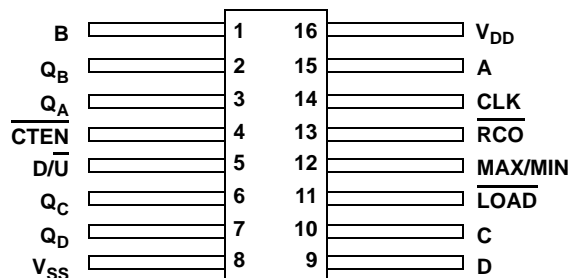

The ripple clock output (\overline{RCO}) produces a low-level output pulse under those same conditions but only while the clock input is low. The counters easily cascade by feeding the \overline{RCO} to the enable input of the succeeding counter if parallel clocking is used, or to the clock input if parallel enabling is used. Use the MAX/MIN count output to accomplish look-ahead for high-speed operation.

The devices are characterized over full military temperature range of -55°C to +125°C.

FUNCTION TABLE

FUNCTION	\overline{LOAD}	\overline{CTEN}	D/ \overline{U}	CLK
Count Up	H	L	L	↑
Count Down	H	L	H	↑
Asynchronous Reset	L	X	X	X
No Change	H	H	X	X

LOGIC SYMBOL

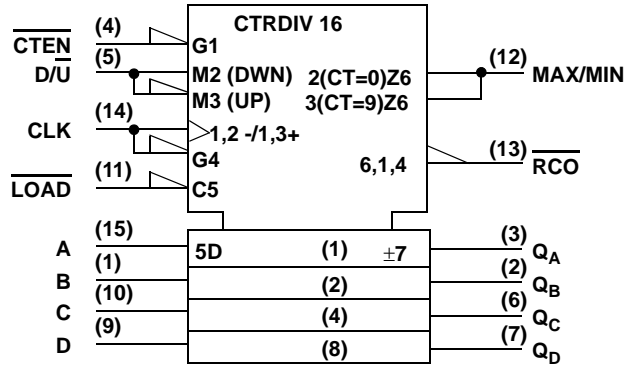

Note:

1. Logic symbol in accordance with ANSI/IEEE standard 91-1984 and IEC Publication 617-12.

LOGIC DIAGRAM

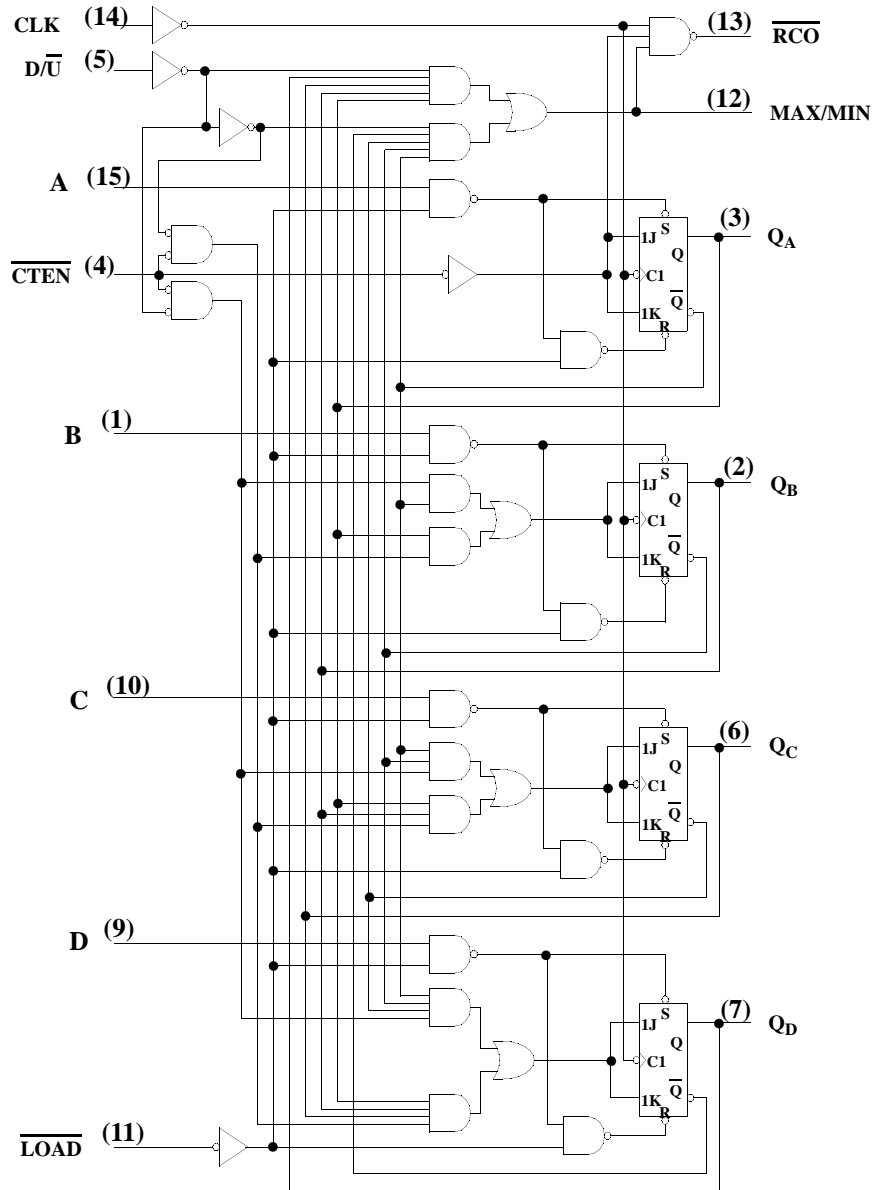

RADIATION HARDNESS SPECIFICATIONS ¹

PARAMETER	LIMIT	UNITS
Total Dose	1.0E6	rads(Si)
SEU Threshold ²	80	MeV-cm ² /mg
SEL Threshold	120	MeV-cm ² /mg
Neutron Fluence	1.0E14	n/cm ²

Notes:

1. Logic will not latchup during radiation exposure within the limits defined in the table.
2. Device storage elements are immune to SEU affects.

ABSOLUTE MAXIMUM RATINGS

SYMBOL	PARAMETER	LIMIT	UNITS
V _{DD}	Supply voltage	-0.3 to 7.0	V
V _{I/O}	Voltage any pin	-.3 to V _{DD} +.3	V
T _{STG}	Storage Temperature range	-65 to +150	°C
T _J	Maximum junction temperature	+175	°C
T _{LS}	Lead temperature (soldering 5 seconds)	+300	°C
Θ _{JC}	Thermal resistance junction to case	20	°C/W
I _I	DC input current	±10	mA
P _D	Maximum power dissipation	1	W

Note:

1. Stresses outside the listed absolute maximum ratings may cause permanent damage to the device. This is a stress rating only, functional operation of the device at these or any other conditions beyond limits indicated in the operational sections is not recommended. Exposure to absolute maximum rating conditions for extended periods may affect device reliability.

RECOMMENDED OPERATING CONDITIONS

SYMBOL	PARAMETER	LIMIT	UNITS
V _{DD}	Supply voltage	4.5 to 5.5	V
V _{IN}	Input voltage any pin	0 to V _{DD}	V
T _C	Temperature range	-55 to + 125	°C

DC ELECTRICAL CHARACTERISTICS ⁷(V_{DD} = 5.0V ±10%; V_{SS} = 0V ⁶, -55°C < T_C < +125°C)

SYMBOL	PARAMETER	CONDITION	MIN	MAX	UNIT
V _{IL}	Low-level input voltage ¹ ACTS ACS			0.8 .3V _{DD}	V
V _{IH}	High-level input voltage ¹ ACTS ACS		.5V _{DD} .7V _{DD}		V
I _{IN}	Input leakage current ACTS/ACS	V _{IN} = V _{DD} or V _{SS}	-1	1	μA
V _{OL}	Low-level output voltage ³ ACTS ACS	I _{OL} = 8.0mA I _{OL} = 100μA		0.40 0.25	V
V _{OH}	High-level output voltage ³ ACTS ACS	I _{OH} = -8.0mA I _{OH} = -100μA	.7V _{DD} V _{DD} - 0.25		V
I _{OS}	Short-circuit output current ^{2,4} ACTS/ACS	V _O = V _{DD} and V _{SS}	-200	200	mA
I _{OL}	Output current ¹⁰ (Sink)	V _{IN} = V _{DD} or V _{SS} V _{OL} = 0.4V	8		mA
I _{OH}	Output current ¹⁰ (Source)	V _{IN} = V _{DD} or V _{SS} V _{OH} = V _{DD} - 0.4V	-8		mA
P _{total}	Power dissipation ^{2, 8, 9}	C _L = 50pF		2.1	mW/ MHz
I _{DDQ}	Quiescent Supply Current	V _{DD} = 5.5V		10	μA
ΔI _{DDQ}	Quiescent Supply Current Delta ACTS	For input under test V _{IN} = V _{DD} - 2.1V For all other inputs V _{IN} = V _{DD} or V _{SS} V _{DD} = 5.5V		1.6	mA
C _{IN}	Input capacitance ⁵	f = 1MHz @ 0V		15	pF
C _{OUT}	Output capacitance ⁵	f = 1MHz @ 0V		15	pF

UT54ACS191/UT54ACTS191

Notes:

1. Functional tests are conducted in accordance with MIL-STD-883 with the following input test conditions: $V_{IH} = V_{IH(min)} + 20\%$, $- 0\%$; $V_{IL} = V_{IL(max)} + 0\%$, $- 50\%$, as specified herein, for TTL, CMOS, or Schmitt compatible inputs. Devices may be tested using any input voltage within the above specified range, but are guaranteed to $V_{IH(min)}$ and $V_{IL(max)}$.
2. Supplied as a design limit but not guaranteed or tested.
3. Per MIL-PRF-38535, for current density $\leq 5.0E5$ amps/cm², the maximum product of load capacitance (per output buffer) times frequency should not exceed 3,765 pF/MHz.
4. Not more than one output may be shorted at a time for maximum duration of one second.
5. Capacitance measured for initial qualification and when design changes may affect the value. Capacitance is measured between the designated terminal and V_{SS} at frequency of 1MHz and a signal amplitude of 50mV rms maximum.
6. Maximum allowable relative shift equals 50mV.
7. All specifications valid for radiation dose $\leq 1E6$ rads(Si).
8. Power does not include power contribution of any TTL output sink current.
9. Power dissipation specified per switching output.
10. This value is guaranteed based on characterization data, but not tested.

AC ELECTRICAL CHARACTERISTICS ²(V_{DD} = 5.0V ±10%; V_{SS} = 0V ¹, -55°C < T_C < +125°C)

SYMBOL	PARAMETER	MINIMUM	MAXIMUM	UNIT
t _{PLH}	$\overline{\text{LOAD}}$ to Q _n	2	20	ns
t _{PHL}	$\overline{\text{LOAD}}$ to Q _n	2	22	ns
t _{PLH}	Data In to Q _n	2	23	ns
t _{PHL}	Data In to Q _n	2	19	ns
t _{PLH}	CLK to Q _n	2	17	ns
t _{PHL}	CLK to Q _n	2	22	ns
t _{PLH}	CLK to $\overline{\text{RCO}}$	2	12	ns
t _{PHL}	CLK to $\overline{\text{RCO}}$	2	15	ns
t _{PLH}	CLK to MAX/MIN	2	22	ns
t _{PHL}	CLK to MAX/MIN	2	23	ns
t _{PLH}	D/ $\overline{\text{U}}$ to $\overline{\text{RCO}}$	2	16	ns
t _{PHL}	D/ $\overline{\text{U}}$ to $\overline{\text{RCO}}$	2	18	ns
t _{PLH}	D/ $\overline{\text{U}}$ to MAX/MIN	2	15	ns
t _{PHL}	D/ $\overline{\text{U}}$ to MAX/MIN	2	17	ns
t _{PLH}	$\overline{\text{CTEN}}$ to $\overline{\text{RCO}}$	2	12	ns
t _{PHL}	$\overline{\text{CTEN}}$ to $\overline{\text{RCO}}$	2	16	ns
f _{MAX}	Maximum clock frequency		63	MHz
t _{SU1}	$\overline{\text{LOAD}}$, $\overline{\text{CTEN}}$, D/ $\overline{\text{U}}$ Setup time before CLK ↑	12		ns
t _{SU2}	A, B, C, D setup time before $\overline{\text{LOAD}}$ ↑	5		ns
t _{H1}	$\overline{\text{CTEN}}$ and D/ $\overline{\text{U}}$ hold time after CLK ↑	2		ns
t _{H2} ³	A, B, C, D hold time after $\overline{\text{LOAD}}$ ↑	2		ns
t _W	Minimum pulse width CLK high CLK low $\overline{\text{LOAD}}$ low	8		ns

Notes:

1. Maximum allowable relative shift equals 50mV.
2. All specifications valid for radiation dose ≤ 1E6 rads(Si).
3. Based on characterization, hold time (t_{H2}) of 0ns can be assumed if data setup time (t_{SU2}) is ≥10ns. This is guaranteed, but not tested.

UT54ACS193/UT54ACTS193

Radiation-Hardened Synchronous 4-Bit Up-Down Dual Clock Counters

FEATURES

- Look-ahead circuitry enhances cascaded counters
- Fully synchronous in count modes
- Parallel asynchronous load for modulo-N count lengths
- Asynchronous clear
- 1.2 μ m radiation-hardened CMOS (ACTS193) and .6 μ m CRH CMOS process (ACS193)
 - Latchup immune
- High speed
- Low power consumption
- Single 5 volt supply
- Available QML Q or V processes
- Flexible package
 - 16-pin DIP
 - 16-lead flatpack

DESCRIPTION

The UT54ACS193 and the UT54ACTS193 are synchronous 4-bit, binary reversible up-down binary counters. Synchronous operation is provided by having all flip-flops clocked simultaneously so that the outputs change coincident with each other when instructed. Synchronous operation eliminates the output counting spikes normally associated with asynchronous counters.

The outputs of the four flip-flops are triggered on a low-to-high level transition of either count input (Up or Down). The direction of the counting is determined by which count input is pulsed while the other count input is high.

The counters are fully programmable. The outputs may be preset to either level by placing a low on the load input and entering the desired data at the data inputs. The output will change to agree with the data inputs independently of the count pulses. Asynchronous loading allows the counters to be used as modulo-N dividers by simply modifying the count length with the preset inputs.

A clear input has been provided that forces all outputs to the low level when a high level is applied. The clear function is independent of the count and the load inputs.

The counter is designed for efficient cascading without the need for external circuitry. The borrow output (\overline{BO}) produces a low-level pulse while the count is zero and the down input is low. Similarly, the carry output (\overline{CO}) produces a low-level pulse while the count is maximum

PINOUTS

16-Pin DIP
Top View

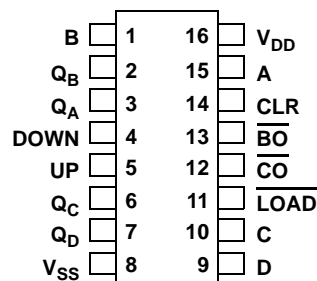

16-Lead Flatpack
Top View

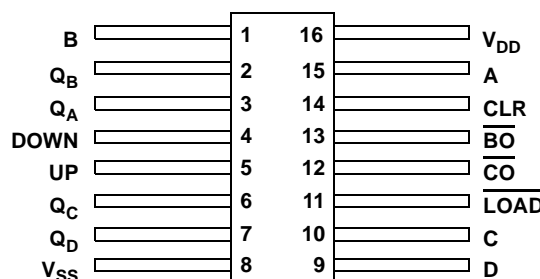

FUNCTION TABLE

FUNCTION	CLOCK UP	CLOCK DOWN	CLR	\overline{LOAD}
Count Up	↑	H	L	H
Count Down	H	↑	L	H
Reset	X	X	H	X
Load Preset Input	X	X	L	L

LOGIC SYMBOL

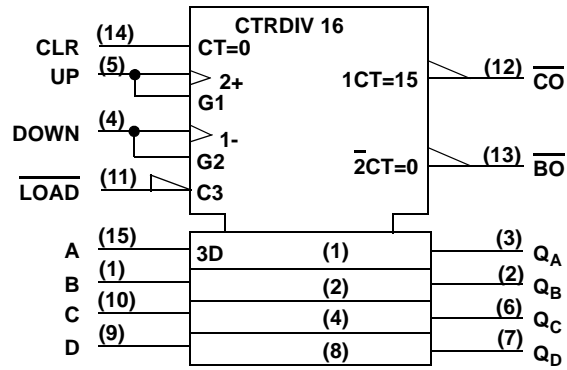

Note:

1. Logic symbol in accordance with ANSI/IEEE Std 91-1984 and IEC Publication 617-12.

LOGIC DIAGRAM

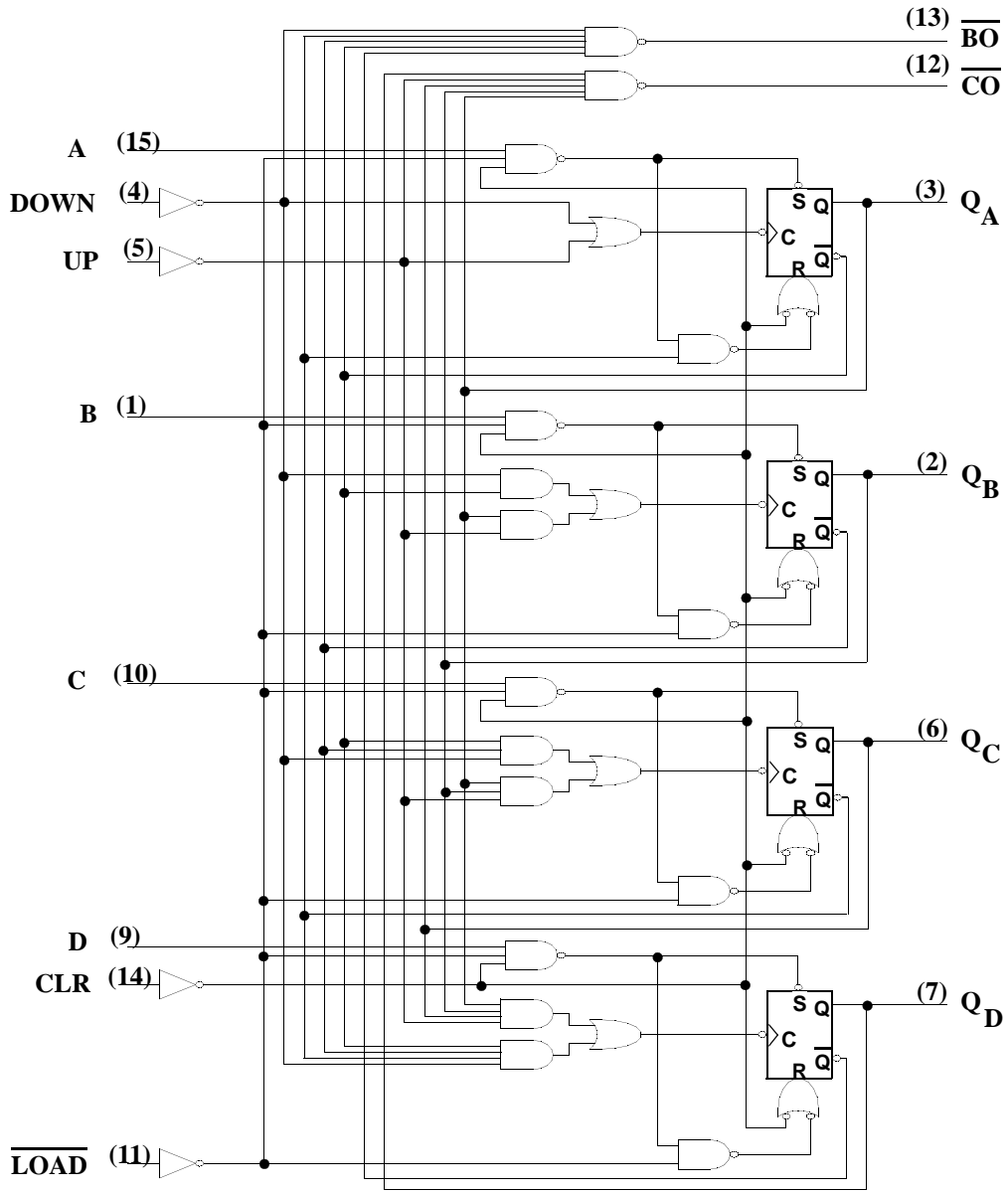

RADIATION HARDNESS SPECIFICATIONS ¹

PARAMETER	LIMIT	UNITS
Total Dose	1.0E6	rads(Si)
SEU Threshold ²	80	MeV-cm ² /mg
SEL Threshold	120	MeV-cm ² /mg
Neutron Fluence	1.0E14	n/cm ²

Notes:

1. Logic will not latchup during radiation exposure within the limits defined in the table.
2. Device storage elements are immune to SEU affects.

ABSOLUTE MAXIMUM RATINGS

SYMBOL	PARAMETER	LIMIT	UNITS
V _{DD}	Supply voltage	-0.3 to 7.0	V
V _{I/O}	Voltage any pin	-.3 to V _{DD} +.3	V
T _{STG}	Storage Temperature range	-65 to +150	°C
T _J	Maximum junction temperature	+175	°C
T _{LS}	Lead temperature (soldering 5 seconds)	+300	°C
Θ _{JC}	Thermal resistance junction to case	20	°C/W
I _I	DC input current	±10	mA
P _D	Maximum power dissipation	1	W

Note:

1. Stresses outside the listed absolute maximum ratings may cause permanent damage to the device. This is a stress rating only, functional operation of the device at these or any other conditions beyond limits indicated in the operational sections is not recommended. Exposure to absolute maximum rating conditions for extended periods may affect device reliability.

RECOMMENDED OPERATING CONDITIONS

SYMBOL	PARAMETER	LIMIT	UNITS
V_{DD}	Supply voltage	4.5 to 5.5	V
V_{IN}	Input voltage any pin	0 to V_{DD}	V
T_C	Temperature range	-55 to + 125	°C

DC ELECTRICAL CHARACTERISTICS ⁷(V_{DD} = 5.0V ±10%; V_{SS} = 0V ⁶, -55°C < T_C < +125°C)

SYMBOL	PARAMETER	CONDITION	MIN	MAX	UNIT
V _{IL}	Low-level input voltage ¹ ACTS ACS			0.8 .3V _{DD}	V
V _{IH}	High-level input voltage ¹ ACTS ACS		.5V _{DD} .7V _{DD}		V
I _{IN}	Input leakage current ACTS/ACS	V _{IN} = V _{DD} or V _{SS}	-1	1	μA
V _{OL}	Low-level output voltage ³ ACTS ACS	I _{OL} = 8.0mA I _{OL} = 100μA		0.40 0.25	V
V _{OH}	High-level output voltage ³ ACTS ACS	I _{OH} = -8.0mA I _{OH} = -100μA	.7V _{DD} V _{DD} - 0.25		V
I _{OS}	Short-circuit output current ^{2,4} ACTS/ACS	V _O = V _{DD} and V _{SS}	-200	200	mA
I _{OL}	Output current ¹⁰ (Sink)	V _{IN} = V _{DD} or V _{SS} V _{OL} = 0.4V	8		mA
I _{OH}	Output current ¹⁰ (Source)	V _{IN} = V _{DD} or V _{SS} V _{OH} = V _{DD} - 0.4V	-8		mA
P _{total}	Power dissipation ^{2, 8, 9}	C _L = 50pF		2.1	mW/ MHz
I _{DDQ}	Quiescent Supply Current	V _{DD} = 5.5V		10	μA
ΔI _{DDQ}	Quiescent Supply Current Delta ACTS	For input under test V _{IN} = V _{DD} - 2.1V For all other inputs V _{IN} = V _{DD} or V _{SS} V _{DD} = 5.5V		1.6	mA
C _{IN}	Input capacitance ⁵	f = 1MHz @ 0V		15	pF
C _{OUT}	Output capacitance ⁵	f = 1MHz @ 0V		15	pF

UT54ACS193/UT54ACTS193

Notes:

1. Functional tests are conducted in accordance with MIL-STD-883 with the following input test conditions: $V_{IH} = V_{IH(min)} + 20\%$, $- 0\%$; $V_{IL} = V_{IL(max)} + 0\%$, $- 50\%$, as specified herein, for TTL, CMOS, or Schmitt compatible inputs. Devices may be tested using any input voltage within the above specified range, but are guaranteed to $V_{IH(min)}$ and $V_{IL(max)}$.
2. Supplied as a design limit but not guaranteed or tested.
3. Per MIL-PRF-38535, for current density $\leq 5.0E5$ amps/cm², the maximum product of load capacitance (per output buffer) times frequency should not exceed 3,765 pF/MHz.
4. Not more than one output may be shorted at a time for maximum duration of one second.
5. Capacitance measured for initial qualification and when design changes may affect the value. Capacitance is measured between the designated terminal and V_{SS} at frequency of 1MHz and a signal amplitude of 50mV rms maximum.
6. Maximum allowable relative shift equals 50mV.
7. All ACTS specifications are valid for radiation dose $\leq 1E6$ rads(Si) and all ACS specifications are valid for radiation dose $\leq 5E5$ rads(Si).
8. Power does not include power contribution of any TTL output sink current.
9. Power dissipation specified per switching output.
10. This value is guaranteed based on characterization data, but not tested.

AC ELECTRICAL CHARACTERISTICS ²(V_{DD} = 5.0V ±10%; V_{SS} = 0V ¹, -55°C < T_C < +125°C)

SYMBOL	PARAMETER	MINIMUM	MAXIMUM	UNIT
t _{PLH}	UP to Q _n	2	20	ns
t _{PHL}	UP to Q _n	2	24	ns
t _{PLH}	UP to \overline{CO}	2	13	ns
t _{PHL}	UP to \overline{CO}	2	16	ns
t _{PLH}	DOWN to \overline{BO}	2	13	ns
t _{PHL}	DOWN to \overline{BO}	2	16	ns
t _{PLH}	DOWN to Q _n	2	20	ns
t _{PHL}	DOWN to Q _n	2	24	ns
t _{PLH}	\overline{LOAD} to Q _n	2	22	ns
t _{PHL}	\overline{LOAD} to Q _n	2	23	ns
t _{PHL}	CLR to Q _n	2	22	ns
f _{MAX}	Maximum clock frequency		56	MHz
t _{SU1}	\overline{LOAD} inactive setup time before UP or DOWN ↑	3		ns
t _{SU2}	CLR inactive setup time before UP or DOWN ↑	3		ns
t _{SU3}	A, B, C, D setup time before \overline{LOAD} ↑	6		ns
t _{H1}	UP high hold time after DOWN ↑	20		ns
t _{H2}	DOWN high hold time after UP ↑	20		ns
t _{H3} ³	A, B, C, D hold time after \overline{LOAD} ↑	2		ns
t _W	Minimum pulse width UP high or low DOWN high or low \overline{LOAD} low CLR high	9		ns

Notes:

1. Maximum allowable relative shift equals 50mV.
2. All ACTS specifications are valid for radiation dose ≤ 1E6 rads(Si) and all ACS specifications are valid for radiation dose ≤ 5E5 rads(Si).
3. Based on characterization, data hold time (t_{H3}) of 0ns can be assumed if data setup time (t_{SU3}) is ≥ 10ns. This is guaranteed, but not tested.

UT54ACTS220

Clock and Wait-State Generation Circuit

FEATURES

- 1.2 μ radiation-hardened CMOS
 - Latchup immune
- High speed
- Low power consumption
- Single 5-volt supply
- Available QML Q or V processes
- Flexible package
 - 14-pin DIP
 - 14-lead flatpack

DESCRIPTION

The UT54ACTS220 is designed to be a companion chip to UTMIC's UT69151 S μ MMIT family for the purpose of generating clock and wait-state signals. The device contains a divide by two circuit that accepts TTL input levels and drives CMOS output buffers. The chip accepts a 48MHz clock and generates a 24MHz clock. The 48MHz clock can have a duty cycle that varies by $\pm 20\%$. The UT54ACT220 generates a 24MHz clock with a $\pm 5\%$ duty cycle variation. The wait-state circuit generates a single wait-state by delaying the falling edge of \overline{DTACK} into the S μ MMIT. The clock/timing device generates \overline{DTACK} from the falling edge of input \overline{RCS} which is synchronized by the falling edge of 24MHz. The S μ MMIT drives inputs \overline{RCS} and \overline{DMACK} .

The devices are characterized over full military temperature range of -55°C to +125°C.

LOGIC SYMBOL

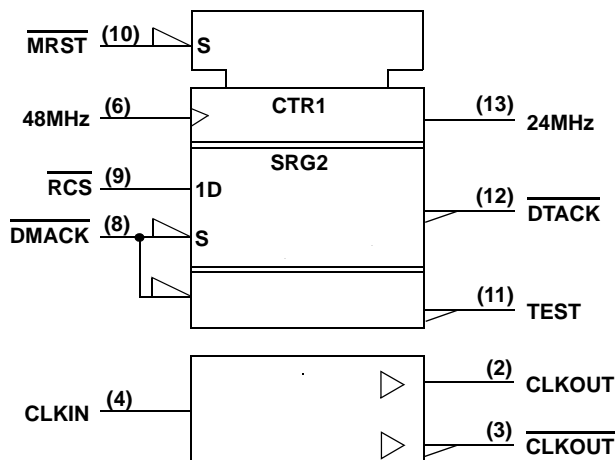

Note:
1. Logic symbol in accordance with ANSI/IEEE Std 91-1984 and IEC Publication 617-12.

PINOUTS

14-Pin DIP
Top View

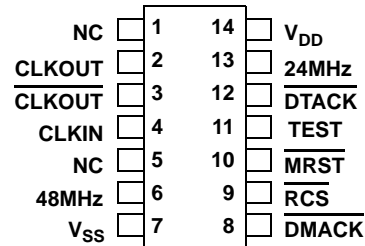

14-Lead Flatpack
Top View

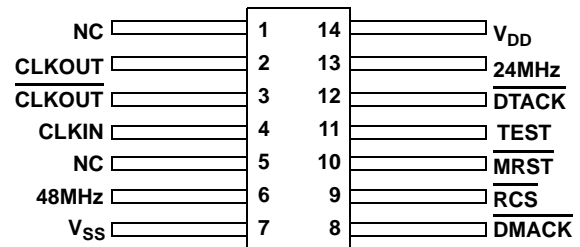

PIN DESCRIPTION

Pin Number	Pin Name	Description
2	CLKOUT	Buffered version of CLKIN.
3	$\overline{\text{CLKOUT}}$	Inverted version of CLKIN.
4	CLKIN	Clock Input. This signal can be any arbitrary signal that the user wishes to buffer.
6	48MHz	48MHz Clock. The 24MHz clock is created by dividing this signal by two.
8	$\overline{\text{DMACK}}$	DMA Acknowledge. This input is generated by the S μ MMIT. When high, this signal will cause $\overline{\text{DTACK}}$ output to be forced high.
9	$\overline{\text{RCS}}$	RAM Chip Select. This input is generated by the S μ MMIT.
10	$\overline{\text{MRST}}$	Master Reset. This input can be used to preset 24MHz, $\overline{\text{DTACK}}$ and TEST. For normal operation tie MRST to V _{DD} through a resistor.
11	TEST	Test output signal.
12	$\overline{\text{DTACK}}$	Data Transfer Acknowledge. This signal can be used to drive the $\overline{\text{DTACK}}$ signal of the S μ MMIT if the user requires one wait state during the memory transfer.
13	24MHz	24MHz Clock. This output runs at half the frequency of the 48MHz input. The falling edge of 24MHz is the signal that latches the DTACK outputs. 24MHz is forced high whenever MRST is low. Properly loaded, 24MHz will have a 50% duty cycle \pm 5%.

FUNCTIONAL TIMING: Single S μ MMIT Wait-State

For both read and write memory cycles, $\overline{\text{DTACK}}$ is an input to the S μ MMIT E and S μ MMIT LXE/DXE. A non-wait state memory requires two clock cycles, T_1 and T_2 of figure 1. For accessing slower memory devices, the UT54ACTS220 holds $\overline{\text{DTACK}}$ to a logical "1". This results in the stretching of memory cycles by one clock to three clock cycles, T_W of figure 1. The S μ MMIT E and S μ MMIT LXE/DXE samples the $\overline{\text{DTACK}}$ on the rising edge of the 24 MHz clock. If $\overline{\text{DTACK}}$ is not generated before the rising edge of the clock, the S μ MMIT E and S μ MMIT LXE/DXE extends the memory cycle.

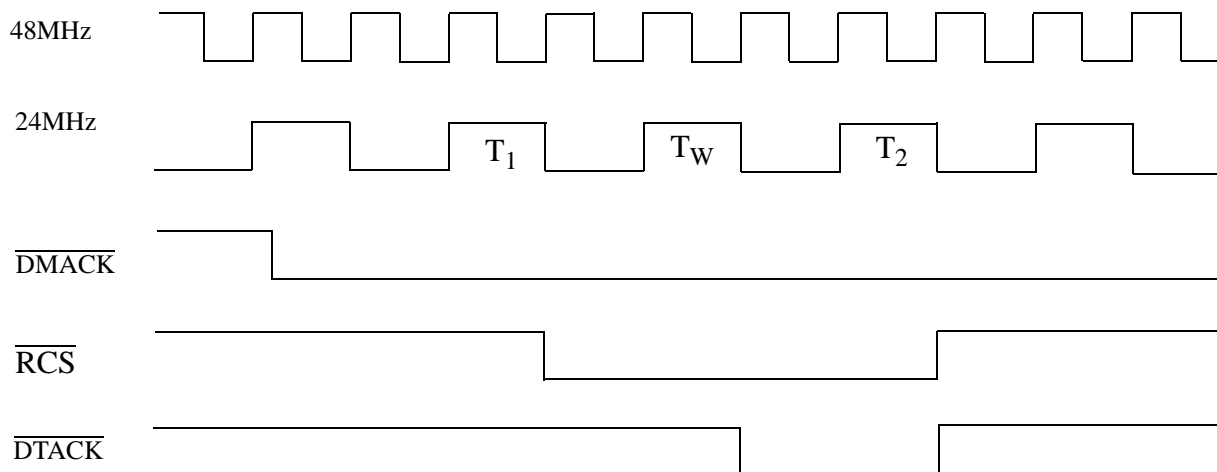
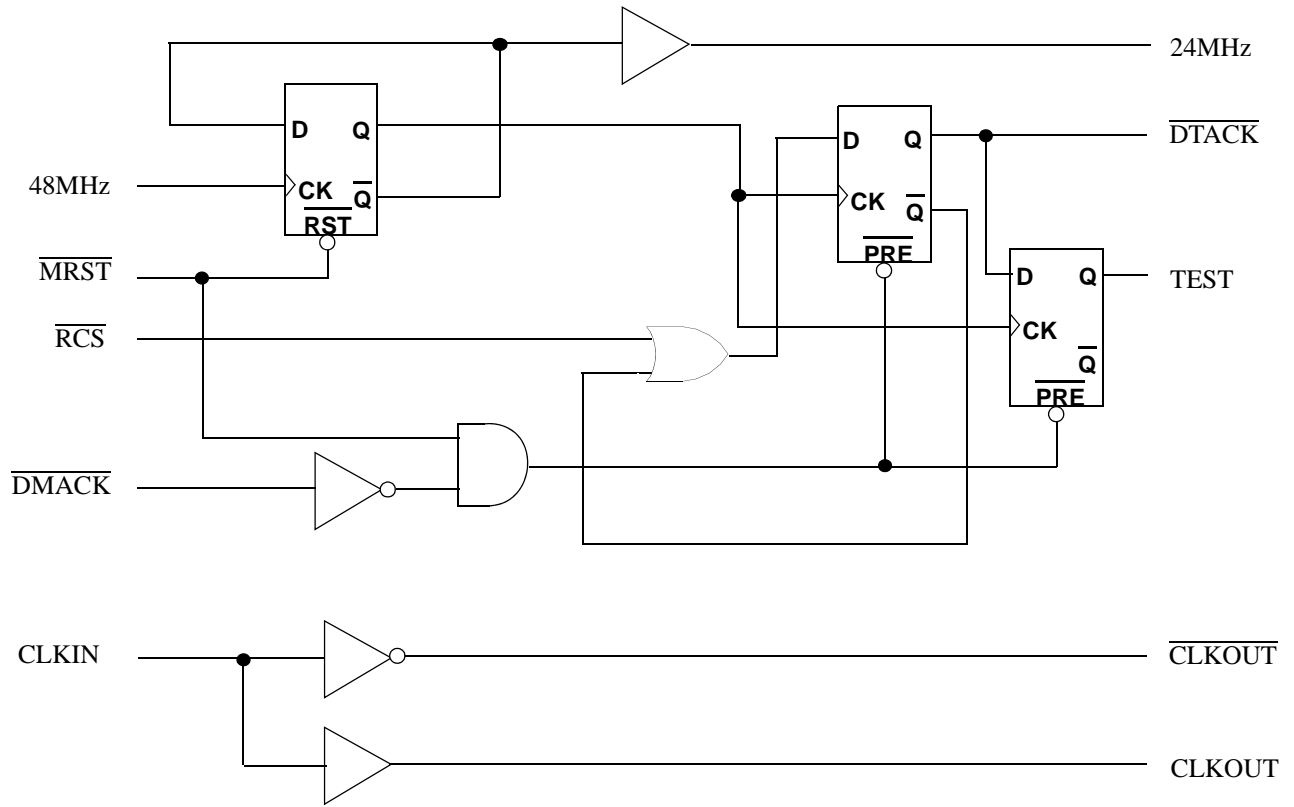

Figure 1. Functional Timing

LOGIC DIAGRAM



RADIATION HARDNESS SPECIFICATIONS ¹

PARAMETER	LIMIT	UNITS
Total Dose	1.0E6	rads(Si)
SEU Threshold ²	80	MeV-cm ² /mg
SEL Threshold	120	MeV-cm ² /mg
Neutron Fluence	1.0E14	n/cm ²

Notes:

- Logic will not latchup during radiation exposure within the limits defined in the table.
- Device storage elements are immune to SEU affects.

ABSOLUTE MAXIMUM RATINGS

SYMBOL	PARAMETER	LIMIT	UNITS
V _{DD}	Supply voltage	-0.3 to 7.0	V
V _{I/O}	Voltage any pin	-.3 to V _{DD} +.3	V
T _{STG}	Storage Temperature range	-65 to +150	°C
T _J	Maximum junction temperature	+175	°C
T _{LS}	Lead temperature (soldering 5 seconds)	+300	°C
Θ _{JC}	Thermal resistance junction to case	20	°C/W
I _I	DC input current	±10	mA
P _D	Maximum power dissipation	1	W

Note:

- Stresses outside the listed absolute maximum ratings may cause permanent damage to the device. This is a stress rating only, functional operation of the device at these or any other conditions beyond limits indicated in the operational sections is not recommended. Exposure to absolute maximum rating conditions for extended periods may affect device reliability.

RECOMMENDED OPERATING CONDITIONS

SYMBOL	PARAMETER	LIMIT	UNITS
V _{DD}	Supply voltage	4.5 to 5.5	V
V _{IN}	Input voltage any pin	0 to V _{DD}	V
T _C	Temperature range	-55 to + 125	°C
48MHz	Duty Cycle	50 ± 20%	MHz

DC ELECTRICAL CHARACTERISTICS ⁷

($V_{DD} = 5.0V \pm 10\%$; $V_{SS} = 0V$ ⁶, $-55^{\circ}C < T_C < +125^{\circ}C$)

SYMBOL	PARAMETER	CONDITION	MIN	MAX	UNIT
V_{IL}	Low-level input voltage ¹ TTL			0.8	V
V_{IH}	High-level input voltage ¹ TTL		.5 V_{DD}		V
I_{IN}	Input leakage current TTL	$V_{IN} = V_{DD}$ or V_{SS}	-1	1	μA
V_{OL1}	Low-level output voltage ³	$I_{OL} = 8mA$ $I_{OL} = 100\mu A$		0.4 0.25	V
V_{OH1}	High-level output voltage ³	$I_{OH} = -8mA$, $V_{DD} = 4.5V$ $I_{OH} = -100\mu A$.7 V_{DD} $V_{DD}-0.25$		V
V_{OL2}	CLKOUT/ \overline{CLKOUT} Low-level output voltage ³	$I_{OL} = 12mA$, $V_{DD} = 4.5V$ $I_{OL} = 100\mu A$		0.4 0.25	V
V_{OH2}	CLKOUT/ \overline{CLKOUT} High-level output voltage ³	$I_{OH} = -12mA$, $V_{DD} = 4.5V$ $I_{OH} = -100\mu A$.7 V_{DD} $V_{DD}-0.25$		V
I_{OS}	Short-circuit output current ^{2,4}	$V_O = V_{DD}$ and V_{SS}	-300	300	mA
I_{OL1}	Output current ¹⁰ (Sink)	$V_{IN} = V_{DD}$ or V_{SS} $V_{OL} = 0.4V$	8		mA
I_{OH1}	Output current ¹⁰ (Source)	$V_{IN} = V_{DD}$ or V_{SS} $V_{OH} = V_{DD} - 0.4V$	-8		mA
I_{OL2}	Output current ¹⁰ (Sink) CLKOUT/ \overline{CLKOUT}	$V_{IN} = V_{DD}$ or V_{SS} $V_{OL} = 0.4V$	12		mA
I_{OH2}	Output current ¹⁰ (Source) CLKOUT/ \overline{CLKOUT}	$V_{IN} = V_{DD}$ or V_{SS} $V_{OH} = V_{DD} - 0.4V$	-12		mA
P_{total}	Power dissipation ^{2, 8, 9}	$C_L = 50pF$		2.0	mW/ MHz
I_{DDQ}	Quiescent Supply Current	$V_{DD} = 5.5V$		10	μA
ΔI_{DDQ}	Quiescent Supply Current Delta	For input under test $V_{IN} = V_{DD} - 2.1V$ For all other inputs $V_{IN} = V_{DD}$ or V_{SS} $V_{DD} = 5.5V$		1.6	mA
C_{IN}	Input capacitance ⁵	$f = 1MHz @ 0V$		15	pF
C_{OUT}	Output capacitance ⁵	$f = 1MHz @ 0V$		15	pF

Notes:

1. Functional tests are conducted in accordance with MIL-STD-883 with the following input test conditions: $V_{IH} = V_{IH(min)} + 20\%$, $- 0\%$; $V_{IL} = V_{IL(max)} + 0\%$, $- 50\%$, as specified herein, for TTL, CMOS, or Schmitt compatible inputs. Devices may be tested using any input voltage within the above specified range, but are guaranteed to $V_{IH(min)}$ and $V_{IL(max)}$.
2. Supplied as a design limit but not guaranteed or tested.
3. Per MIL-PRF-38535, for current density $\leq 5.0E5$ amps/cm², the maximum product of load capacitance (per output buffer) times frequency should not exceed 3,765 pF/MHz.
4. Not more than one output may be shorted at a time for maximum duration of one second.
5. Capacitance measured for initial qualification and when design changes may affect the value. Capacitance is measured between the designated terminal and V_{SS} at frequency of 1MHz and a signal amplitude of 50mV rms maximum.
6. Maximum allowable relative shift equals 50mV.
7. All specifications valid for radiation dose $\leq 1E6$ rads(Si).
8. Power does not include power contribution of any TTL output sink current.
9. Power dissipation specified per switching output.
10. This value is guaranteed based on characterization data, but not tested.

AC ELECTRICAL DIAGRAM

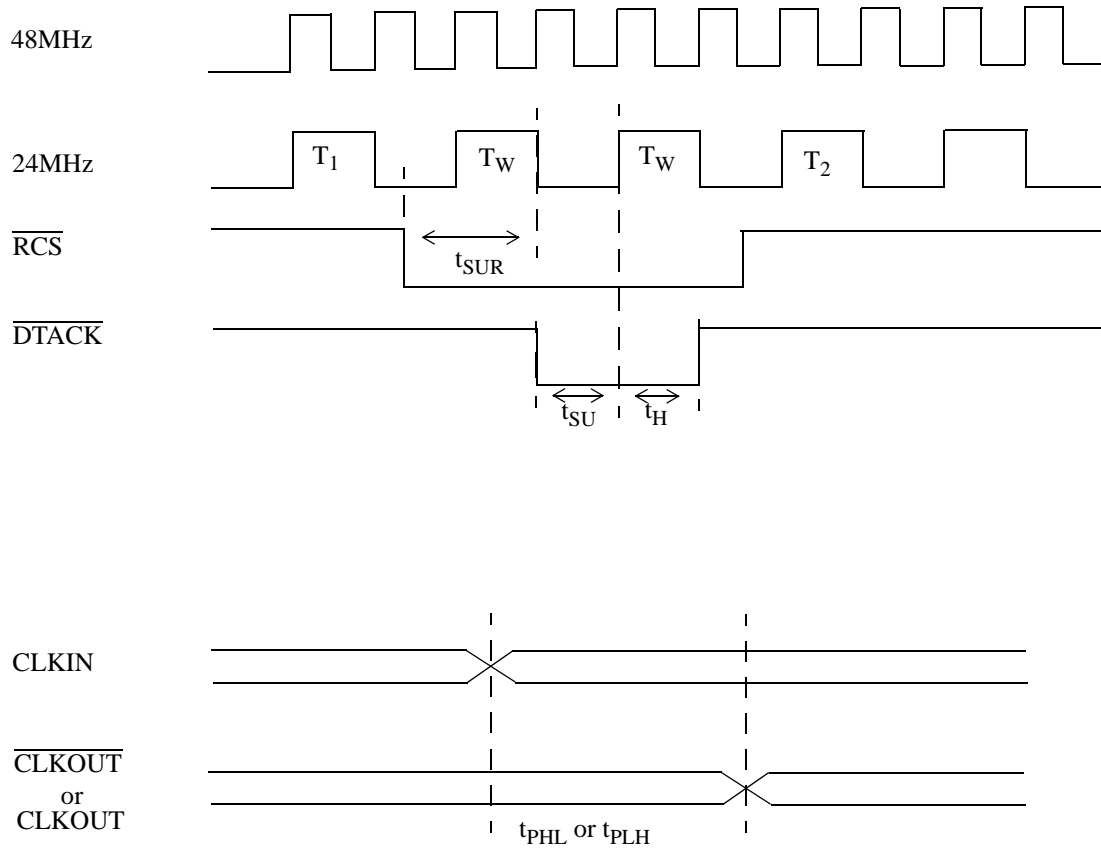

AC ELECTRICAL CHARACTERISTICS ²(V_{DD} = 5.0V ±10%; V_{SS} = 0V 1, -55°C < T_C < +125°C)

SYMBOL	PARAMETER	MINIMUM	MAXIMUM	UNIT
t _{PHL}	48MHz ↑ to 24MHz ↓	0	15	ns
t _{PLH}	48MHz ↑ to 24MHz ↑	0	15	ns
t _{PHL}	24MHz ↓ to $\overline{\text{DTACK}}$ ↓	0	7	ns
t _{PLH}	24MHz ↓ to $\overline{\text{DTACK}}$ ↑	0	6	ns
t _{PLH}	$\overline{\text{DMACK}}$ ↑ to $\overline{\text{DTACK}}$ ↑	3	16	ns
t _{PLH}	$\overline{\text{MRST}}$ ↓ to 24MHz, $\overline{\text{DTACK}}$ ↑	3	16	ns
t _{PHL}	CLKIN ↓ to CLKOUT ↓	0	11	ns
t _{PLH}	CLKIN ↑ to CLKOUT ↑	0	11	ns
t _{PHL}	CLKIN ↑ to $\overline{\text{CLKOUT}}$ ↓	0	11	ns
t _{PLH}	CLKIN ↓ to $\overline{\text{CLKOUT}}$ ↑	0	11	ns
t _{SU} ³	$\overline{\text{DTACK}}$ ↓ to 24MHz ↑	12		ns
t _H ³	24MHz ↑ to $\overline{\text{DTACK}}$ ↑	20		ns
t _{SUR}	Setup time from $\overline{\text{RCS}}$ ↓ to 24MHz ↓	16		ns
t _{WM}	$\overline{\text{MRST}}$ pulse width	5		ns
t _{WC}	CLKIN pulse width	12		ns
f _{MAX}	CLKIN		40	MHz

Notes:

1. Maximum allowable relative shift equals 50mV.
2. All specifications valid for radiation dose ≤ 1E6 rads(Si).
3. Guaranteed by design but not tested.

UT54ACS240/UT54ACTS240

Radiation-Hardened

Octal Buffers & Line Drivers, Inverted Three-State Outputs

FEATURES

- Three-state outputs drive bus lines or buffer memory address registers
- 1.2μ radiation-hardened CMOS
 - Latchup immune
- High speed
- Low power consumption
- Single 5 volt supply
- Available QML Q or V processes
- Flexible package
 - 20-pin DIP
 - 20-lead flatpack

DESCRIPTION

The UT54ACS240 and the UT54ACTS240 are inverting octal buffer and line drivers which improve the performance and density of three-state memory address drivers, clock drivers, and bus-oriented receivers and transmitters.

The devices are characterized over full military temperature range of -55°C to +125°C.

FUNCTION TABLE

INPUTS		OUTPUT
$\overline{1G}, 2G$	A	Y
L	L	H
L	H	L
H	X	Z

LOGIC SYMBOL

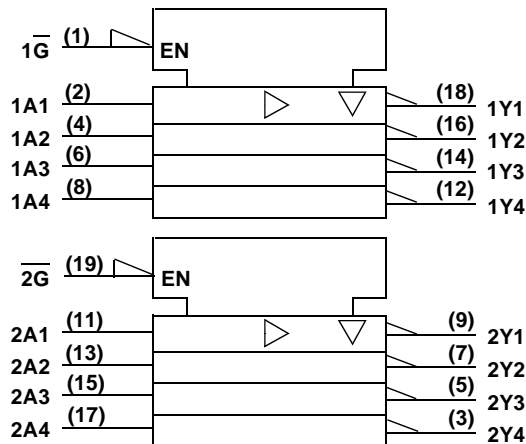

Note:

1. Logic symbol in accordance with ANSI/IEEE Std 91-1984 and IEC Publication 617-12.

PINOUTS

20-Pin DIP Top View

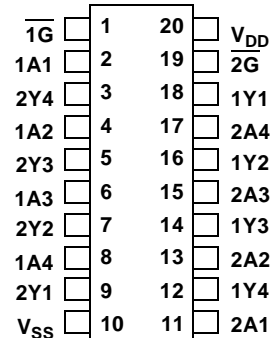

20-Lead Flatpack Top View

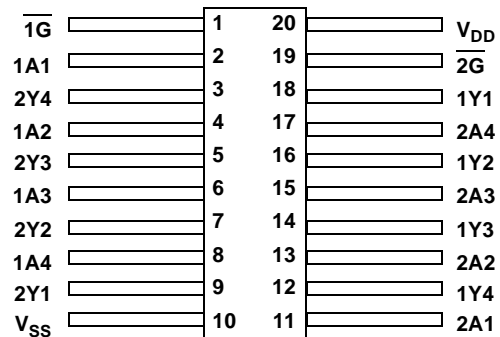

LOGIC DIAGRAM

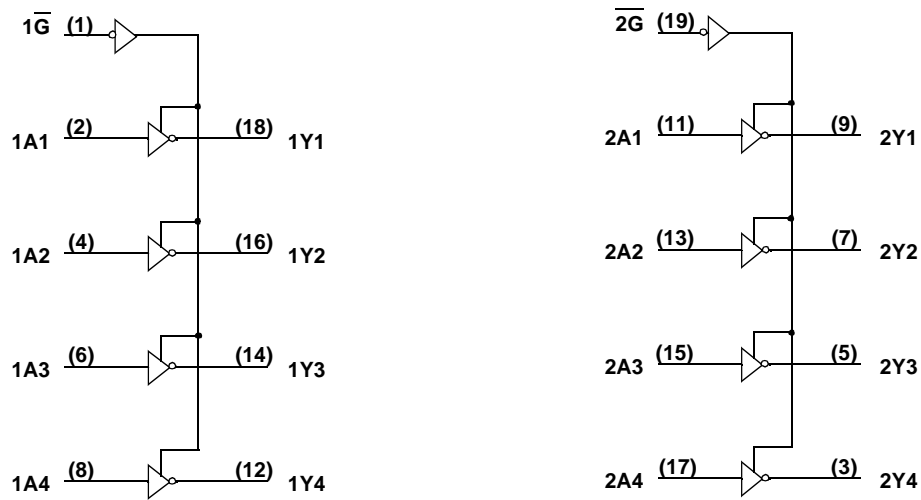

RADIATION HARDNESS SPECIFICATIONS ¹

PARAMETER	LIMIT	UNITS
Total Dose	1.0E6	rads(Si)
SEU Threshold ²	80	MeV-cm ² /mg
SEL Threshold	120	MeV-cm ² /mg
Neutron Fluence	1.0E14	n/cm ²

Notes:

1. Logic will not latchup during radiation exposure within the limits defined in the table
2. Device storage elements are immune to SEU affects.

ABSOLUTE MAXIMUM RATINGS

SYMBOL	PARAMETER	LIMIT	UNITS
V _{DD}	Supply voltage	-0.3 to 7.0	V
V _{I/O}	Voltage any pin	-.3 to V _{DD} +.3	V
T _{STG}	Storage Temperature range	-65 to +150	°C
T _J	Maximum junction temperature	+175	°C
T _{LS}	Lead temperature (soldering 5 seconds)	+300	°C
Θ _{JC}	Thermal resistance junction to case	20	°C/W
I _I	DC input current	±10	mA
P _D	Maximum power dissipation	1	W

Note:

1. Stresses outside the listed absolute maximum ratings may cause permanent damage to the device. This is a stress rating only, functional operation of the device at these or any other conditions beyond limits indicated in the operational sections is not recommended. Exposure to absolute maximum rating conditions for extended periods may affect device reliability.

RECOMMENDED OPERATING CONDITIONS

SYMBOL	PARAMETER	LIMIT	UNITS
V_{DD}	Supply voltage	4.5 to 5.5	V
V_{IN}	Input voltage any pin	0 to V_{DD}	V
T_C	Temperature range	-55 to + 125	°C

DC ELECTRICAL CHARACTERISTICS ⁷(V_{DD} = 5.0V ±10%; V_{SS} = 0V ⁶, -55 °C < T_C < +125°C)

SYMBOL	PARAMETER	CONDITION	MIN	MAX	UNIT
V _{IL}	Low-level input voltage ¹ ACTS ACS			0.8 .3V _{DD}	V
V _{IH}	High-level input voltage ¹ ACTS ACS		.5V _{DD} .7V _{DD}		V
I _{IN}	Input leakage current ACTS/ACS	V _{IN} = V _{DD} or V _{SS}	-1	1	μA
V _{OL}	Low-level output voltage ³ ACTS ACS	I _{OL} = 12.0mA I _{OL} = 100μA		0.40 0.25	V
V _{OH}	High-level output voltage ³ ACTS ACS	I _{OH} = -12.0mA I _{OH} = -100μA	.7V _{DD} V _{DD} - 0.25		V
I _{OZ}	Three-state output leakage current	V _O = V _{DD} and V _{SS}	-30	30	μA
I _{OS}	Short-circuit output current ^{2,4} ACTS/ACS	V _O = V _{DD} and V _{SS}	-300	300	mA
I _{OL}	Output current ¹⁰ (Sink)	V _{IN} = V _{DD} or V _{SS} V _{OL} = 0.4V	12		mA
I _{OH}	Output current ¹⁰ (Source)	V _{IN} = V _{DD} or V _{SS} V _{OH} = V _{DD} - 0.4V	-12		mA
P _{total}	Power dissipation ^{2, 8, 9}	C _L = 50pF		2.1	mW/ MHz
I _{DDQ}	Quiescent Supply Current	V _{DD} = 5.5V		10	μA
ΔI _{DDQ}	Quiescent Supply Current Delta ACTS	For input under test V _{IN} = V _{DD} - 2.1V For all other inputs V _{IN} = V _{DD} or V _{SS} V _{DD} = 5.5V		1.6	mA
C _{IN}	Input capacitance ⁵	f = 1MHz @ 0V		15	pF
C _{OUT}	Output capacitance ⁵	f = 1MHz @ 0V		15	pF

UT54ACS240/UT54ACTS240

Notes:

1. Functional tests are conducted in accordance with MIL-STD-883 with the following input test conditions: $V_{IH} = V_{IH(min)} + 20\%$, $- 0\%$; $V_{IL} = V_{IL(max)} + 0\%$, $- 50\%$, as specified herein, for TTL, CMOS, or Schmitt compatible inputs. Devices may be tested using any input voltage within the above specified range, but are guaranteed to $V_{IH(min)}$ and $V_{IL(max)}$.
2. Supplied as a design limit but not guaranteed or tested.
3. Per MIL-PRF-38535, for current density $\leq 5.0E5$ amps/cm², the maximum product of load capacitance (per output buffer) times frequency should not exceed 3,765 pF/MHz.
4. Not more than one output may be shorted at a time for maximum duration of one second.
5. Capacitance measured for initial qualification and when design changes may affect the value. Capacitance is measured between the designated terminal and V_{SS} at frequency of 1MHz and a signal amplitude of 50mV rms maximum.
6. Maximum allowable relative shift equals 50mV.
7. All specifications valid for radiation dose $\leq 1E6$ rads(Si).
8. Power does not include power contribution of any TTL output sink current.
9. Power dissipation specified per switching output.
10. This value is guaranteed based on characterization data, but not tested.

AC ELECTRICAL CHARACTERISTICS ²(V_{DD} = 5.0V ±10%; V_{SS} = 0V ¹, -55 °C < T_C < +125°C)

SYMBOL	PARAMETER	MINIMUM	MAXIMUM	UNIT
t _{PLH}	Input to Yn	1	10	ns
t _{PHL}	Input to Yn	1	13	ns
t _{PZL}	\overline{G} low to Yn active	1	11	ns
t _{PZH}	\overline{G} low to Yn active	2	13	ns
t _{PLZ}	\overline{G} high to Yn three-state	2	11	ns
t _{PHZ}	\overline{G} high to Yn three-state	2	14	ns

Notes:

1. Maximum allowable relative shift equals 50mV.
2. All specifications valid for radiation dose ≤ 1E6 rads(Si).

UT54ACS244/UT54ACTS244

Radiation-Hardened Octal Buffers & Line Drivers, Three-State Outputs

FEATURES

- Three-state outputs drive bus lines or buffer memory address registers
- 1.2μ radiation-hardened CMOS
 - Latchup immune
- High speed
- Low power consumption
- Single 5 volt supply
- Available QML Q or V processes
- Flexible package
 - 20-pin DIP
 - 20-lead flatpack

DESCRIPTION

The UT54ACS244 and the UT54ACTS244 are non-inverting octal buffer and line drivers which improve the performance and density of three-state memory address drivers, clock drivers, and bus-oriented receivers and transmitters.

The devices are characterized over full military temperature range of -55°C to +125°C.

FUNCTION TABLE

INPUTS		OUTPUT
$\overline{1G}, 2G$	A	Y
L	L	L
L	H	H
H	X	Z

LOGIC SYMBOL

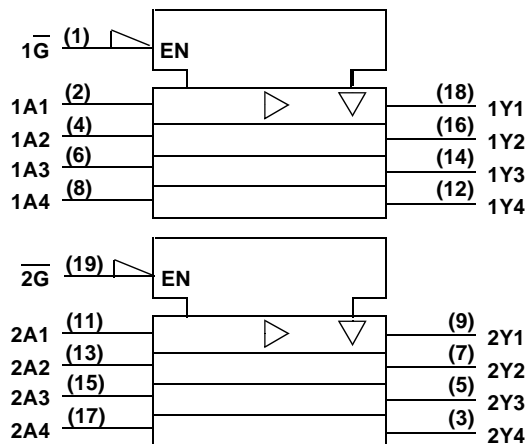

Note:

1. Logic symbol in accordance with ANSI/IEEE Std 91-1984 and IEC Publication 617-12.

PINOUTS

20-Pin DIP Top View

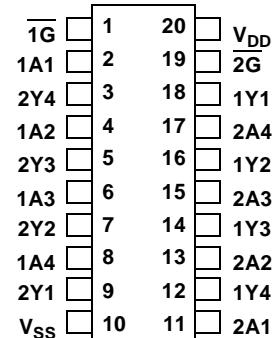

20-Lead Flatpack Top View

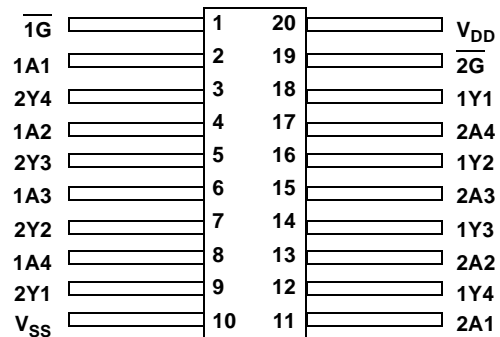

LOGIC DIAGRAM

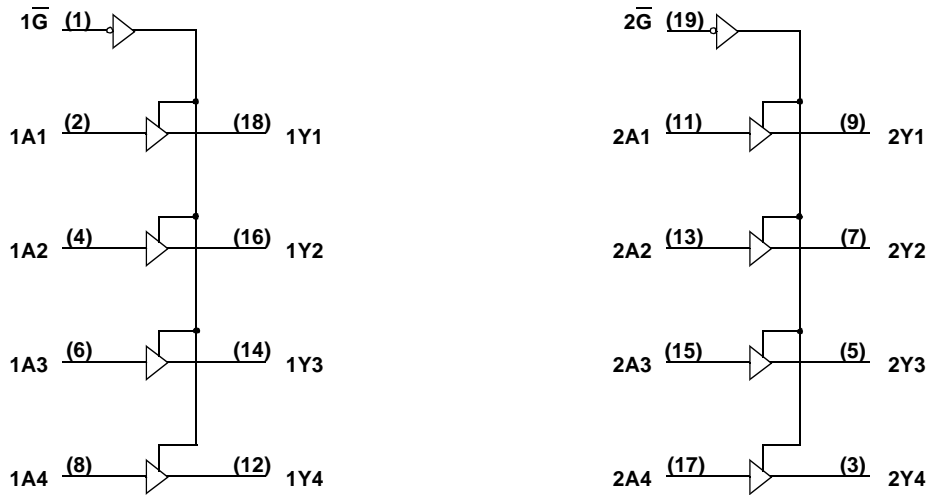

RADIATION HARDNESS SPECIFICATIONS ¹

PARAMETER	LIMIT	UNITS
Total Dose	1.0E6	rads(Si)
SEU Threshold ²	80	MeV-cm ² /mg
SEL Threshold	120	MeV-cm ² /mg
Neutron Fluence	1.0E14	n/cm ²

Notes:

1. Logic will not latchup during radiation exposure within the limits defined in the table
2. Device storage elements are immune to SEU affects.

ABSOLUTE MAXIMUM RATINGS

SYMBOL	PARAMETER	LIMIT	UNITS
V _{DD}	Supply voltage	-0.3 to 7.0	V
V _{I/O}	Voltage any pin	-.3 to V _{DD} +.3	V
T _{STG}	Storage Temperature range	-65 to +150	°C
T _J	Maximum junction temperature	+175	°C
T _{LS}	Lead temperature (soldering 5 seconds)	+300	°C
Θ _{JC}	Thermal resistance junction to case	20	°C/W
I _I	DC input current	±10	mA
P _D	Maximum power dissipation	1	W

Note:

1. Stresses outside the listed absolute maximum ratings may cause permanent damage to the device. This is a stress rating only, functional operation of the device at these or any other conditions beyond limits indicated in the operational sections is not recommended. Exposure to absolute maximum rating conditions for extended periods may affect device reliability.

RECOMMENDED OPERATING CONDITIONS

SYMBOL	PARAMETER	LIMIT	UNITS
V_{DD}	Supply voltage	4.5 to 5.5	V
V_{IN}	Input voltage any pin	0 to V_{DD}	V
T_C	Temperature range	-55 to + 125	°C

DC ELECTRICAL CHARACTERISTICS ⁷(V_{DD} = 5.0V ±10%; V_{SS} = 0V ⁶, -55 °C < T_C < +125°C)

SYMBOL	PARAMETER	CONDITION	MIN	MAX	UNIT
V _{IL}	Low-level input voltage ¹ ACTS ACS			0.8 .3V _{DD}	V
V _{IH}	High-level input voltage ¹ ACTS ACS		.5V _{DD} .7V _{DD}		V
I _{IN}	Input leakage current ACTS/ACS	V _{IN} = V _{DD} or V _{SS}	-1	1	μA
V _{OL}	Low-level output voltage ³ ACTS ACS	I _{OL} = 12.0mA I _{OL} = 100μA		0.40 0.25	V
V _{OH}	High-level output voltage ³ ACTS ACS	I _{OH} = -12.0mA I _{OH} = -100μA	.7V _{DD} V _{DD} - 0.25		V
I _{OL}	Output current ¹⁰ (Sink)	V _{IN} = V _{DD} or V _{SS} V _{OL} = 0.4V	12		mA
I _{OH}	Output current ¹⁰ (Source)	V _{IN} = V _{DD} or V _{SS} V _{OH} = V _{DD} - 0.4V	-12		mA
I _{OZ}	Three-state output leakage current	V _O = V _{DD} and V _{SS}	-30	30	μA
I _{OS}	Short-circuit output current ^{2,4} ACTS/ACS	V _O = V _{DD} and V _{SS}	-300	300	mA
P _{total}	Power dissipation ^{2,8,9}	C _L = 50pF		2.0	mW/ MHz
I _{DDQ}	Quiescent Supply Current	V _{DD} = 5.5V		10	μA
ΔI _{DDQ}	Quiescent Supply Current Delta ACTS	For input under test V _{IN} = V _{DD} - 2.1V For all other inputs V _{IN} = V _{DD} or V _{SS} V _{DD} = 5.5V		1.6	mA
C _{IN}	Input capacitance ⁵	f = 1MHz @ 0V		15	pF
C _{OUT}	Output capacitance ⁵	f = 1MHz @ 0V		15	pF

UT54ACS244/UT54ACTS244

Notes:

1. Functional tests are conducted in accordance with MIL-STD-883 with the following input test conditions: $V_{IH} = V_{IH(min)} + 20\%$, $- 0\%$; $V_{IL} = V_{IL(max)} + 0\%$, $- 50\%$, as specified herein, for TTL, CMOS, or Schmitt compatible inputs. Devices may be tested using any input voltage within the above specified range, but are guaranteed to $V_{IH(min)}$ and $V_{IL(max)}$.
2. Supplied as a design limit but not guaranteed or tested.
3. Per MIL-PRF-38535, for current density $\leq 5.0E5$ amps/cm², the maximum product of load capacitance (per output buffer) times frequency should not exceed 3,765 pF/MHz.
4. Not more than one output may be shorted at a time for maximum duration of one second.
5. Capacitance measured for initial qualification and when design changes may affect the value. Capacitance is measured between the designated terminal and V_{SS} at frequency of 1MHz and a signal amplitude of 50mV rms maximum.
6. Maximum allowable relative shift equals 50mV.
7. All specifications valid for radiation dose $\leq 1E6$ rads(Si).
8. Power does not include power contribution of any TTL output sink current.
9. Power dissipation specified per switching output.
10. This value is guaranteed based on characterization data, but not tested.

AC ELECTRICAL CHARACTERISTICS ²(V_{DD} = 5.0V ±10%; V_{SS} = 0V ¹, -55 °C < T_C < +125°C)

SYMBOL	PARAMETER	MINIMUM	MAXIMUM	UNIT
t _{PLH}	Input to Yn	1	11	ns
t _{PHL}	Input to Yn	1	11	ns
t _{PZL}	\overline{G} low to Yn active	2	12	ns
t _{PZH}	\overline{G} low to Yn active	2	12	ns
t _{PLZ}	\overline{G} high to Yn three-state	2	12	ns
t _{PHZ}	\overline{G} high to Yn three-state	2	12	ns

Notes:

1. Maximum allowable relative shift equals 50mV.
2. All specifications valid for radiation dose ≤ 1E6 rads(Si).

UT54ACS245/UT54ACTS245

Radiation-Hardened Octal Bus Transceiver with Three-State Outputs

FEATURES

- Three-state outputs drive bus line directly
- 1.2μ radiation-hardened CMOS
 - Latchup immune
- High speed
- Low power consumption
- Single 5 volt supply
- Available QML Q or V processes
- Flexible package
 - 20-pin DIP
 - 20-lead flatpack

DESCRIPTION

The UT54ACS245 and the UT54ACTS245 are non-inverting octal bus transceivers designed for asynchronous two-way communication between data buses. The control function implementation minimizes external timing requirements.

The devices allow data transmission from the A bus to the B bus or from the B bus to the A bus depending upon the logic level at the direction control (DIR) input. The enable input (\overline{G}) disables the device so that the buses are effectively isolated.

The devices are characterized over full military temperature range of -55°C to $+125^{\circ}\text{C}$.

FUNCTION TABLE

ENABLE \overline{G}	DIRECTION CONTROL DIR	OPERATION
L	L	B Data To A Bus
L	H	A Data To B Bus
H	X	Isolation

PINOUTS

20-Pin DIP
Top View

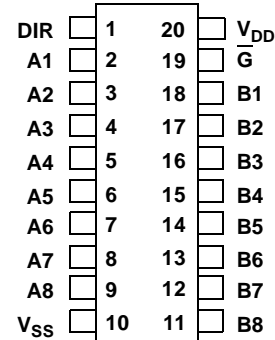

20-Lead Flatpack
Top View

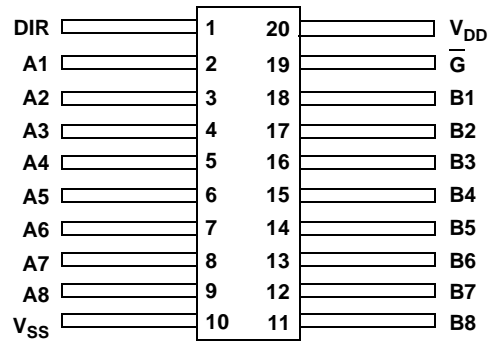

LOGIC SYMBOL

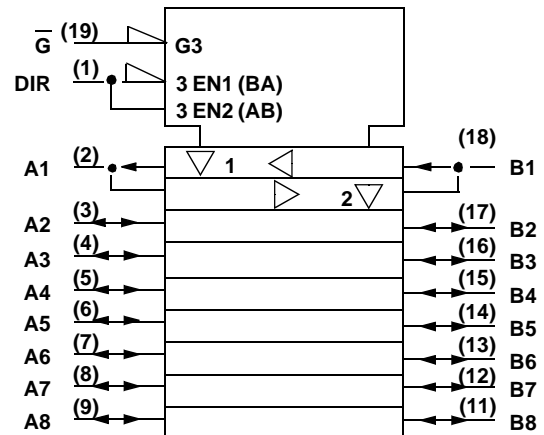

Note:

1. Logic symbol in accordance with ANSI/IEEE Std 91-1984 and IEC Publication 617-12.

LOGIC DIAGRAM

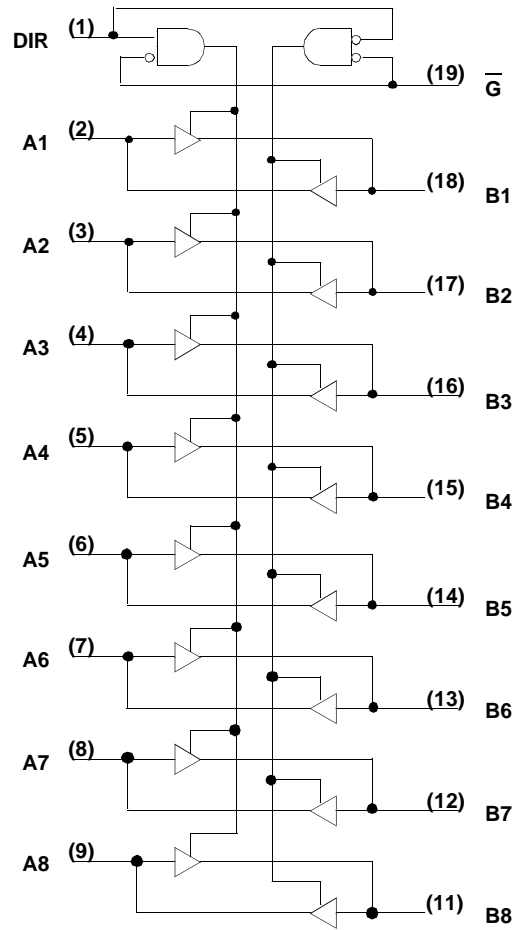

RADIATION HARDNESS SPECIFICATIONS ¹

PARAMETER	LIMIT	UNITS
Total Dose	1.0E6	rads(Si)
SEU Threshold ²	80	MeV-cm ² /mg
SEL Threshold	120	MeV-cm ² /mg
Neutron Fluence	1.0E14	n/cm ²

Notes:

1. Logic will not latchup during radiation exposure within the limits defined in the table.
2. Device storage elements are immune to SEU affects.

ABSOLUTE MAXIMUM RATINGS

SYMBOL	PARAMETER	LIMIT	UNITS
V _{DD}	Supply voltage	-0.3 to 7.0	V
V _{I/O}	Voltage any pin	-.3 to V _{DD} +.3	V
T _{STG}	Storage Temperature range	-65 to +150	°C
T _J	Maximum junction temperature	+175	°C
T _{LS}	Lead temperature (soldering 5 seconds)	+300	°C
Θ _{JC}	Thermal resistance junction to case	20	°C/W
I _I	DC input current	±10	mA
P _D	Maximum power dissipation	1	W

Note:

1. Stresses outside the listed absolute maximum ratings may cause permanent damage to the device. This is a stress rating only, functional operation of the device at these or any other conditions beyond limits indicated in the operational sections is not recommended. Exposure to absolute maximum rating conditions for extended periods may affect device reliability.

RECOMMENDED OPERATING CONDITIONS

SYMBOL	PARAMETER	LIMIT	UNITS
V _{DD}	Supply voltage	4.5 to 5.5	V
V _{IN}	Input voltage any pin	0 to V _{DD}	V
T _C	Temperature range	-55 to + 125	°C

DC ELECTRICAL CHARACTERISTICS ⁷(V_{DD} = 5.0V ±10%; V_{SS} = 0V ⁶, -55 °C < T_C < +125°C)

SYMBOL	PARAMETER	CONDITION	MIN	MAX	UNIT
V _{IL}	Low-level input voltage ¹ ACTS ACS			0.8 .3V _{DD}	V
V _{IH}	High-level input voltage ¹ ACTS ACS		.5V _{DD} .7V _{DD}		V
I _{IN}	Input leakage current ACTS/ACS	V _{IN} = V _{DD} or V _{SS}	-1	1	μA
V _{OL}	Low-level output voltage ³ ACTS ACS	I _{OL} = 12.0mA I _{OL} = 100μA		0.40 0.25	V
V _{OH}	High-level output voltage ³ ACTS ACS	I _{OH} = -12.0mA I _{OH} = -100μA	.7V _{DD} V _{DD} - 0.25		V
I _{OZ}	Three-state output leakage current	V _O = V _{DD} and V _{SS}	-30	30	μA
I _{OS}	Short-circuit output current ^{2,4} ACTS/ACS	V _O = V _{DD} and V _{SS}	-300	300	mA
I _{OL}	Output current ¹⁰ (Sink)	V _{IN} = V _{DD} or V _{SS} V _{OL} = 0.4V	12		mA
I _{OH}	Output current ¹⁰ (Source)	V _{IN} = V _{DD} or V _{SS} V _{OH} = V _{DD} - 0.4V	-12		mA
P _{total}	Power dissipation ^{2, 8, 9}	C _L = 50pF		2.0	mW/MHz
I _{DDQ}	Quiescent Supply Current	V _{DD} = 5.5V		10	μA
ΔI _{DDQ}	Quiescent Supply Current Delta ACTS	For input under test V _{IN} = V _{DD} - 2.1V For all other inputs V _{IN} = V _{DD} or V _{SS} V _{DD} = 5.5V		1.6	mA
C _{IN}	Input capacitance ⁵	f = 1MHz @ 0V		15	pF
C _{OUT}	Output capacitance ⁵	f = 1MHz @ 0V		15	pF

UT54ACS245/UT54ACTS245

Notes:

1. Functional tests are conducted in accordance with MIL-STD-883 with the following input test conditions: $V_{IH} = V_{IH(min)} + 20\%$, $- 0\%$; $V_{IL} = V_{IL(max)} + 0\%$, $- 50\%$, as specified herein, for TTL, CMOS, or Schmitt compatible inputs. Devices may be tested using any input voltage within the above specified range, but are guaranteed to $V_{IH(min)}$ and $V_{IL(max)}$.
2. Supplied as a design limit but not guaranteed or tested.
3. Per MIL-PRF-38535, for current density $\leq 5.0E5$ amps/cm², the maximum product of load capacitance (per output buffer) times frequency should not exceed 3,765 pF/MHz.
4. Not more than one output may be shorted at a time for maximum duration of one second.
5. Capacitance measured for initial qualification and when design changes may affect the value. Capacitance is measured between the designated terminal and V_{SS} at frequency of 1MHz and a signal amplitude of 50mV rms maximum.
6. Maximum allowable relative shift equals 50mV.
7. All specifications valid for radiation dose $\leq 1E6$ rads(Si).
8. Power does not include power contribution of any TTL output sink current.
9. Power dissipation specified per switching output.
10. This value is guaranteed based on characterization data, but not tested.

AC ELECTRICAL CHARACTERISTICS ²(V_{DD} = 5.0V ±10%; V_{SS} = 0V ¹, -55 °C < T_C < +125°C)

SYMBOL	PARAMETER	MINIMUM	MAXIMUM	UNIT
t _{PLH}	Data to bus	1	11	ns
t _{PHL}	Data to bus	1	15	ns
t _{PZL}	\overline{G} low to bus active	2	12	ns
t _{PZH}	\overline{G} low to bus active	2	12	ns
t _{PLZ}	\overline{G} high to bus three-state	2	12	ns
t _{PHZ}	\overline{G} high to bus three-state	2	12	ns

Notes:

1. Maximum allowable relative shift equals 50mV.
2. All specifications valid for radiation dose ≤ 1E6 rads(Si)

UT54ACS253/UT54ACTS253

Radiation-Hardened Dual 4-Input Multiplexers, Three-State Outputs

FEATURES

- Permits multiplexing from N lines to 1 line
- Performs parallel-to-serial conversion
- 1.2μ radiation-hardened CMOS
 - Latchup immune
- High speed
- Low power consumption
- Single 5 volt supply
- Available QML Q or V processes
- Flexible package
 - 16-pin DIP
 - 16-lead flatpack

DESCRIPTION

The UT54ACS253 and the UT54ACTS253 are 1-line to 4-line multiplexers that contain drivers to supply full binary decoding. Separate output control inputs are provided for each of the two four-line sections.

Use the three-state outputs to drive data lines in bus-organized systems. With all but one of the common outputs disabled the low-impedance of the single enable output will drive the bus line to a high or low logic level. Each output has its own strobe (\overline{G}).

The devices are characterized over full military temperature range of -55°C to +125°C.

FUNCTION TABLE

SELECT INPUTS		DATA INPUTS				OUTPUT CONTROL	OUTPUT
B	A	C0	C1	C2	C3	\overline{G}	Y
X	X	X	X	X	X	H	Z
L	L	L	X	X	X	L	L
L	L	H	X	X	X	L	H
L	H	X	L	X	X	L	L
L	H	X	H	X	X	L	H
H	L	X	X	L	X	L	L
H	L	X	X	H	X	L	H
H	H	X	X	X	L	L	L
H	H	X	X	X	H	L	H

PINOUTS

16-Pin DIP Top View

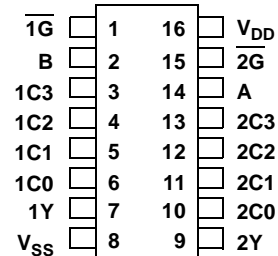

16-Lead Flatpack Top View

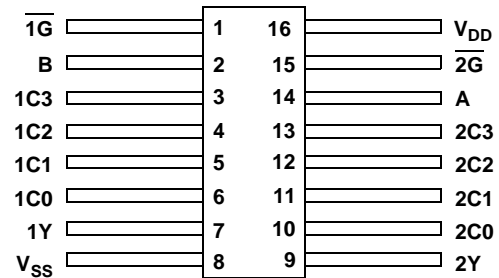

LOGIC SYMBOL

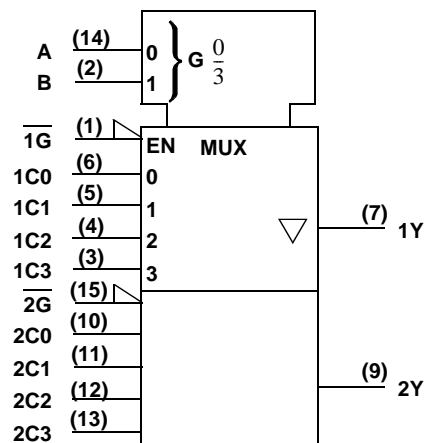

Note:

1. Logic symbol in accordance with ANSI/IEEE Std 91-1984 and IEC Publication 617-12.

LOGIC DIAGRAM

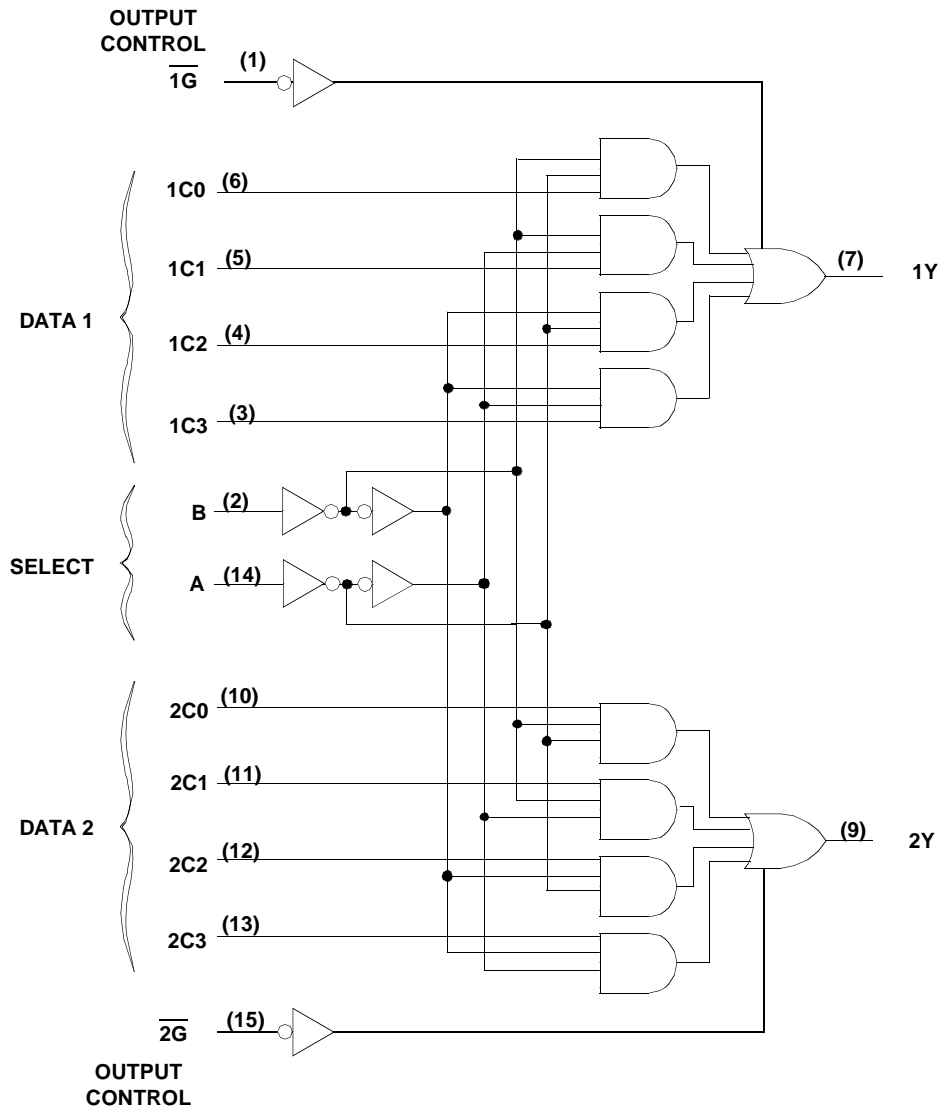

RADIATION HARDNESS SPECIFICATIONS ¹

PARAMETER	LIMIT	UNITS
Total Dose	1.0E6	rads(Si)
SEU Threshold ²	80	MeV-cm ² /mg
SEL Threshold	120	MeV-cm ² /mg
Neutron Fluence	1.0E14	n/cm ²

Notes:

1. Logic will not latchup during radiation exposure within the limits defined in the table.
2. Device storage elements are immune to SEU affects.

ABSOLUTE MAXIMUM RATINGS

SYMBOL	PARAMETER	LIMIT	UNITS
V _{DD}	Supply voltage	-0.3 to 7.0	V
V _{I/O}	Voltage any pin	-.3 to V _{DD} +.3	V
T _{STG}	Storage Temperature range	-65 to +150	°C
T _J	Maximum junction temperature	+175	°C
T _{LS}	Lead temperature (soldering 5 seconds)	+300	°C
Θ _{JC}	Thermal resistance junction to case	20	°C/W
I _I	DC input current	±10	mA
P _D	Maximum power dissipation	1	W

Note:

1. Stresses outside the listed absolute maximum ratings may cause permanent damage to the device. This is a stress rating only, functional operation of the device at these or any other conditions beyond limits indicated in the operational sections is not recommended. Exposure to absolute maximum rating conditions for extended periods may affect device reliability.

RECOMMENDED OPERATING CONDITIONS

SYMBOL	PARAMETER	LIMIT	UNITS
V _{DD}	Supply voltage	4.5 to 5.5	V
V _{IN}	Input voltage any pin	0 to V _{DD}	V
T _C	Temperature range	-55 to + 125	°C

DC ELECTRICAL CHARACTERISTICS ⁷(V_{DD} = 5.0V ±10%; V_{SS} = 0V ⁶, -55°C < T_C < +125 °C)

SYMBOL	PARAMETER	CONDITION	MIN	MAX	UNIT
V _{IL}	Low-level input voltage ¹ ACTS ACS			0.8 .3V _{DD}	V
V _{IH}	High-level input voltage ¹ ACTS ACS		.5V _{DD} .7V _{DD}		V
I _{IN}	Input leakage current ACTS/ACS	V _{IN} = V _{DD} or V _{SS}	-1	1	μA
V _{OL}	Low-level output voltage ³ ACTS ACS	I _{OL} = 8.0mA I _{OL} = 100μA		0.40 0.25	V
V _{OH}	High-level output voltage ³ ACTS ACS	I _{OH} = -8.0mA I _{OH} = -100μA	.7V _{DD} V _{DD} - 0.25		V
I _{OS}	Short-circuit output current ^{2,4} ACTS/ACS	V _O = V _{DD} and V _{SS}	-200	200	mA
I _{OZ}	Three-state output leakage current	V _O = V _{DD} and V _{SS}	-20	20	μA
I _{DDQ}	Quiescent Supply Current	V _{DD} = 5.5V		10	μA
I _{OL}	Output current ¹⁰ (Sink)	V _{IN} = V _{DD} or V _{SS} V _{OL} = 0.4V	8		mA
I _{OH}	Output current ¹⁰ (Source)	V _{IN} = V _{DD} or V _{SS} V _{OH} = V _{DD} - 0.4V	-8		mA
P _{total}	Power dissipation ^{2, 8, 9}	C _L = 50pF		2.1	mW/ MHz
I _{DDQ}	Quiescent Supply Current	V _{DD} = 5.5V		10	μA
ΔI _{DDQ}	Quiescent Supply Current Delta ACTS	For input under test V _{IN} = V _{DD} - 2.1V For all other inputs V _{IN} = V _{DD} or V _{SS} V _{DD} = 5.5V		1.6	mA
C _{IN}	Input capacitance ⁵	f = 1MHz @ 0V		15	pF
C _{OUT}	Output capacitance ⁵	f = 1MHz @ 0V		15	pF

Notes:

1. Functional tests are conducted in accordance with MIL-STD-883 with the following input test conditions: $V_{IH} = V_{IH(min)} + 20\%$, $- 0\%$; $V_{IL} = V_{IL(max)} + 0\%$, $- 50\%$, as specified herein, for TTL, CMOS, or Schmitt compatible inputs. Devices may be tested using any input voltage within the above specified range, but are guaranteed to $V_{IH(min)}$ and $V_{IL(max)}$.
2. Supplied as a design limit but not guaranteed or tested.
3. Per MIL-PRF-38535, for current density $\leq 5.0E5$ amps/cm², the maximum product of load capacitance (per output buffer) times frequency should not exceed 3,765 pF/MHz.
4. Not more than one output may be shorted at a time for maximum duration of one second.
5. Capacitance measured for initial qualification and when design changes may affect the value. Capacitance is measured between the designated terminal and V_{SS} at frequency of 1MHz and a signal amplitude of 50mV rms maximum.
6. Maximum allowable relative shift equals 50mV.
7. All specifications valid for radiation dose $\leq 1E6$ rads(Si).
8. Power does not include power contribution of any TTL output sink current.
9. Power dissipation specified per switching output.
10. This value is guaranteed based on characterization data, but not tested.

AC ELECTRICAL CHARACTERISTICS ²(V_{DD} = 5.0V ±10%; V_{SS} = 0V ¹, -55°C < T_C < +125 °C)

SYMBOL	PARAMETER	MINIMUM	MAXIMUM	UNIT
t _{PLH}	Select to output Yn	2	12	ns
t _{PHL}	Select to output Yn	2	16	ns
t _{PLH}	Data to output Yn	2	14	ns
t _{PHL}	Data to output Yn	2	16	ns
t _{PZH}	\overline{G} low to Yn active	2	12	ns
t _{PZL}	\overline{G} low to Yn active	1	12	ns
t _{PHZ}	\overline{G} high to Yn three-state	2	11	ns
t _{PLZ}	\overline{G} high to Yn three-state	2	10	ns

Notes:

1. Maximum allowable relative shift equals 50mV.
2. All specifications valid for radiation dose ≤ 1E6 rads(Si).

UT54ACS264/UT54ACTS264

Radiation-Hardened Look-Ahead Carry Generators for Counters

FEATURES

- Performs look-ahead carry across n-bit counters
- Accommodates active-high or active-low carry
- Improves cascaded counters system performance
- 1.2 μ radiation-hardened CMOS
 - Latchup immune
- High speed
- Low power consumption
- Single 5 volt supply
- Available QML Q or V processes
- Flexible package
 - 16-pin DIP
 - 16-lead flatpack

DESCRIPTION

The UT54ACS264 and the UT54ACTS264 are look-ahead generators designed specifically to perform a carry-anticipate across any number of n-bit counters, thus increasing system clock frequency. A carry enable CE, and carry outputs RCOA and RCOB are provided for n-bit cascading.

Use the counter with either active-high-carry or active-low-carry counters. For active-high-carry counters, CE is active high, the A set of inputs and output RCOA are used. The B set of inputs are connected to a low logic level. For active-low-carry counters, CE is active low, the B set of inputs and output RCOB are used. The A set of inputs are connected to a high logic level.

The devices are characterized over full military temperature range of -55°C to +125°C.

PINOUTS

16-Pin DIP Top View

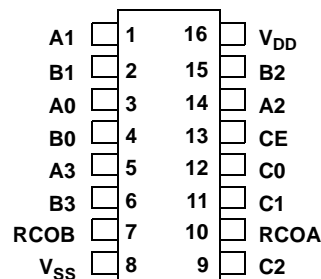

16-Lead Flatpack Top View

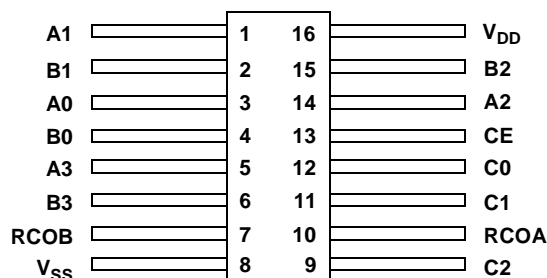

LOGIC SYMBOL

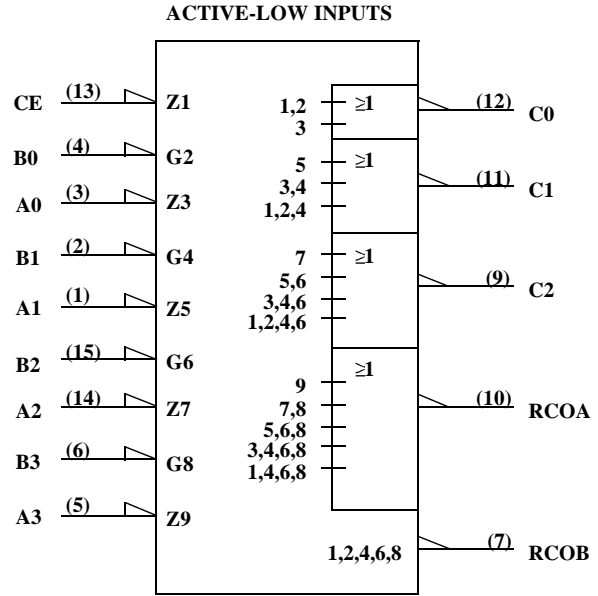
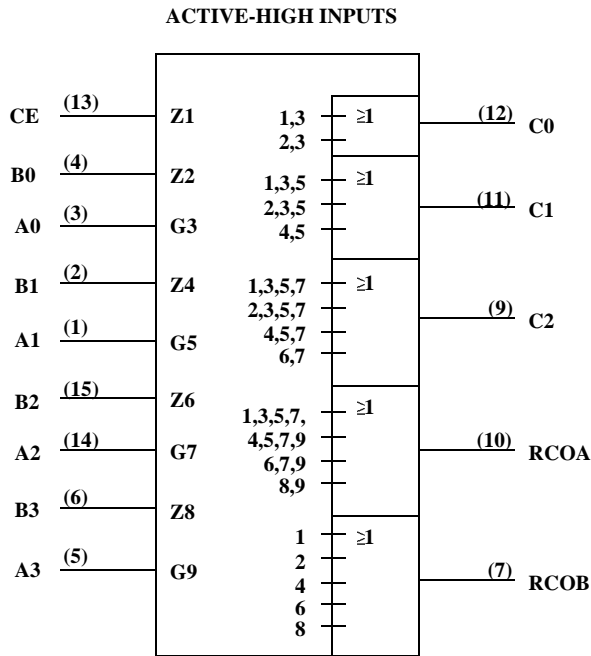

Notes:

- Logic symbols in accordance with ANSI/IEEE Std 91-1984 and IEC Publication 617-12.

FUNCTION TABLE FOR C0 OUTPUT

INPUTS			OUTPUT
A0	B0	CE	C0
H	H	X	H
H	X	H	H
L	X	X	L
X	L	L	L

FUNCTION TABLE FOR C1 OUTPUT

INPUTS					OUTPUT
A1	A0	B1	B0	CE	C1
H	X	H	X	X	H
H	H	X	H	X	H
H	H	X	X	H	H
L	X	X	X	X	L
X	L	L	X	X	L
X	X	L	L	L	L

FUNCTION TABLE FOR RCOB OUTPUT

INPUTS					OUTPUT
B3	B2	B1	B0	CE	RCOB
H	X	X	X	X	H
X	H	X	X	X	H
X	X	H	X	X	H
X	X	X	H	X	H
X	X	X	X	H	H
L	L	L	L	L	L

FUNCTION TABLE FOR C2 OUTPUT

INPUTS							OUTPUT
A2	A1	A0	B2	B1	B0	CE	C2
H	X	X	H	X	X	X	H
H	H	X	X	H	X	X	H
H	H	H	X	X	H	X	H
H	H	H	X	X	X	H	H
L	X	X	X	X	X	X	L
X	L	X	L	X	X	X	L
X	X	L	L	L	X	X	L
X	X	X	L	L	L	L	L

FUNCTION TABLE FOR RCOA OUTPUT

INPUTS								OUTPUT
A3	A2	A1	A0	B3	B2	B1	CE	RCOA
H	X	X	X	H	X	X	X	H
H	H	X	X	X	H	X	X	H
H	H	H	X	X	X	H	X	H
H	H	H	H	X	X	X	H	H
L	X	X	X	X	X	X	X	L
X	L	X	X	L	X	X	X	L
X	X	L	X	L	L	X	X	L
X	X	X	L	L	L	L	X	L
X	X	X	X	L	L	L	L	L

LOGIC DIAGRAM

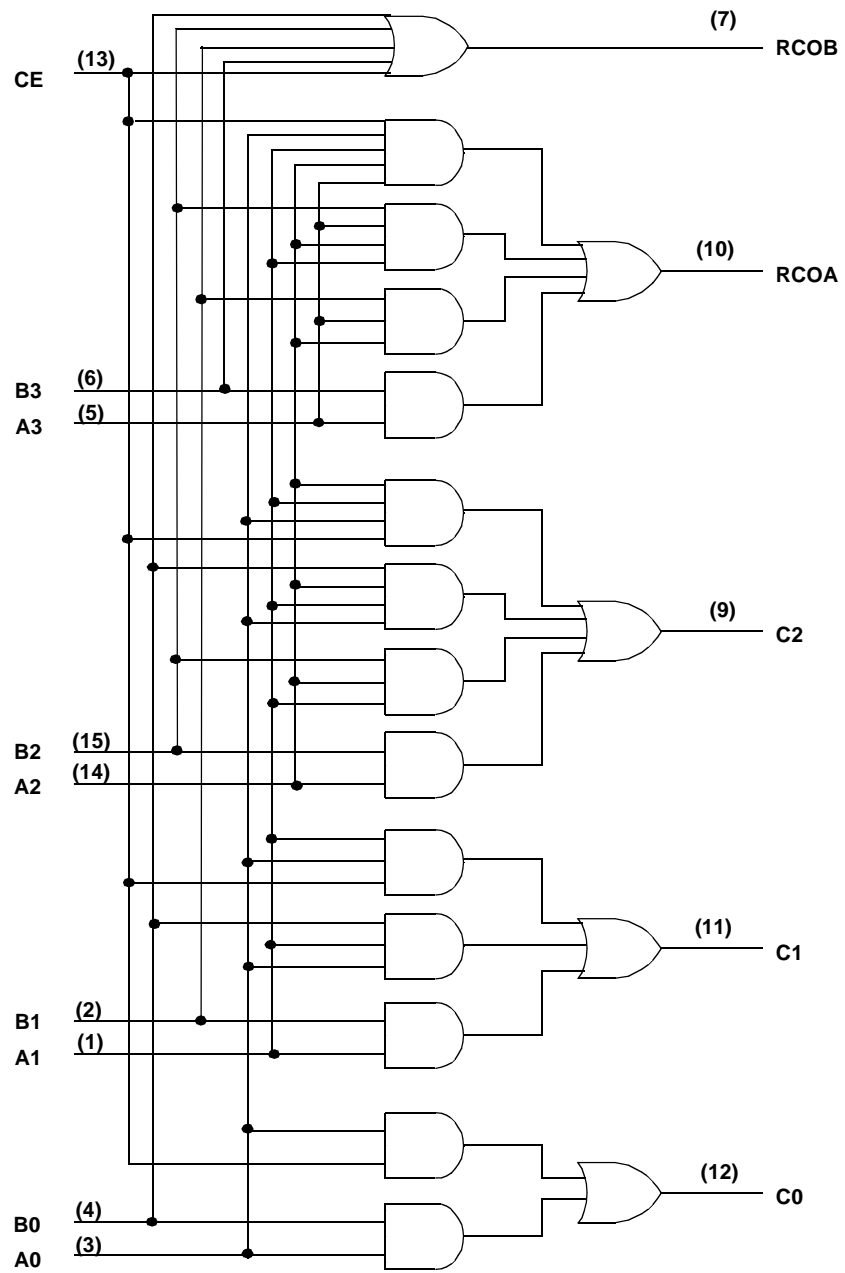

RADIATION HARDNESS SPECIFICATIONS ¹

PARAMETER	LIMIT	UNITS
Total Dose	1.0E6	rads(Si)
SEU Threshold ²	80	MeV-cm ² /mg
SEL Threshold	120	MeV-cm ² /mg
Neutron Fluence	1.0E14	n/cm ²

Notes:

- Logic will not latchup during radiation exposure within the limits defined in the table.
- Device storage elements are immune to SEU affects.

ABSOLUTE MAXIMUM RATINGS

SYMBOL	PARAMETER	LIMIT	UNITS
V _{DD}	Supply voltage	-0.3 to 7.0	V
V _{I/O}	Voltage any pin	-.3 to V _{DD} +.3	V
T _{STG}	Storage Temperature range	-65 to +150	°C
T _J	Maximum junction temperature	+175	°C
T _{LS}	Lead temperature (soldering 5 seconds)	+300	°C
Θ _{JC}	Thermal resistance junction to case	20	°C/W
I _I	DC input current	±10	mA
P _D	Maximum power dissipation	1	W

Note:

- Stresses outside the listed absolute maximum ratings may cause permanent damage to the device. This is a stress rating only, functional operation of the device at these or any other conditions beyond limits indicated in the operational sections is not recommended. Exposure to absolute maximum rating conditions for extended periods may affect device reliability.

RECOMMENDED OPERATING CONDITIONS

SYMBOL	PARAMETER	LIMIT	UNITS
V _{DD}	Supply voltage	4.5 to 5.5	V
V _{IN}	Input voltage any pin	0 to V _{DD}	V
T _C	Temperature range	-55 to + 125	°C

DC ELECTRICAL CHARACTERISTICS ⁷

($V_{DD} = 5.0V \pm 10\%$; $V_{SS} = 0V$ ⁶, $-55^{\circ}C < T_C < +125^{\circ}C$)

SYMBOL	PARAMETER	CONDITION	MIN	MAX	UNIT
V_{IL}	Low-level input voltage ¹ ACTS ACS			0.8 .3 V_{DD}	V
V_{IH}	High-level input voltage ¹ ACTS ACS		.5 V_{DD} .7 V_{DD}		V
I_{IN}	Input leakage current ACTS/ACS	$V_{IN} = V_{DD}$ or V_{SS}	-1	1	μA
V_{OL}	Low-level output voltage ³ ACTS ACS	$I_{OL} = 8mA$ $I_{OL} = 100\mu A$		0.40 0.25	V
V_{OH}	High-level output voltage ³ ACTS ACS	$I_{OH} = -8mA$ $I_{OH} = -100\mu A$.7 V_{DD} $V_{DD} - 0.25$		V
I_{OS}	Short-circuit output current ^{2,4} ACTS/ACS	$V_O = V_{DD}$ and V_{SS}	-200	200	mA
I_{OL}	Output current ¹⁰ (Sink)	$V_{IN} = V_{DD}$ or V_{SS} $V_{OL} = 0.4V$	8		mA
I_{OH}	Output current ¹⁰ (Source)	$V_{IN} = V_{DD}$ or V_{SS} $V_{OH} = V_{DD} - 0.4V$	-8		mA
P_{total}	Power dissipation ^{2,8,9}	$C_L = 50pF$		2.2	mW/ MHz
I_{DDQ}	Quiescent Supply Current	$V_{DD} = 5.5V$		10	μA
ΔI_{DDQ}	Quiescent Supply Current Delta ACTS	For input under test $V_{IN} = V_{DD} - 2.1V$ For all other inputs $V_{IN} = V_{DD}$ or V_{SS} $V_{DD} = 5.5V$		1.6	mA
C_{IN}	Input capacitance ⁵	$f = 1MHz @ 0V$		15	pF
C_{OUT}	Output capacitance ⁵	$f = 1MHz @ 0V$		15	pF

Notes:

1. Functional tests are conducted in accordance with MIL-STD-883 with the following input test conditions: $V_{IH} = V_{IH(min)} + 20\%$, $- 0\%$; $V_{IL} = V_{IL(max)} + 0\%$, $- 50\%$, as specified herein, for TTL, CMOS, or Schmitt compatible inputs. Devices may be tested using any input voltage within the above specified range, but are guaranteed to $V_{IH(min)}$ and $V_{IL(max)}$.
2. Supplied as a design limit but not guaranteed or tested.
3. Per MIL-PRF-38535, for current density $\leq 5.0E5$ amps/cm², the maximum product of load capacitance (per output buffer) times frequency should not exceed 3,765 pF/MHz.
4. Not more than one output may be shorted at a time for maximum duration of one second.
5. Capacitance measured for initial qualification and when design changes may affect the value. Capacitance is measured between the designated terminal and V_{SS} at frequency of 1MHz and a signal amplitude of 50mV rms maximum.
6. Maximum allowable relative shift equals 50mV.
7. All specifications valid for radiation dose $\leq 1E6$ rads(Si).
8. Power does not include power contribution of any TTL output sink current.
9. Power dissipation specified per switching output.
10. This value is guaranteed based on characterization data, but not tested.

AC ELECTRICAL CHARACTERISTICS ²

($V_{DD} = 5.0V \pm 10\%$; $V_{SS} = 0V$ ¹, $-55^{\circ}C < T_C < +125^{\circ}C$)

SYMBOL	PARAMETER	MINIMUM	MAXIMUM	UNIT
t_{PLH}	CE to C0, C1, C2	1	17	ns
t_{PHL}	CE to C0, C1, C2	1	16	ns
t_{PLH}	An or Bn to C0, C1, C2	1	15	ns
t_{PHL}	An or Bn to C0, C1, C2	1	17	ns
t_{PLH}	An, Bn or CE to RCOA	1	15	ns
t_{PHL}	An, Bn or CE to RCOA	1	15	ns
t_{PLH}	Bn or CE to RCOB	1	12	ns
t_{PHL}	Bn or CE to RCOB	1	15	ns

Notes:

1. Maximum allowable relative shift equals 50mV.
2. All specifications valid for radiation dose $\leq 1E6$ rads(Si).

UT54ACS273/UT54ACTS273

Radiation-Hardened Octal D-Flip-Flops with Clear

FEATURES

- Contains eight flip-flops with single-rail outputs
- Buffered clock and direct clear inputs
- Individual data input to each flip-flop
- Applications include:
 - Buffer/storage registers, shift registers, and pattern generators
- 1.2μ radiation-hardened CMOS
 - Latchup immune
- High speed
- Low power consumption
- Single 5 volt supply
- Available QML Q or V processes
- Flexible package
 - 20-pin DIP
 - 20-lead flatpack

DESCRIPTION

The UT54ACS273 and the UT54ACTS273 are positive-edge-triggered D-type flip-flops with a direct clear input.

Information at the D inputs meeting the setup time requirements is transferred to the Q outputs on the positive-going edge of the clock pulse. When the clock input is at either the high or low level, the D input signal has no effect at the output.

The devices are characterized over full military temperature range of -55°C to +125°C.

FUNCTION TABLE

INPUTS			OUTPUTS
$\overline{\text{CLR}}$	CLK	D _x	Q _x
L	X	X	L
H	↑	H	H
H	↑	L	L
H	L	X	No change

PINOUTS

20-Pin DIP Top View

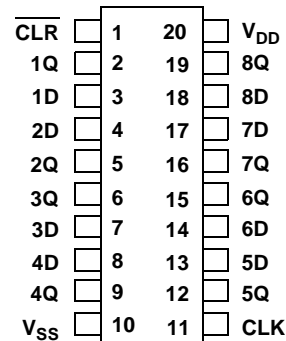

20-Lead Flatpack Top View

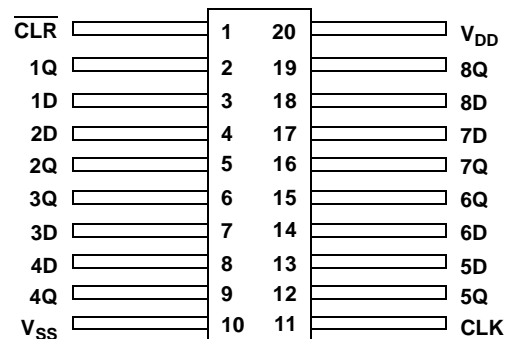

LOGIC SYMBOL

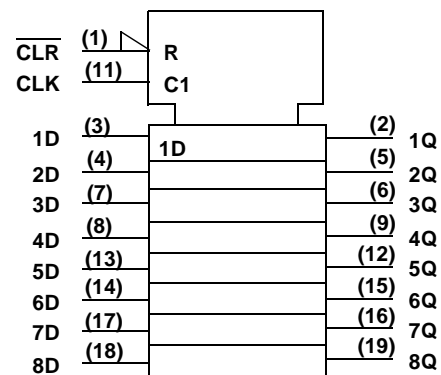

Note:

1. Logic symbol in accordance with ANSI/IEEE standard 91-1984 and IEC Publication 617-12.

LOGIC DIAGRAM

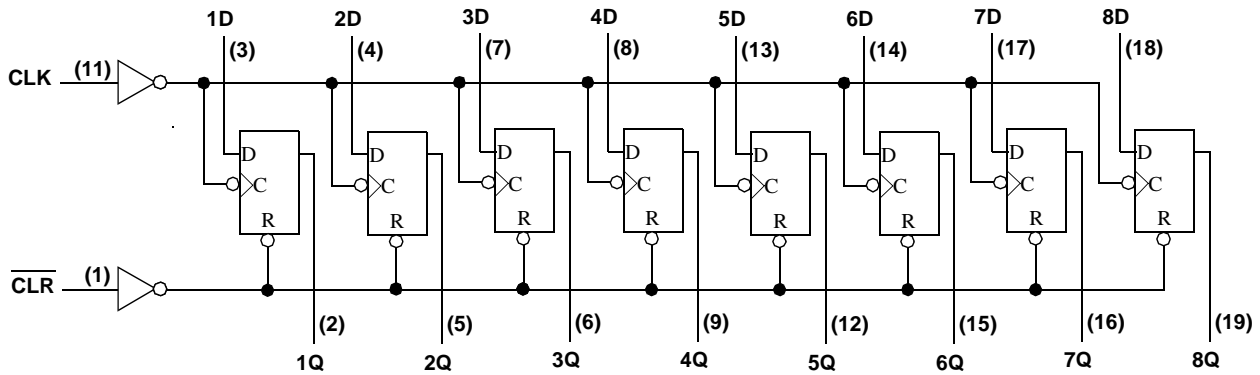

RADIATION HARDNESS SPECIFICATIONS ¹

PARAMETER	LIMIT	UNITS
Total Dose	1.0E6	rads(Si)
SEU Threshold ²	80	MeV-cm ² /mg
SEL Threshold	120	MeV-cm ² /mg
Neutron Fluence	1.0E14	n/cm ²

Notes:

1. Logic will not latchup during radiation exposure within the limits defined in the table.
2. Device storage elements are immune to SEU affects.

ABSOLUTE MAXIMUM RATINGS

SYMBOL	PARAMETER	LIMIT	UNITS
V _{DD}	Supply voltage	-0.3 to 7.0	V
V _{I/O}	Voltage any pin	-.3 to V _{DD} +.3	V
T _{STG}	Storage Temperature range	-65 to +150	°C
T _J	Maximum junction temperature	+175	°C
T _{LS}	Lead temperature (soldering 5 seconds)	+300	°C
Θ _{JC}	Thermal resistance junction to case	20	°C/W
I _I	DC input current	±10	mA
P _D	Maximum power dissipation	1	W

Note:

1. Stresses outside the listed absolute maximum ratings may cause permanent damage to the device. This is a stress rating only, functional operation of the device at these or any other conditions beyond limits indicated in the operational sections is not recommended. Exposure to absolute maximum rating conditions for extended periods may affect device reliability.

RECOMMENDED OPERATING CONDITIONS

SYMBOL	PARAMETER	LIMIT	UNITS
V_{DD}	Supply voltage	4.5 to 5.5	V
V_{IN}	Input voltage any pin	0 to V_{DD}	V
T_C	Temperature range	-55 to + 125	°C

DC ELECTRICAL CHARACTERISTICS ⁷(V_{DD} = 5.0V ±10%; V_{SS} = 0V ⁶, -55°C < T_C < +125 °C)

SYMBOL	PARAMETER	CONDITION	MIN	MAX	UNIT
V _{IL}	Low-level input voltage ¹ ACTS ACS			0.8 .3V _{DD}	V
V _{IH}	High-level input voltage ¹ ACTS ACS		.5V _{DD} .7V _{DD}		V
I _{IN}	Input leakage current ACTS/ACS	V _{IN} = V _{DD} or V _{SS}	-1	1	μA
V _{OL}	Low-level output voltage ³ ACTS ACS	I _{OL} = 8.0mA I _{OL} = 100μA		0.40 0.25	V
V _{OH}	High-level output voltage ³ ACTS ACS	I _{OH} = -8.0mA I _{OH} = -100μA	.7V _{DD} V _{DD} - 0.25		V
I _{OS}	Short-circuit output current ^{2,4} ACTS/ACS	V _O = V _{DD} and V _{SS}	-200	200	mA
I _{OL}	Output current ¹⁰ (Sink)	V _{IN} = V _{DD} or V _{SS} V _{OL} = 0.4V	8		mA
I _{OH}	Output current ¹⁰ (Source)	V _{IN} = V _{DD} or V _{SS} V _{OH} = V _{DD} - 0.4V	-8		mA
P _{total}	Power dissipation ^{2,8,9}	C _L = 50pF		1.9	mW/ MHz
I _{DDQ}	Quiescent Supply Current	V _{DD} = 5.5V		10	μA
ΔI _{DDQ}	Quiescent Supply Current Delta ACTS	For input under test V _{IN} = V _{DD} - 2.1V For all other inputs V _{IN} = V _{DD} or V _{SS} V _{DD} = 5.5V		1.6	mA
C _{IN}	Input capacitance ⁵	f = 1MHz @ 0V		15	pF
C _{OUT}	Output capacitance ⁵	f = 1MHz @ 0V		15	pF

UT54ACS273/UT54ACTS273

Notes:

1. Functional tests are conducted in accordance with MIL-STD-883 with the following input test conditions: $V_{IH} = V_{IH(min)} + 20\%$, $- 0\%$; $V_{IL} = V_{IL(max)} + 0\%$, $- 50\%$, as specified herein, for TTL, CMOS, or Schmitt compatible inputs. Devices may be tested using any input voltage within the above specified range, but are guaranteed to $V_{IH(min)}$ and $V_{IL(max)}$.
2. Supplied as a design limit but not guaranteed or tested.
3. Per MIL-PRF-38535, for current density $\leq 5.0E5$ amps/cm², the maximum product of load capacitance (per output buffer) times frequency should not exceed 3,765 pF/MHz.
4. Not more than one output may be shorted at a time for maximum duration of one second.
5. Capacitance measured for initial qualification and when design changes may affect the value. Capacitance is measured between the designated terminal and V_{SS} at frequency of 1MHz and a signal amplitude of 50mV rms maximum.
6. Maximum allowable relative shift equals 50mV.
7. All specifications valid for radiation dose $\leq 1E6$ rads(Si).
8. Power does not include power contribution of any TTL output sink current.
9. Power dissipation specified per switching output.
10. This value is guaranteed based on characterization data, but not tested.

AC ELECTRICAL CHARACTERISTICS ²(V_{DD} = 5.0V ±10%; V_{SS} = 0V ¹, -55°C < T_C < +125 °C)

SYMBOL	PARAMETER	MINIMUM	MAXIMUM	UNIT
t _{PLH}	CLK to Q	4	17	ns
t _{PHL}	CLK to Q	4	19	ns
t _{PHL}	$\overline{\text{CLR}}$ to Q	5	19	ns
f _{MAX}	Maximum clock frequency		63	MHz
t _{SU1}	$\overline{\text{CLR}}$ inactive setup time before CLK ↑	5		ns
t _{SU2}	Data setup time before CLK ↑	5		ns
t _H	Data hold time after CLK ↑	3		ns
t _w	Minimum pulse width $\overline{\text{CLR}}$ low CLK high CLK low	8		ns

Notes:

1. Maximum allowable relative shift equals 50mV.
2. All specifications valid for radiation dose ≤ 1E6 rads(Si).

UT54ACS279/UT54ACTS279

Radiation-Hardened Quadruple S-R Latches

FEATURES

- 1.2μ radiation-hardened CMOS
 - Latchup immune
- High speed
- Low power consumption
- Single 5 volt supply
- Available QML Q or V processes
- Flexible package
 - 16-pin DIP
 - 16-lead flatpack

DESCRIPTION

The UT54ACS279 and the UT54ACTS279 contain four basic \bar{S} - \bar{R} flip-flop latches. Under conventional operation, the \bar{S} - \bar{R} inputs are normally held high. When the \bar{S} input is pulsed low, the Q output will be set high. When \bar{R} is pulsed low, the Q output will be reset low. If the \bar{S} - \bar{R} inputs are taken low simultaneously, the Q output is unpredictable.

The devices are characterized over full military temperature range of -55°C to +125°C.

FUNCTION TABLE

INPUTS		OUTPUT
\bar{S}	\bar{R}	Q
H	H	Q_0
L	H	H
H	L	L
L	L	H^1

Note:

1. This configuration is nonstable. It may not persist when the \bar{S} and \bar{R} inputs return to their inactive (high) level.

LOGIC DIAGRAM

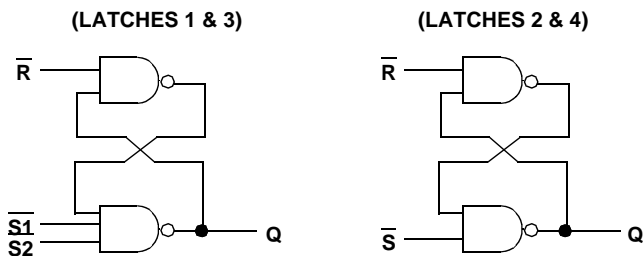

PINOUTS

16-Pin DIP Top View

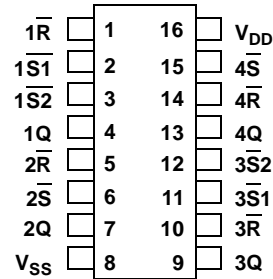

16-Lead Flatpack Top View

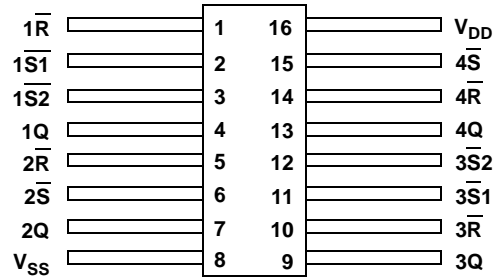

LOGIC SYMBOL

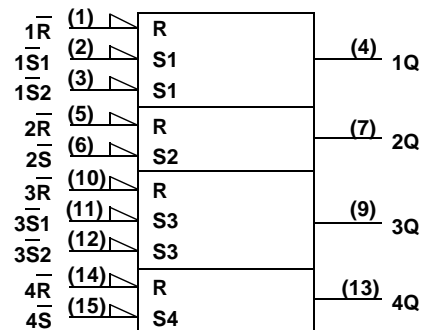

Note:

1. Logic symbol in accordance with ANSI/IEEE standard 91-1984 and IEC Publication 617-12.

RADIATION HARDNESS SPECIFICATIONS ¹

PARAMETER	LIMIT	UNITS
Total Dose	1.0E6	rads(Si)
SEU Threshold ²	80	MeV-cm ² /mg
SEL Threshold	120	MeV-cm ² /mg
Neutron Fluence	1.0E14	n/cm ²

Notes:

1. Logic will not latchup during radiation exposure within the limits defined in the table.
2. Device storage elements are immune to SEU affects.

ABSOLUTE MAXIMUM RATINGS

SYMBOL	PARAMETER	LIMIT	UNITS
V _{DD}	Supply voltage	-0.3 to 7.0	V
V _{I/O}	Voltage any pin	-.3 to V _{DD} +.3	V
T _{STG}	Storage Temperature range	-65 to +150	°C
T _J	Maximum junction temperature	+175	°C
T _{LS}	Lead temperature (soldering 5 seconds)	+300	°C
Θ _{JC}	Thermal resistance junction to case	20	°C/W
I _I	DC input current	±10	mA
P _D	Maximum power dissipation	1	W

Note:

1. Stresses outside the listed absolute maximum ratings may cause permanent damage to the device. This is a stress rating only, functional operation of the device at these or any other conditions beyond limits indicated in the operational sections is not recommended. Exposure to absolute maximum rating conditions for extended periods may affect device reliability.

RECOMMENDED OPERATING CONDITIONS

SYMBOL	PARAMETER	LIMIT	UNITS
V _{DD}	Supply voltage	4.5 to 5.5	V
V _{IN}	Input voltage any pin	0 to V _{DD}	V
T _C	Temperature range	-55 to + 125	°C

DC ELECTRICAL CHARACTERISTICS ⁷

($V_{DD} = 5.0V \pm 10\%$; $V_{SS} = 0V$ ⁶, $-55^{\circ}C < T_C < +125^{\circ}C$)

SYMBOL	PARAMETER	CONDITION	MIN	MAX	UNIT
V_{IL}	Low-level input voltage ¹ ACTS ACS			0.8 .3 V_{DD}	V
V_{IH}	High-level input voltage ¹ ACTS ACS		.5 V_{DD} .7 V_{DD}		V
I_{IN}	Input leakage current ACTS/ACS	$V_{IN} = V_{DD}$ or V_{SS}	-1	1	μA
V_{OL}	Low-level output voltage ³ ACTS ACS	$I_{OL} = 12.0mA$ $I_{OL} = 100\mu A$		0.40 0.25	V
V_{OH}	High-level output voltage ³ ACTS ACS	$I_{OH} = -12.0mA$ $I_{OH} = -100\mu A$.7 V_{DD} $V_{DD} - 0.25$		V
I_{OS}	Short-circuit output current ^{2,4} ACTS/ACS	$V_O = V_{DD}$ and V_{SS}	-300	300	mA
I_{OL}	Output current ¹⁰ (Sink)	$V_{IN} = V_{DD}$ or V_{SS} $V_{OL} = 0.4V$	12		mA
I_{OH}	Output current ¹⁰ (Source)	$V_{IN} = V_{DD}$ or V_{SS} $V_{OH} = V_{DD} - 0.4V$	-12		mA
P_{total}	Power dissipation ^{2,8,9}	$C_L = 50pF$		2.1	mW/ MHz
I_{DDQ}	Quiescent Supply Current	$V_{DD} = 5.5V$		10	μA
ΔI_{DDQ}	Quiescent Supply Current Delta ACTS	For input under test $V_{IN} = V_{DD} - 2.1V$ For all other inputs $V_{IN} = V_{DD}$ or V_{SS} $V_{DD} = 5.5V$		1.6	mA
C_{IN}	Input capacitance ⁵	$f = 1MHz @ 0V$		15	pF
C_{OUT}	Output capacitance ⁵	$f = 1MHz @ 0V$		15	pF

Notes:

1. Functional tests are conducted in accordance with MIL-STD-883 with the following input test conditions: $V_{IH} = V_{IH(min)} + 20\%$, $- 0\%$; $V_{IL} = V_{IL(max)} + 0\%$, $- 50\%$, as specified herein, for TTL, CMOS, or Schmitt compatible inputs. Devices may be tested using any input voltage within the above specified range, but are guaranteed to $V_{IH(min)}$ and $V_{IL(max)}$.
2. Supplied as a design limit but not guaranteed or tested.
3. Per MIL-PRF-38535, for current density $\leq 5.0E5$ amps/cm², the maximum product of load capacitance (per output buffer) times frequency should not exceed 3,765 pF/MHz.
4. Not more than one output may be shorted at a time for maximum duration of one second.
5. Capacitance measured for initial qualification and when design changes may affect the value. Capacitance is measured between the designated terminal and V_{SS} at frequency of 1MHz and a signal amplitude of 50mV rms maximum.
6. Maximum allowable relative shift equals 50mV.
7. All specifications valid for radiation dose $\leq 1E6$ rads(Si).
8. Power does not include power contribution of any TTL output sink current.
9. Power dissipation specified per switching output.
10. This value is guaranteed based on characterization data, but not tested.

AC ELECTRICAL CHARACTERISTICS ²

($V_{DD} = 5.0V \pm 10\%$; $V_{SS} = 0V$ ¹, $-55^{\circ}C < T_C < +125^{\circ}C$)

SYMBOL	PARAMETER	MINIMUM	MAXIMUM	UNIT
t_{PLH}	\bar{S} to Q	1	15	ns
t_{PHL}	\bar{S} to Q	1	18	ns
t_{PHL}	\bar{R} to Q	1	17	ns
t_w	Minimum pulse width \bar{S} low \bar{R} low	8		ns

Notes:

1. Maximum allowable relative shift equals 50mV.
2. All specifications valid for radiation dose $\leq 1E6$ rads(Si).

UT54ACS280/UT54ACTS280

Radiation-Hardened 9-Bit Parity Generators/Checkers

FEATURES

- Generates either odd or even parity for nine data lines
- Cascadable for n-bits parity
- 1.2 μ radiation-hardened CMOS
 - Latchup immune
- High speed
- Low power consumption
- Single 5 volt supply
- Available QML Q or V processes
- Flexible package
 - 14-pin DIP
 - 14-lead flatpack

DESCRIPTION

The UT54ACS280 and the UT54ACTS280 are 9-bit parity generators/checkers that use high-performance circuitry and features odd and even outputs to facilitate operation of either odd or even parity application. The word-length capability is easily expanded by cascading.

The devices are characterized over full military temperature range of -55°C to +125°C.

FUNCTION TABLE

NUMBER OF INPUTS A THRU I THAT ARE HIGH	OUTPUT	
	Σ EVEN	Σ ODD
0,2,4,6,8	H	L
1,3,5,7,9	L	H

LOGIC SYMBOL

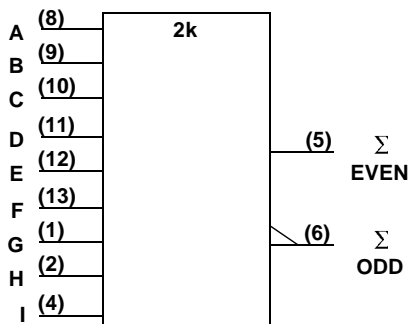

Note:

1. Logic symbol in accordance with ANSI/IEEE standard 91-1984 and IEC Publication 617-12.

PINOUTS

14-Pin DIP Top View

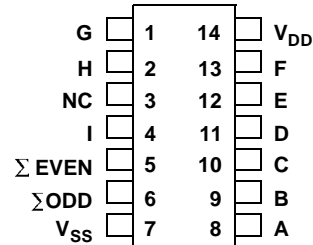

14-Lead Flatpack Top View

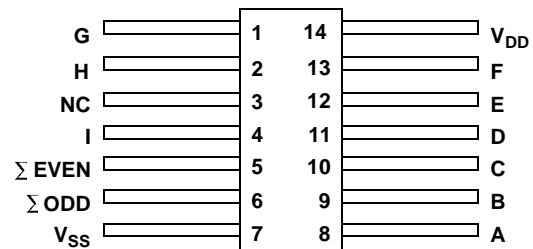

LOGIC DIAGRAM

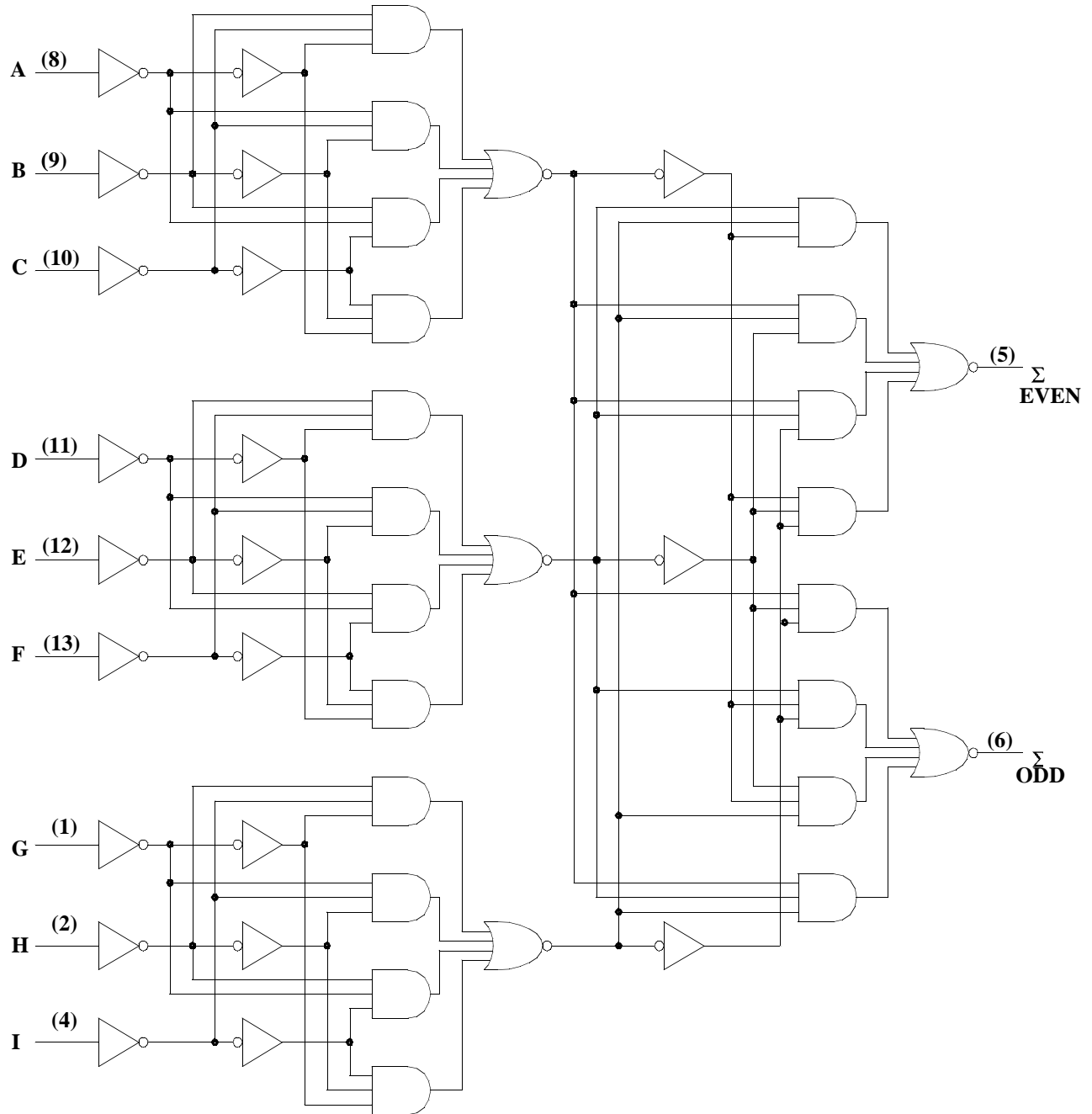

RADIATION HARDNESS SPECIFICATIONS ¹

PARAMETER	LIMIT	UNITS
Total Dose	1.0E6	rads(Si)
SEU Threshold ²	80	MeV-cm ² /mg
SEL Threshold	120	MeV-cm ² /mg
Neutron Fluence	1.0E14	n/cm ²

Notes:

1. Logic will not latchup during radiation exposure within the limits defined in the table.
2. Device storage elements are immune to SEU affects.

ABSOLUTE MAXIMUM RATINGS

SYMBOL	PARAMETER	LIMIT	UNITS
V _{DD}	Supply voltage	-0.3 to 7.0	V
V _{I/O}	Input voltage any pin	-.3 to V _{DD} +.3	V
T _{STG}	Storage Temperature range	-65 to +150	°C
T _J	Maximum junction temperature	+175	°C
T _{LS}	Lead temperature (soldering 5 seconds)	+300	°C
Θ _{JC}	Thermal resistance junction to case	20	°C/W
I _I	DC input current	±10	mA
P _D	Maximum power dissipation	1	W

Note:

1. Stresses outside the listed absolute maximum ratings may cause permanent damage to the device. This is a stress rating only, functional operation of the device at these or any other conditions beyond limits indicated in the operational sections is not recommended. Exposure to absolute maximum rating conditions for extended periods may affect device reliability.

RECOMMENDED OPERATING CONDITIONS

SYMBOL	PARAMETER	LIMIT	UNITS
V _{DD}	Supply voltage	4.5 to 5.5	V
V _{IN}	Input voltage any pin	0 to V _{DD}	V
T _C	Temperature range	-55 to + 125	°C

DC ELECTRICAL CHARACTERISTICS ⁷(V_{DD} = 5.0V ±10%; V_{SS} = 0V ⁶, -55 °C < T_C < +125°C)

SYMBOL	PARAMETER	CONDITION	MIN	MAX	UNIT
V _{IL}	Low-level input voltage ¹ ACTS ACS			0.8 .3V _{DD}	V
V _{IH}	High-level input voltage ¹ ACTS ACS		.5V _{DD} .7V _{DD}		V
I _{IN}	Input leakage current ACTS/ACS	V _{IN} = V _{DD} or V _{SS}	-1	1	μA
V _{OL}	Low-level output voltage ³ ACTS ACS	I _{OL} = 8.0mA I _{OL} = 100μA		0.40 0.25	V
V _{OH}	High-level output voltage ³ ACTS ACS	I _{OH} = -8.0mA I _{OH} = -100μA	.7V _{DD} V _{DD} - 0.25		V
I _{OS}	Short-circuit output current ^{2,4} ACTS/ACS	V _O = V _{DD} and V _{SS}	-200	200	mA
I _{OL}	Output current ¹⁰ (Sink)	V _{IN} = V _{DD} or V _{SS} V _{OL} = 0.4V	8		mA
I _{OH}	Output current ¹⁰ (Source)	V _{IN} = V _{DD} or V _{SS} V _{OH} = V _{DD} - 0.4V	-8		mA
P _{total}	Power dissipation ^{2,8,9}	C _L = 50pF		2.2	mW/ MHz
I _{DDQ}	Quiescent Supply Current	V _{DD} = 5.5V		10	μA
ΔI _{DDQ}	Quiescent Supply Current Delta ACTS	For input under test V _{IN} = V _{DD} - 2.1V For all other inputs V _{IN} = V _{DD} or V _{SS} V _{DD} = 5.5V		1.6	mA
C _{IN}	Input capacitance ⁵	f = 1MHz @ 0V		15	pF
C _{OUT}	Output capacitance ⁵	f = 1MHz @ 0V		15	pF

UT54ACS280/UT54ACTS280

Notes:

1. Functional tests are conducted in accordance with MIL-STD-883 with the following input test conditions: $V_{IH} = V_{IH(min)} + 20\%$, $- 0\%$; $V_{IL} = V_{IL(max)} + 0\%$, $- 50\%$, as specified herein, for TTL, CMOS, or Schmitt compatible inputs. Devices may be tested using any input voltage within the above specified range, but are guaranteed to $V_{IH(min)}$ and $V_{IL(max)}$.
2. Supplied as a design limit but not guaranteed or tested.
3. Per MIL-PRF-38535, for current density $\leq 5.0E5$ amps/cm², the maximum product of load capacitance (per output buffer) times frequency should not exceed 3,765 pF/MHz.
4. Not more than one output may be shorted at a time for maximum duration of one second.
5. Capacitance measured for initial qualification and when design changes may affect the value. Capacitance is measured between the designated terminal and V_{SS} at frequency of 1MHz and a signal amplitude of 50mV rms maximum.
6. Maximum allowable relative shift equals 50mV.
7. All specifications valid for radiation dose $\leq 1E6$ rads(Si).
8. Power does not include power contribution of any TTL output sink current.
9. Power dissipation specified per switching output.
10. This value is guaranteed based on characterization data, but not tested.

AC ELECTRICAL CHARACTERISTICS ²(V_{DD} = 5.0V ±10%; V_{SS} = 0V ¹, -55 °C < T_C < +125°C)

SYMBOL	PARAMETER	MINIMUM	MAXIMUM	UNIT
t _{PLH}	Any input to Σ even	1	20	ns
t _{PHL}	Any input to Σ even	1	20	ns
t _{PHL}	Any input to Σ odd	1	22	ns
t _{PLH}	Any input to Σ odd	1	20	ns

Notes:

1. Maximum allowable relative shift equals 50mV.
2. All specifications valid for radiation dose ≤ 1E6 rads(Si).

UT54ACS283/UT54ACTS283

Radiation-Hardened 4-Bit Binary Full Adders

FEATURES

- 1.2 μ radiation-hardened CMOS
 - Latchup immune
- High speed
- Low power consumption
- Single 5 volt supply
- Available QML Q or V processes
- Flexible package
 - 16-pin DIP
 - 16-lead flatpack

DESCRIPTION

The UT54ACS283 and the UT54ACTS283 are 4-bit binary adders. The adders perform addition of two 4-bit binary words. The sum (Σ) outputs are provided for each bit and the resultant carry (C4) is obtained as the fifth bit. The adders feature full internal look-ahead across all four bits for fast carry generation.

The devices are characterized over full military temperature range of -55°C to +125°C.

LOGIC SYMBOL

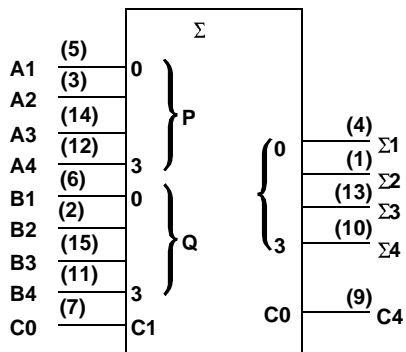

Note:

1. Logic symbol in accordance with ANSI/IEEE Std 91-1984 and IEC Publication 617-12.

PINOUTS

16-Pin DIP Top View

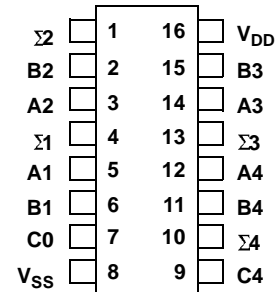

16-Lead Flatpack Top View

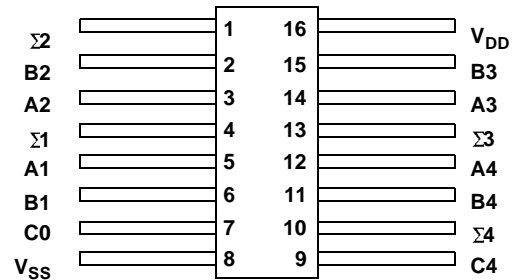

FUNCTION TABLE

INPUT								OUTPUT															
								When C0 = L				When C2 = L				When C0 = H				When C2 = H			
A1	A3	B1	B3	A2	A4	B2	B4	$\Sigma 1$	$\Sigma 3$	$\Sigma 2$	$\Sigma 4$	C2	C4	$\Sigma 1$	$\Sigma 3$	$\Sigma 2$	$\Sigma 4$	C2	C4				
L	L	L	L	L	L	L	L	L	L	L	L	L	L	H	L	L	L	L	L				
H	L	L	L	L	L	L	L	H	L	L	L	L	L	L	H	L	L	L	L				
L	H	L	L	L	L	L	L	H	L	L	L	L	L	L	H	L	L	L	L				
H	H	L	L	L	L	L	L	L	H	L	L	L	L	H	H	L	L	L	L				
L	L	H	L	L	L	L	L	L	H	L	L	L	L	H	H	L	L	L	L				
H	L	H	L	L	L	L	L	H	H	L	L	L	L	L	L	L	L	L	H				
L	H	H	L	L	L	L	L	H	H	L	L	L	L	L	L	L	L	L	H				
H	H	H	L	L	L	L	L	L	L	L	L	H	L	H	L	L	L	L	H				
L	L	L	H	L	L	L	L	L	H	L	L	L	L	H	H	L	L	L	L				
H	L	L	H	L	L	L	L	H	H	L	L	L	L	L	L	L	L	L	H				
L	H	L	H	L	L	L	L	H	H	L	L	L	L	H	L	L	L	L	H				
H	L	H	H	L	L	L	L	L	L	L	L	H	L	H	L	L	L	L	H				
L	L	H	H	L	L	L	L	L	L	L	L	H	L	H	L	L	L	L	H				
H	L	H	H	L	L	L	L	H	L	L	L	H	L	L	H	L	L	L	H				
L	H	H	H	L	L	L	L	H	L	L	L	H	L	L	H	L	L	L	H				
H	H	H	H	L	L	L	L	L	H	L	L	H	L	H	L	L	L	L	H				

H = high level, L = low level

Note:

Input conditions at A1, A2, B1, B2, and C0 are used to determine outputs $\Sigma 1$ and $\Sigma 2$ and the value of the internal carry C2. The values at C2, A3, B3, A4, and B4 are then used to determine outputs $\Sigma 3$, $\Sigma 4$, and C4.

LOGIC DIAGRAM

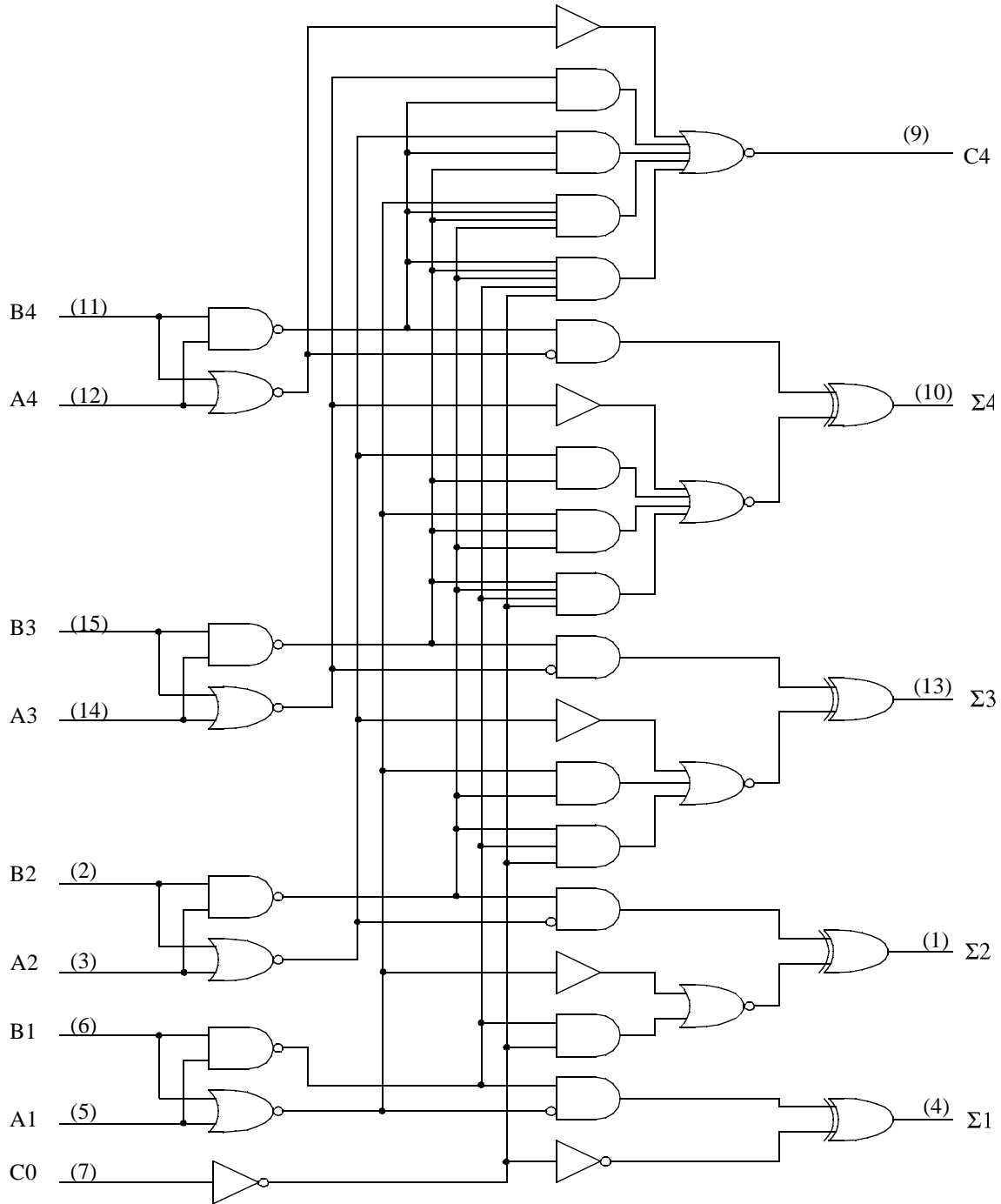

RADIATION HARDNESS SPECIFICATIONS ¹

PARAMETER	LIMIT	UNITS
Total Dose	1.0E6	rads(Si)
SEU Threshold ²	80	MeV-cm ² /mg
SEL Threshold	120	MeV-cm ² /mg
Neutron Fluence	1.0E14	n/cm ²

Notes:

- Logic will not latchup during radiation exposure within the limits defined in the table.
- Device storage elements are immune to SEU affects.

ABSOLUTE MAXIMUM RATINGS

SYMBOL	PARAMETER	LIMIT	UNITS
V _{DD}	Supply voltage	-0.3 to 7.0	V
V _{I/O}	Voltage any pin	-.3 to V _{DD} +.3	V
T _{STG}	Storage Temperature range	-65 to +150	°C
T _J	Maximum junction temperature	+175	°C
T _{LS}	Lead temperature (soldering 5 seconds)	+300	°C
Θ _{JC}	Thermal resistance junction to case	20	°C/W
I _I	DC input current	±10	mA
P _D	Maximum power dissipation	1	W

Note:

- Stresses outside the listed absolute maximum ratings may cause permanent damage to the device. This is a stress rating only, functional operation of the device at these or any other conditions beyond limits indicated in the operational sections is not recommended. Exposure to absolute maximum rating conditions for extended periods may affect device reliability.

RECOMMENDED OPERATING CONDITIONS

SYMBOL	PARAMETER	LIMIT	UNITS
V _{DD}	Supply voltage	4.5 to 5.5	V
V _{IN}	Input voltage any pin	0 to V _{DD}	V
T _C	Temperature range	-55 to + 125	°C

DC ELECTRICAL CHARACTERISTICS ⁷

($V_{DD} = 5.0V \pm 10\%$; $V_{SS} = 0V$ ⁶, $-55^{\circ}C < T_C < +125^{\circ}C$)

SYMBOL	PARAMETER	CONDITION	MIN	MAX	UNIT
V_{IL}	Low-level input voltage ¹ ACTS ACS			0.8 .3 V_{DD}	V
V_{IH}	High-level input voltage ¹ ACTS ACS		.5 V_{DD} .7 V_{DD}		V
I_{IN}	Input leakage current ACTS/ACS	$V_{IN} = V_{DD}$ or V_{SS}	-1	1	μA
V_{OL}	Low-level output voltage ³ ACTS ACS	$I_{OL} = 8.0mA$ $I_{OL} = 100\mu A$		0.40 0.25	V
V_{OH}	High-level output voltage ³ ACTS ACS	$I_{OH} = -8.0mA$ $I_{OH} = -100\mu A$.7 V_{DD} $V_{DD} - 0.25$		V
I_{OS}	Short-circuit output current ^{2,4} ACTS/ACS	$V_O = V_{DD}$ and V_{SS}	-200	200	mA
I_{OL}	Output current ¹⁰ (Sink)	$V_{IN} = V_{DD}$ or V_{SS} $V_{OL} = 0.4V$	8		mA
I_{OH}	Output current ¹⁰ (Source)	$V_{IN} = V_{DD}$ or V_{SS} $V_{OH} = V_{DD} - 0.4V$	-8		mA
P_{total}	Power dissipation ^{2,8,9}	$C_L = 50pF$		1.9	mW/ MHz
I_{DDQ}	Quiescent Supply Current	$V_{DD} = 5.5V$		10	μA
ΔI_{DDQ}	Quiescent Supply Current Delta ACTS	For input under test $V_{IN} = V_{DD} - 2.1V$ For all other inputs $V_{IN} = V_{DD}$ or V_{SS} $V_{DD} = 5.5V$		1.6	mA
C_{IN}	Input capacitance ⁵	$f = 1MHz @ 0V$		15	pF
C_{OUT}	Output capacitance ⁵	$f = 1MHz @ 0V$		15	pF

Notes:

1. Functional tests are conducted in accordance with MIL-STD-883 with the following input test conditions: $V_{IH} = V_{IH(min)} + 20\%$, $- 0\%$; $V_{IL} = V_{IL(max)} + 0\%$, $- 50\%$, as specified herein, for TTL, CMOS, or Schmitt compatible inputs. Devices may be tested using any input voltage within the above specified range, but are guaranteed to $V_{IH(min)}$ and $V_{IL(max)}$.
2. Supplied as a design limit but not guaranteed or tested.
3. Per MIL-PRF-38535, for current density $\leq 5.0E5$ amps/cm², the maximum product of load capacitance (per output buffer) times frequency should not exceed 3,765 pF/MHz.
4. Not more than one output may be shorted at a time for maximum duration of one second.
5. Capacitance measured for initial qualification and when design changes may affect the value. Capacitance is measured between the designated terminal and V_{SS} at frequency of 1MHz and a signal amplitude of 50mV rms maximum.
6. Maximum allowable relative shift equals 50mV.
7. All specifications valid for radiation dose $\leq 1E6$ rads(Si).
8. Power does not include power contribution of any TTL output sink current.
9. Power dissipation specified per switching output.
10. This value is guaranteed based on characterization data, but not tested.

AC ELECTRICAL CHARACTERISTICS ²

($V_{DD} = 5.0V \pm 10\%$; $V_{SS} = 0V$ ¹, $-55^{\circ}C < T_C < +125^{\circ}C$)

SYMBOL	PARAMETER	MINIMUM	MAXIMUM	UNIT
t _{PLH}	Propagation delay C0 to Σn	2	16	ns
t _{PHL}	Propagation delay C0 to Σn	2	19	ns
t _{PLH}	Propagation delay C0 to C4	2	16	ns
t _{PHL}	Propagation delay C0 to C4	2	17	ns
t _{PLH}	Propagation delay An, Bn to C4	2	16	ns
t _{PHL}	Propagation delay An, Bn to C4	2	15	ns
t _{PLH}	Propagation delay An, Bn to Σn	2	14	ns
t _{PHL}	Propagation delay An, Bn to Σn	2	16	ns

Notes:

1. Maximum allowable relative shift equals 50mV.
2. All specifications valid for radiation dose $\leq 1E6$ rads(Si).

UT54ACS365/UT54ACTS365

Radiation-Hardened Hex Buffers/Line Drivers with Three-State Outputs

FEATURES

- 1.2μ radiation-hardened CMOS
 - Latchup immune
- High speed
- Low power consumption
- Single 5 volt supply
- Available QML Q or V processes
- Flexible package
 - 16-pin DIP
 - 16-lead flatpack

DESCRIPTION

The UT54ACS365 and UT54ACTS365 are non-inverting hex buffer and line driver with three-state outputs. The output enables ($\overline{OE1}$ and $\overline{OE2}$) control the three-state outputs. If $\overline{OE1}$ or $\overline{OE2}$ is high, the outputs will be in a high impedance state. For data, both $\overline{OE1}$ and $\overline{OE2}$ must be low.

The devices are characterized over full military temperature range of -55°C to +125°C.

FUNCTION TABLE

INPUTS		OUTPUT	
$\overline{OE1}$	$\overline{OE2}$	A	Y
L	L	L	L
L	L	H	H
X	H	X	Z
H	X	X	Z

LOGIC SYMBOL

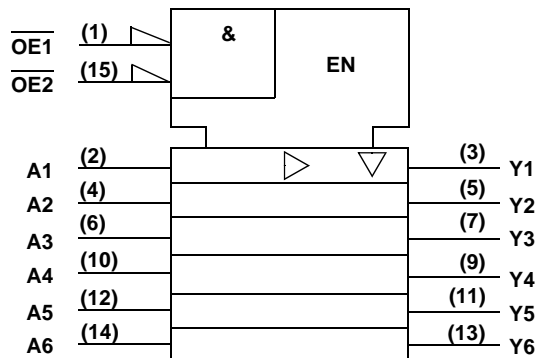

Note:

1. Logic symbol in accordance with ANSI/IEEE Std 91-1984 and IEC Publication 617-12.

PINOUTS

16-Pin DIP Top View

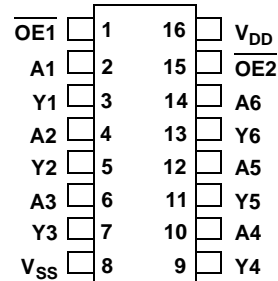

16-Lead Flatpack Top View

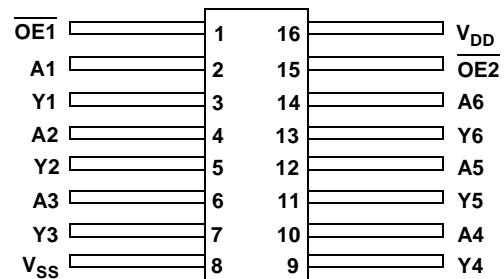

LOGIC DIAGRAM

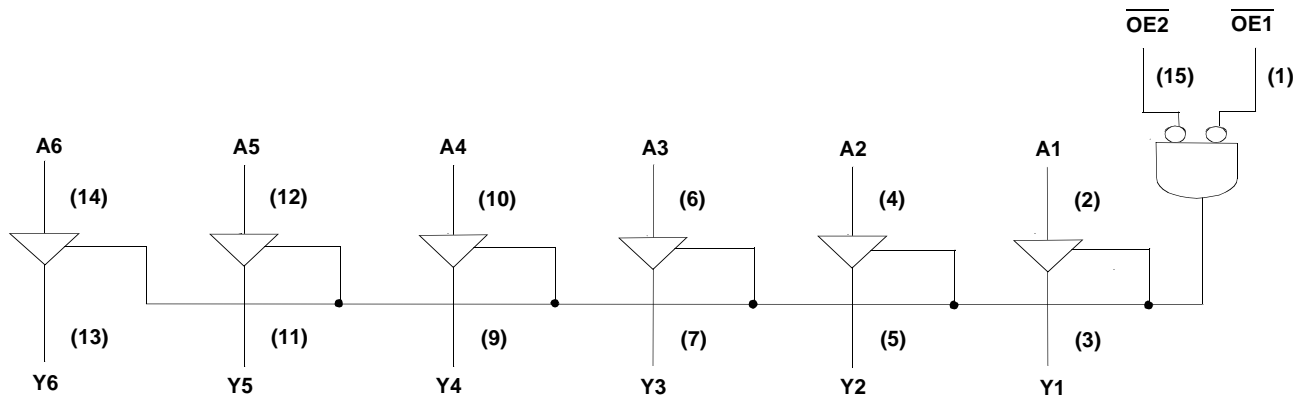

RADIATION HARDNESS SPECIFICATIONS ¹

PARAMETER	LIMIT	UNITS
Total Dose	1.0E6	rads(Si)
SEU Threshold ²	80	MeV-cm ² /mg
SEL Threshold	120	MeV-cm ² /mg
Neutron Fluence	1.0E14	n/cm ²

Notes:

1. Logic will not latchup during radiation exposure within the limits defined in the table.
2. Device storage elements are immune to SEU affects.

ABSOLUTE MAXIMUM RATINGS

SYMBOL	PARAMETER	LIMIT	UNITS
V _{DD}	Supply voltage	-0.3 to 7.0	V
V _{I/O}	Voltage any pin	-.3 to V _{DD} +.3	V
T _{STG}	Storage Temperature range	-65 to +150	°C
T _J	Maximum junction temperature	+175	°C
T _{LS}	Lead temperature (soldering 5 seconds)	+300	°C
Θ _{JC}	Thermal resistance junction to case	20	°C/W
I _I	DC input current	±10	mA
P _D	Maximum power dissipation	1	W

Note:

1. Stresses outside the listed absolute maximum ratings may cause permanent damage to the device. This is a stress rating only, functional operation of the device at these or any other conditions beyond limits indicated in the operational sections is not recommended. Exposure to absolute maximum rating conditions for extended periods may affect device reliability.

RECOMMENDED OPERATING CONDITIONS

SYMBOL	PARAMETER	LIMIT	UNITS
V_{DD}	Supply voltage	4.5 to 5.5	V
V_{IN}	Input voltage any pin	0 to V_{DD}	V
T_C	Temperature range	-55 to + 125	°C

DC ELECTRICAL CHARACTERISTICS ⁷(V_{DD} = 5.0V ±10%; V_{SS} = 0V ⁶, -55 °C < T_C < +125°C)

SYMBOL	PARAMETER	CONDITION	MIN	MAX	UNIT
V _{IL}	Low-level input voltage ¹ ACTS ACS			0.8 .3V _{DD}	V
V _{IH}	High-level input voltage ¹ ACTS ACS		.5V _{DD} .7V _{DD}		V
I _{IN}	Input leakage current ACTS/ACS	V _{IN} = V _{DD} or V _{SS}	-1	1	μA
V _{OL}	Low-level output voltage ³ ACTS ACS	I _{OL} = 12.0mA I _{OL} = 100μA		0.40 0.25	V
V _{OH}	High-level output voltage ³ ACTS ACS	I _{OH} = -12.0mA I _{OH} = -100μA	.7V _{DD} V _{DD} - 0.25		V
I _{OZ}	Three-state output leakage current	V _O = V _{DD} and V _{SS}	-30	30	μA
I _{OS}	Short-circuit output current ^{2,4} ACTS/ACS	V _O = V _{DD} and V _{SS}	-300	300	mA
I _{OL}	Output current ¹⁰ (Sink)	V _{IN} = V _{DD} or V _{SS} V _{OL} = 0.4V	12		mA
I _{OH}	Output current ¹⁰ (Source)	V _{IN} = V _{DD} or V _{SS} V _{OH} = V _{DD} - 0.4V	-12		mA
P _{total}	Power dissipation ^{2, 8, 9}	C _L = 50pF		1.8	mW/ MHz
I _{DDQ}	Quiescent Supply Current	V _{DD} = 5.5V		10	μA
ΔI _{DDQ}	Quiescent Supply Current Delta ACTS	For input under test V _{IN} = V _{DD} - 2.1V For all other inputs V _{IN} = V _{DD} or V _{SS} V _{DD} = 5.5V		1.6	mA
C _{IN}	Input capacitance ⁵	f = 1MHz @ 0V		15	pF
C _{OUT}	Output capacitance ⁵	f = 1MHz @ 0V		15	pF

UT54ACS365/UT54ACTS365

Notes:

1. Functional tests are conducted in accordance with MIL-STD-883 with the following input test conditions: $V_{IH} = V_{IH(min)} + 20\%$, $- 0\%$; $V_{IL} = V_{IL(max)} + 0\%$, $- 50\%$, as specified herein, for TTL, CMOS, or Schmitt compatible inputs. Devices may be tested using any input voltage within the above specified range, but are guaranteed to $V_{IH(min)}$ and $V_{IL(max)}$.
2. Supplied as a design limit but not guaranteed or tested.
3. Per MIL-PRF-38535, for current density $\leq 5.0E5$ amps/cm², the maximum product of load capacitance (per output buffer) times frequency should not exceed 3,765 pF/MHz.
4. Not more than one output may be shorted at a time for maximum duration of one second.
5. Capacitance measured for initial qualification and when design changes may affect the value. Capacitance is measured between the designated terminal and V_{SS} at frequency of 1MHz and a signal amplitude of 50mV rms maximum.
6. Maximum allowable relative shift equals 50mV.
7. All specifications valid for radiation dose $\leq 1E6$ rads(Si).
8. Power does not include power contribution of any TTL output sink current.
9. Power dissipation specified per switching output.
10. This value is guaranteed based on characterization data, but not tested.

AC ELECTRICAL CHARACTERISTICS ²(V_{DD} = 5.0V ±10%; V_{SS} = 0V ¹, -55 °C < T_C < +125°C)

SYMBOL	PARAMETER	MINIMUM	MAXIMUM	UNIT
t _{PLH}	Data to output	2	11	ns
t _{PHL}	Data to output	2	13	ns
t _{PZL}	$\overline{\text{OE}}$ low to output active	2	14	ns
t _{PZH}	$\overline{\text{OE}}$ low to output active	2	15	ns
t _{PLZ}	$\overline{\text{OE}}$ high to output three-state	2	12	ns
t _{PHZ}	$\overline{\text{OE}}$ high to output three-state	2	14	ns

Notes:

1. Maximum allowable relative shift equals 50mV.
2. All specifications valid for radiation dose ≤ 1E6 rads(Si).

UT54ACS365/UT54ACTS365

Radiation-Hardened Hex Buffers/Line Drivers with Three-State Outputs

FEATURES

- 1.2μ radiation-hardened CMOS
 - Latchup immune
- High speed
- Low power consumption
- Single 5 volt supply
- Available QML Q or V processes
- Flexible package
 - 16-pin DIP
 - 16-lead flatpack

DESCRIPTION

The UT54ACS365 and UT54ACTS365 are non-inverting hex buffer and line driver with three-state outputs. The output enables ($\overline{OE1}$ and $\overline{OE2}$) control the three-state outputs. If $\overline{OE1}$ or $\overline{OE2}$ is high, the outputs will be in a high impedance state. For data, both $\overline{OE1}$ and $\overline{OE2}$ must be low.

The devices are characterized over full military temperature range of -55°C to +125°C.

FUNCTION TABLE

INPUTS		OUTPUT	
$\overline{OE1}$	$\overline{OE2}$	A	Y
L	L	L	L
L	L	H	H
X	H	X	Z
H	X	X	Z

LOGIC SYMBOL

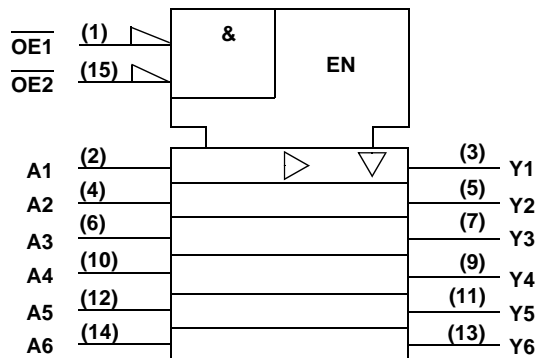

Note:

1. Logic symbol in accordance with ANSI/IEEE Std 91-1984 and IEC Publication 617-12.

PINOUTS

16-Pin DIP Top View

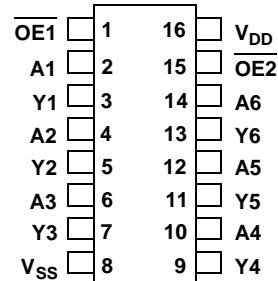

16-Lead Flatpack Top View

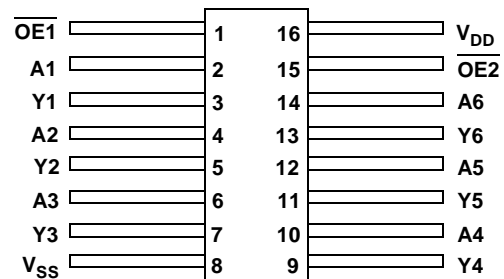

LOGIC DIAGRAM

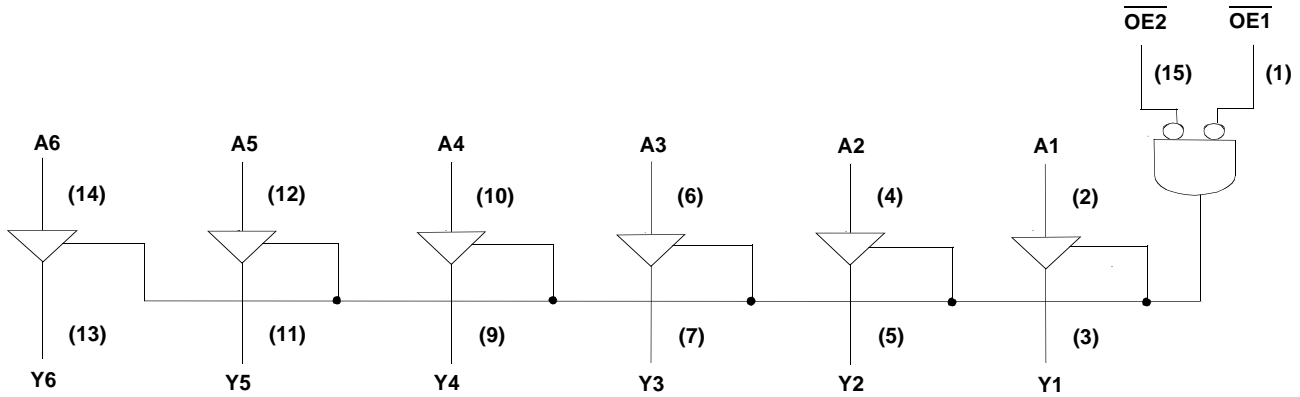

RADIATION HARDNESS SPECIFICATIONS ¹

PARAMETER	LIMIT	UNITS
Total Dose	1.0E6	rads(Si)
SEU Threshold ²	80	MeV-cm ² /mg
SEL Threshold	120	MeV-cm ² /mg
Neutron Fluence	1.0E14	n/cm ²

Notes:

1. Logic will not latchup during radiation exposure within the limits defined in the table.
2. Device storage elements are immune to SEU affects.

ABSOLUTE MAXIMUM RATINGS

SYMBOL	PARAMETER	LIMIT	UNITS
V _{DD}	Supply voltage	-0.3 to 7.0	V
V _{I/O}	Voltage any pin	-.3 to V _{DD} +.3	V
T _{STG}	Storage Temperature range	-65 to +150	°C
T _J	Maximum junction temperature	+175	°C
T _{LS}	Lead temperature (soldering 5 seconds)	+300	°C
Θ _{JC}	Thermal resistance junction to case	20	°C/W
I _I	DC input current	±10	mA
P _D	Maximum power dissipation	1	W

Note:

1. Stresses outside the listed absolute maximum ratings may cause permanent damage to the device. This is a stress rating only, functional operation of the device at these or any other conditions beyond limits indicated in the operational sections is not recommended. Exposure to absolute maximum rating conditions for extended periods may affect device reliability.

RECOMMENDED OPERATING CONDITIONS

SYMBOL	PARAMETER	LIMIT	UNITS
V_{DD}	Supply voltage	4.5 to 5.5	V
V_{IN}	Input voltage any pin	0 to V_{DD}	V
T_C	Temperature range	-55 to + 125	°C

DC ELECTRICAL CHARACTERISTICS ⁷ $(V_{DD} = 5.0V \pm 10\%; V_{SS} = 0V^6, -55^{\circ}C < T_C < +125^{\circ}C)$

SYMBOL	PARAMETER	CONDITION	MIN	MAX	UNIT
V_{IL}	Low-level input voltage ¹ ACTS ACS			0.8 .3 V_{DD}	V
V_{IH}	High-level input voltage ¹ ACTS ACS		.5 V_{DD} .7 V_{DD}		V
I_{IN}	Input leakage current ACTS/ACS	$V_{IN} = V_{DD}$ or V_{SS}	-1	1	μ A
V_{OL}	Low-level output voltage ³ ACTS ACS	$I_{OL} = 12.0mA$ $I_{OL} = 100\mu A$		0.40 0.25	V
V_{OH}	High-level output voltage ³ ACTS ACS	$I_{OH} = -12.0mA$ $I_{OH} = -100\mu A$.7 V_{DD} $V_{DD} - 0.25$		V
I_{OZ}	Three-state output leakage current	$V_O = V_{DD}$ and V_{SS}	-30	30	μ A
I_{OS}	Short-circuit output current ^{2,4} ACTS/ACS	$V_O = V_{DD}$ and V_{SS}	-300	300	mA
I_{OL}	Output current ¹⁰ (Sink)	$V_{IN} = V_{DD}$ or V_{SS} $V_{OL} = 0.4V$	12		mA
I_{OH}	Output current ¹⁰ (Source)	$V_{IN} = V_{DD}$ or V_{SS} $V_{OH} = V_{DD} - 0.4V$	-12		mA
P_{total}	Power dissipation ^{2, 8, 9}	$C_L = 50pF$		1.8	mW/ MHz
I_{DDQ}	Quiescent Supply Current	$V_{DD} = 5.5V$		10	μ A
ΔI_{DDQ}	Quiescent Supply Current Delta ACTS	For input under test $V_{IN} = V_{DD} - 2.1V$ For all other inputs $V_{IN} = V_{DD}$ or V_{SS} $V_{DD} = 5.5V$		1.6	mA
C_{IN}	Input capacitance ⁵	$f = 1MHz @ 0V$		15	pF
C_{OUT}	Output capacitance ⁵	$f = 1MHz @ 0V$		15	pF

UT54ACS365/UT54ACTS365

Notes:

1. Functional tests are conducted in accordance with MIL-STD-883 with the following input test conditions: $V_{IH} = V_{IH(min)} + 20\%$, $- 0\%$; $V_{IL} = V_{IL(max)} + 0\%$, $- 50\%$, as specified herein, for TTL, CMOS, or Schmitt compatible inputs. Devices may be tested using any input voltage within the above specified range, but are guaranteed to $V_{IH(min)}$ and $V_{IL(max)}$.
2. Supplied as a design limit but not guaranteed or tested.
3. Per MIL-PRF-38535, for current density $\leq 5.0E5$ amps/cm², the maximum product of load capacitance (per output buffer) times frequency should not exceed 3,765 pF/MHz.
4. Not more than one output may be shorted at a time for maximum duration of one second.
5. Capacitance measured for initial qualification and when design changes may affect the value. Capacitance is measured between the designated terminal and V_{SS} at frequency of 1MHz and a signal amplitude of 50mV rms maximum.
6. Maximum allowable relative shift equals 50mV.
7. All specifications valid for radiation dose $\leq 1E6$ rads(Si).
8. Power does not include power contribution of any TTL output sink current.
9. Power dissipation specified per switching output.
10. This value is guaranteed based on characterization data, but not tested.

AC ELECTRICAL CHARACTERISTICS ²(V_{DD} = 5.0V ±10%; V_{SS} = 0V ¹, -55 °C < T_C < +125°C)

SYMBOL	PARAMETER	MINIMUM	MAXIMUM	UNIT
t _{PLH}	Data to output	2	11	ns
t _{PHL}	Data to output	2	13	ns
t _{PZL}	$\overline{\text{OE}}$ low to output active	2	14	ns
t _{PZH}	$\overline{\text{OE}}$ low to output active	2	15	ns
t _{PLZ}	$\overline{\text{OE}}$ high to output three-state	2	12	ns
t _{PHZ}	$\overline{\text{OE}}$ high to output three-state	2	14	ns

Notes:

1. Maximum allowable relative shift equals 50mV.
2. All specifications valid for radiation dose ≤ 1E6 rads(Si).

UT54ACS373/UT54ACTS373

Radiation-Hardened Octal Transparent Latches with Three-State Outputs

FEATURES

- 8 latches in a single package
- Three-state bus-driving true outputs
- Full parallel access for loading
- 1.2μ radiation-hardened CMOS
 - Latchup immune
- High speed
- Low power consumption
- Single 5 volt supply
- Available QML Q or V processes
- Flexible package
 - 20-pin DIP
 - 20-lead flatpack

DESCRIPTION

The UT54ACS373 and the UT54ACTS373 are 8-bit latches with three-state outputs designed for driving highly capacitive or relatively low-impedance loads. The device is suitable for buffer registers, I/O ports, and bidirectional bus drivers.

The eight latches are transparent D latches. While the enable (C) is high the Q outputs will follow the data (D) inputs. When the enable is taken low, the Q outputs will be latched at the levels that were set up at the D inputs.

An output-control input (\overline{OC}) places the eight outputs in either a normal logic state (high or low logic levels) or a high-impedance state. The high-impedance third state and increased drive provide the capability to drive the bus line in a bus-organized system without need for interface or pull-up components.

The output control \overline{OC} does not affect the internal operations of the latches. Old data can be retained or new data can be entered while the outputs are off.

The devices are characterized over full military temperature range of -55°C to +125°C.

FUNCTION TABLE

INPUTS			OUTPUT
\overline{OC}	C	nD	nQ
L	H	H	H
L	H	L	L
L	L	X	nQ ₀
H	X	X	Z ¹

Note:

1. Data may be latched internally.

PINOUTS

20-Pin DIP Top View

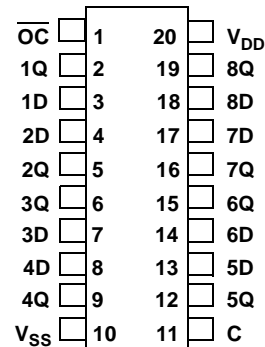

20-Lead Flatpack Top View

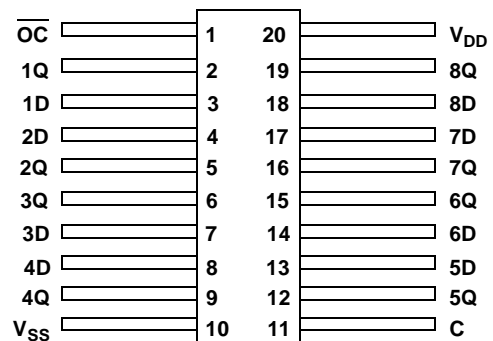

LOGIC SYMBOL

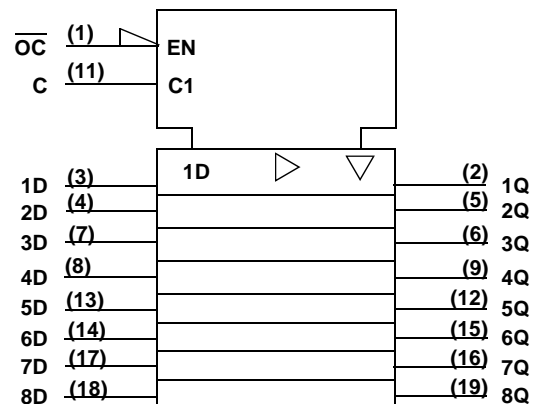

Note:

1. Logic symbol in accordance with ANSI/IEEE Std 91-1984 and IEC Publication 617-12.

LOGIC DIAGRAM

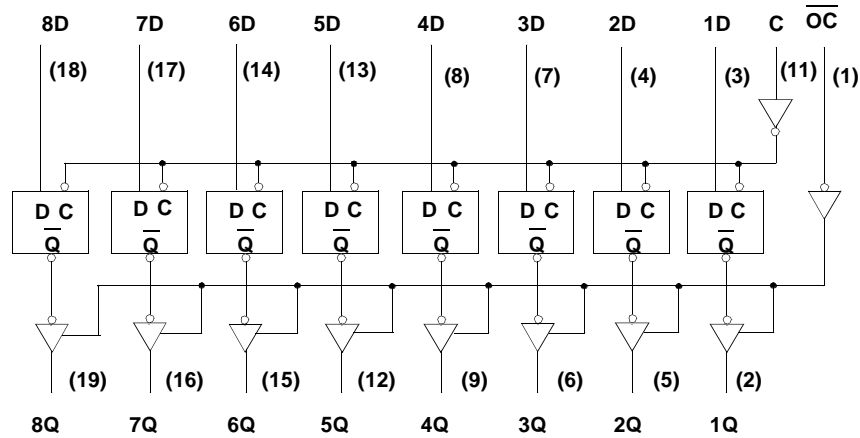

RADIATION HARDNESS SPECIFICATIONS ¹

PARAMETER	LIMIT	UNITS
Total Dose	1.0E6	rads(Si)
SEU Threshold ²	80	MeV-cm ² /mg
SEL Threshold	120	MeV-cm ² /mg
Neutron Fluence	1.0E14	n/cm ²

Notes:

1. Logic will not latchup during radiation exposure within the limits defined in the table.
2. Device storage elements are immune to SEU affects.

ABSOLUTE MAXIMUM RATING

SYMBOL	PARAMETER	LIMIT	UNITS
V _{DD}	Supply voltage	-0.3 to 7.0	V
V _{IO}	Voltage any pin	-.3 to V _{DD} +.3	V
T _{STG}	Storage Temperature range	-65 to +150	°C
T _J	Maximum junction temperature	+175	°C
T _{LS}	Lead temperature (soldering 5 seconds)	+300	°C
Θ _{JC}	Thermal resistance junction to case	20	°C/W
I _I	DC input current	±10	mA
P _D	Maximum power dissipation	1	W

Note:

1. Stresses outside the listed absolute maximum ratings may cause permanent damage to the device. This is a stress rating only, functional operation of the device at these or any other conditions beyond limits indicated in the operational sections is not recommended. Exposure to absolute maximum rating conditions for extended periods may affect device reliability.

RECOMMENDED OPERATING CONDITIONS

SYMBOL	PARAMETER	LIMIT	UNITS
V_{DD}	Supply voltage	4.5 to 5.5	V
V_{IN}	Input voltage any pin	0 to V_{DD}	V
T_C	Temperature range	-55 to + 125	°C

DC ELECTRICAL CHARACTERISTICS ⁷(V_{DD} = 5.0V ±10%; V_{SS} = 0V ⁶, -55 °C < T_C < +125°C)

SYMBOL	PARAMETER	CONDITION	MIN	MAX	UNIT
V _{IL}	Low-level input voltage ¹ ACTS ACS			0.8 .3V _{DD}	V
V _{IH}	High-level input voltage ¹ ACTS ACS		.5V _{DD} .7V _{DD}		V
I _{IN}	Input leakage current ACTS/ACS	V _{IN} = V _{DD} or V _{SS}	-1	1	μA
V _{OL}	Low-level output voltage ³ ACTS ACS	I _{OL} = 8.0mA I _{OL} = 100μA		0.40 0.25	V
V _{OH}	High-level output voltage ³ ACTS ACS	I _{OH} = -8.0mA I _{OH} = -100μA	.7V _{DD} V _{DD} - 0.25		V
I _{OZ}	Three-state output leakage current	V _O = V _{DD} and V _{SS}	-20	20	μA
I _{OS}	Short-circuit output current ^{2,4} ACTS/ACS	V _O = V _{DD} and V _{SS}	-200	200	mA
I _{OL}	Output current ¹⁰ (Sink)	V _{IN} = V _{DD} or V _{SS} V _{OL} = 0.4V	8		mA
I _{OH}	Output current ¹⁰ (Source)	V _{IN} = V _{DD} or V _{SS} V _{OH} = V _{DD} - 0.4V	-8		mA
P _{total}	Power dissipation ^{2, 8, 9}	C _L = 50pF		1.9	mW/ MHz
I _{DDQ}	Quiescent Supply Current	V _{DD} = 5.5V		10	μA
ΔI _{DDQ}	Quiescent Supply Current Delta ACTS	For input under test V _{IN} = V _{DD} - 2.1V For all other inputs V _{IN} = V _{DD} or V _{SS} V _{DD} = 5.5V		1.6	mA
C _{IN}	Input capacitance ⁵	f = 1MHz @ 0V		15	pF
C _{OUT}	Output capacitance ⁵	f = 1MHz @ 0V		15	pF

UT54ACS373/UT54ACTS373

Notes:

1. Functional tests are conducted in accordance with MIL-STD-883 with the following input test conditions: $V_{IH} = V_{IH(min)} + 20\%$, $- 0\%$; $V_{IL} = V_{IL(max)} + 0\%$, $- 50\%$, as specified herein, for TTL, CMOS, or Schmitt compatible inputs. Devices may be tested using any input voltage within the above specified range, but are guaranteed to $V_{IH(min)}$ and $V_{IL(max)}$.
2. Supplied as a design limit but not guaranteed or tested.
3. Per MIL-PRF-38535, for current density $\leq 5.0E5$ amps/cm², the maximum product of load capacitance (per output buffer) times frequency should not exceed 3,765 pF/MHz.
4. Not more than one output may be shorted at a time for maximum duration of one second.
5. Capacitance measured for initial qualification and when design changes may affect the value. Capacitance is measured between the designated terminal and V_{SS} at frequency of 1MHz and a signal amplitude of 50mV rms maximum.
6. Maximum allowable relative shift equals 50mV.
7. All specifications valid for radiation dose $\leq 1E6$ rads(Si).
8. Power does not include power contribution of any TTL output sink current.
9. Power dissipation specified per switching output.
10. This value is guaranteed based on characterization data, but not tested.

AC ELECTRICAL CHARACTERISTICS ²(V_{DD} = 5.0V ±10%; V_{SS} = 0V ¹, -55 °C < T_C < +125°C)

SYMBOL	PARAMETER	MINIMUM	MAXIMUM	UNIT
t _{PLH}	Data to Qn	1	14	ns
t _{PHL}	Data to Qn	1	16	ns
t _{PLH}	C ↑ to Qn	1	16	ns
t _{PHL}	C ↑ to Qn	1	18	ns
t _{PZL}	\overline{OC} low to Qn	1	14	ns
t _{PZH}	\overline{OC} low to Qn	1	14	ns
t _{PLZ}	\overline{OC} high to Qn three-state	1	14	ns
t _{PHZ}	\overline{OC} high to Qn three-state	1	14	ns
f _{MAX}	Maximum clock frequency		71	MHz
t _{SU}	Data setup time before C ↓	5		ns
t _H	Data hold time after C ↓	4		ns
t _w	Minimum pulse width C high	7		ns

Notes:

1. Maximum allowable relative shift equals 50mV.
2. All specifications valid for radiation dose ≤ 1E6 rads(Si).

UT54ACS374/UT54ACTS374

Radiation-Hardened Octal D-Type Flip-Flops with Three-State Outputs

FEATURES

- 8 latches in a single package
- Three-state bus-driving true outputs
- Full parallel access for loading
- 1.2μ radiation-hardened CMOS
 - Latchup immune
- High speed
- Low power consumption
- Single 5 volt supply
- Available QML Q or V processes
- Flexible package
 - 20-pin DIP
 - 20-lead flatpack

DESCRIPTION

The UT54ACS374 and the UT54ACTS374 are non-inverting octal D type flip-flops with three-state outputs designed for driving highly capacitive or relatively low-impedance loads. The device is suitable for buffer registers, I/O ports, and bidirectional bus drivers.

The eight flip-flops are edge triggered D-type flip-flops. On the positive transition of the clock the Q outputs will follow the data (D) inputs.

An output-control input (\overline{OC}) places the eight outputs in either a normal logic state (high or low logic level) or a high-impedance state. The high-impedance third state and increased drive provide the capability to drive the bus line in a bus-organized system without the need for interface or pull-up components.

The output control \overline{OC} does not affect the internal operations of the flip-flops. Old data can be retained or new data can be entered while the outputs are off.

The devices are characterized over full military temperature range of -55°C to +125°C.

FUNCTION TABLE

INPUTS			OUTPUT
\overline{OC}	CLK	nD	nQ
L	↑	H	H
L	↑	L	L
L	L	X	nQ ₀
H	X	X	Z

PINOUTS

20-Pin DIP Top View

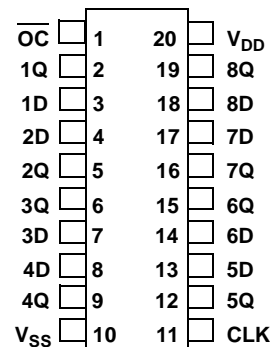

20-Lead Flatpack Top View

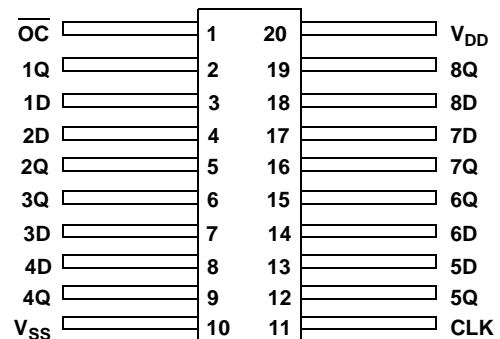

LOGIC SYMBOL

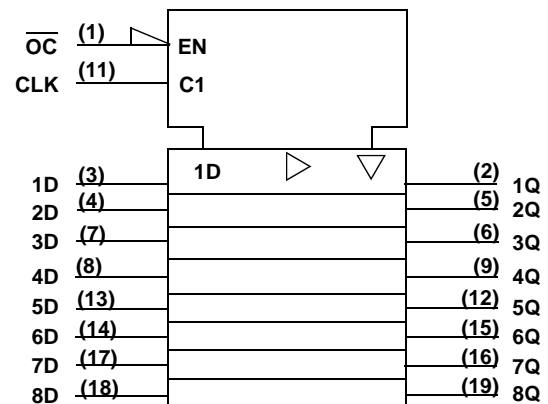

Note:

1. Logic symbol in accordance with ANSI/IEEE Std 91-1984 and IEC Publication 617-12.

LOGIC DIAGRAM

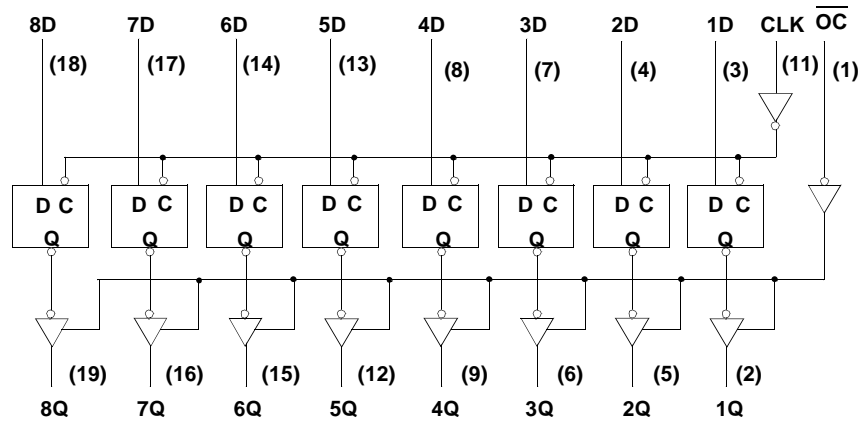

RADIATION HARDNESS SPECIFICATIONS ¹

PARAMETER	LIMIT	UNITS
Total Dose	1.0E6	rads(Si)
SEU Threshold ²	80	MeV-cm ² /mg
SEL Threshold	120	MeV-cm ² /mg
Neutron Fluence	1.0E14	n/cm ²

Notes:

1. Logic will not latchup during radiation exposure within the limits defined in the table.
2. Device storage elements are immune to SEU affects.

ABSOLUTE MAXIMUM RATING

SYMBOL	PARAMETER	LIMIT	UNITS
V _{DD}	Supply voltage	-0.3 to 7.0	V
V _{IO}	Voltage any pin	-.3 to V _{DD} +.3	V
T _{STG}	Storage Temperature range	-65 to +150	°C
T _J	Maximum junction temperature	+175	°C
T _{LS}	Lead temperature (soldering 5 seconds)	+300	°C
Θ _{JC}	Thermal resistance junction to case	20	°C/W
I _I	DC input current	±10	mA
P _D	Maximum power dissipation	1	W

Note:

1. Stresses outside the listed absolute maximum ratings may cause permanent damage to the device. This is a stress rating only, functional operation of the device at these or any other conditions beyond limits indicated in the operational sections is not recommended. Exposure to absolute maximum rating conditions for extended periods may affect device reliability.

RECOMMENDED OPERATING CONDITIONS

SYMBOL	PARAMETER	LIMIT	UNITS
V_{DD}	Supply voltage	4.5 to 5.5	V
V_{IN}	Input voltage any pin	0 to V_{DD}	V
T_C	Temperature range	-55 to + 125	°C

DC ELECTRICAL CHARACTERISTICS⁷(V_{DD} = 5.0V ±10%; V_{SS} = 0V⁶, -55 °C < T_C < +125°C)

SYMBOL	PARAMETER	CONDITION	MIN	MAX	UNIT
V _{IL}	Low-level input voltage ¹ ACTS ACS			0.8 .3V _{DD}	V
V _{IH}	High-level input voltage ¹ ACTS ACS		.5V _{DD} .7V _{DD}		V
I _{IN}	Input leakage current ACTS/ACS	V _{IN} = V _{DD} or V _{SS}	-1	1	μA
V _{OL}	Low-level output voltage ³ ACTS ACS	I _{OL} = 8.0mA I _{OL} = 100μA		0.40 0.25	V
V _{OH}	High-level output voltage ³ ACTS ACS	I _{OH} = -8.0mA I _{OH} = -100μA	.7V _{DD} V _{DD} - 0.25		V
I _{OZ}	Three-state output leakage current	V _O = V _{DD} and V _{SS}	-20	20	μA
I _{OS}	Short-circuit output current ^{2,4} ACTS/ACS	V _O = V _{DD} and V _{SS}	-200	200	mA
I _{OL}	Output current ¹⁰ (Sink)	V _{IN} = V _{DD} or V _{SS} V _{OL} = 0.4V	8		mA
I _{OH}	Output current ¹⁰ (Source)	V _{IN} = V _{DD} or V _{SS} V _{OH} = V _{DD} - 0.4V	-8		mA
P _{total}	Power dissipation ^{2,8,9}	C _L = 50pF		1.9	mW/ MHz
I _{DDQ}	Quiescent Supply Current	V _{DD} = 5.5V		10	μA
ΔI _{DDQ}	Quiescent Supply Current Delta ACTS	For input under test V _{IN} = V _{DD} - 2.1V For all other inputs V _{IN} = V _{DD} or V _{SS} V _{DD} = 5.5V		1.6	mA
C _{IN}	Input capacitance ⁵	f = 1MHz @ 0V		15	pF
C _{OUT}	Output capacitance ⁵	f = 1MHz @ 0V		15	pF

UT54ACS374/UT54ACTS374

Notes:

1. Functional tests are conducted in accordance with MIL-STD-883 with the following input test conditions: $V_{IH} = V_{IH(min)} + 20\%$, $- 0\%$; $V_{IL} = V_{IL(max)} + 0\%$, $- 50\%$, as specified herein, for TTL, CMOS, or Schmitt compatible inputs. Devices may be tested using any input voltage within the above specified range, but are guaranteed to $V_{IH(min)}$ and $V_{IL(max)}$.
2. Supplied as a design limit but not guaranteed or tested.
3. Per MIL-PRF-38535, for current density $\leq 5.0E5$ amps/cm², the maximum product of load capacitance (per output buffer) times frequency should not exceed 3,765 pF/MHz.
4. Not more than one output may be shorted at a time for maximum duration of one second.
5. Capacitance measured for initial qualification and when design changes may affect the value. Capacitance is measured between the designated terminal and V_{SS} at frequency of 1MHz and a signal amplitude of 50mV rms maximum.
6. Maximum allowable relative shift equals 50mV.
7. All specifications valid for radiation dose $\leq 1E6$ rads(Si).
8. Power does not include power contribution of any TTL output sink current.
9. Power dissipation specified per switching output.
10. This value is guaranteed based on characterization data, but not tested.

AC ELECTRICAL CHARACTERISTICS ²(V_{DD} = 5.0V ±10%; V_{SS} = 0V ¹, -55 °C < T_C < +125°C)

SYMBOL	PARAMETER	MINIMUM	MAXIMUM	UNIT
t _{PLH}	CLK to Qn	1	15	ns
t _{PHL}	CLK to Qn	1	18	ns
t _{PZL}	\overline{OC} low to Qn active	1	13	ns
t _{PZH}	\overline{OC} low to Qn active	1	13	ns
t _{PLZ}	\overline{OC} high to Qn three-state	1	11	ns
t _{PHZ}	\overline{OC} high to Qn three-state	1	12	ns
f _{MAX}	Maximum clock frequency		71	MHz
t _{SU}	Data setup time before CLK ↑	5		ns
t _H	Data hold time after CLK ↑	2		ns
t _W	Minimum pulse width CLK high, CLK low	7		ns

Notes:

1. Maximum allowable relative shift equals 50mV.
2. All specifications valid for radiation dose ≤ 1E6 rads(Si).

UT54ACS540/UT54ACTS540

Radiation-Hardened

Octal Buffers & Line Drivers, Inverted Three-State Outputs

FEATURES

- Three-state outputs drive bus lines or buffer memory address registers
- 1.2μ radiation-hardened CMOS
 - Latchup immune
- High speed
- Low power consumption
- Single 5 volt supply
- Available QML Q or V processes
- Flexible package
 - 20-pin DIP
 - 20-lead flatpack

DESCRIPTION

The UT54ACS540 and the UT54ACTS540 are inverting octal buffers and line drivers which improve the performance and density of three-state memory address drivers, clock drivers, and bus-oriented receivers and transmitters.

The devices are characterized over full military temperature range of -55°C to +125°C.

FUNCTION TABLE

INPUTS		An	OUTPUT Yn
$\overline{1G}$	$\overline{2G}$		
L	L	L	H
L	L	H	L
H	X	X	Z
X	H	X	Z

LOGIC SYMBOL

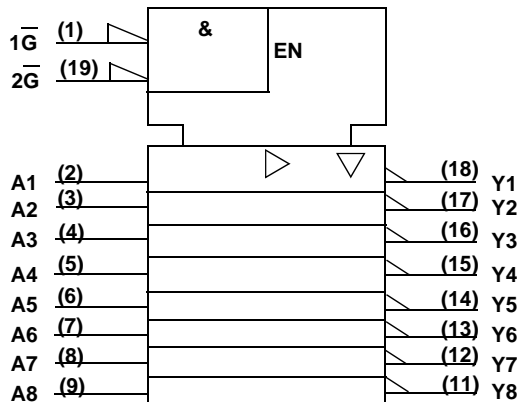

Note:

1. Logic symbol in accordance with ANSI/IEEE Std 91-1984 and IEC Publication 617-12.

PINOUTS

20-Pin DIP Top View

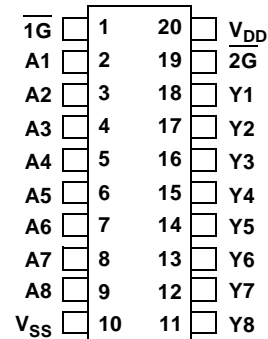

20-Lead Flatpack Top View

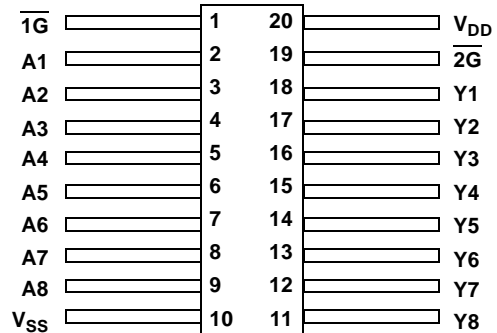

LOGIC DIAGRAM

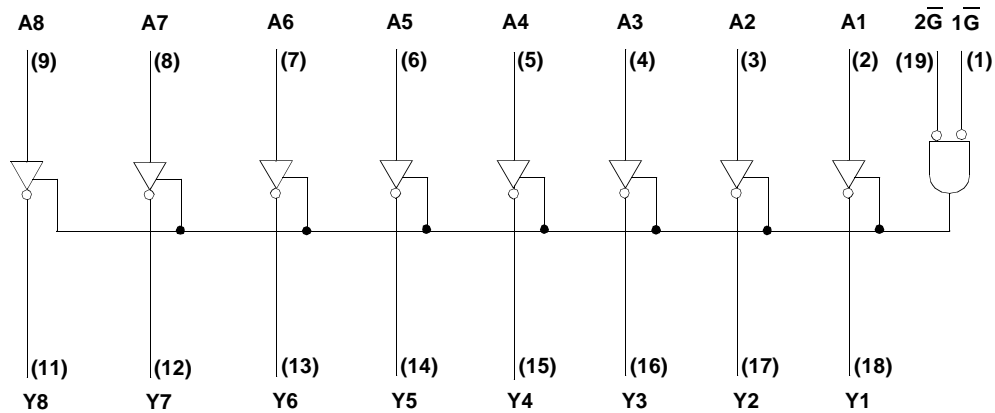

RADIATION HARDNESS SPECIFICATIONS ¹

PARAMETER	LIMIT	UNITS
Total Dose	1.0E6	rads(Si)
SEU Threshold ²	80	MeV-cm ² /mg
SEL Threshold	120	MeV-cm ² /mg
Neutron Fluence	1.0E14	n/cm ²

Notes:

- 1. Logic will not latchup during radiation exposure within the limits defined in the table
- 2. Device storage elements are immune to SEU affects.

ABSOLUTE MAXIMUM RATINGS

SYMBOL	PARAMETER	LIMIT	UNITS
V _{DD}	Supply voltage	-0.3 to 7.0	V
V _{I/O}	Voltage any pin	-.3 to V _{DD} +.3	V
T _{STG}	Storage Temperature range	-65 to +150	°C
T _J	Maximum junction temperature	+175	°C
T _{LS}	Lead temperature (soldering 5 seconds)	+300	°C
Θ _{JC}	Thermal resistance junction to case	20	°C/W
I _I	DC input current	±10	mA
P _D	Maximum power dissipation	1	W

Note:

- 1. Stresses outside the listed absolute maximum ratings may cause permanent damage to the device. This is a stress rating only, functional operation of the device at these or any other conditions beyond limits indicated in the operational sections is not recommended. Exposure to absolute maximum rating conditions for extended periods may affect device reliability.

RECOMMENDED OPERATING CONDITIONS

SYMBOL	PARAMETER	LIMIT	UNITS
V_{DD}	Supply voltage	4.5 to 5.5	V
V_{IN}	Input voltage any pin	0 to V_{DD}	V
T_C	Temperature range	-55 to + 125	°C

DC ELECTRICAL CHARACTERISTICS ⁷(V_{DD} = 5.0V ±10%; V_{SS} = 0V ⁶, -55 °C < T_C < +125°C)

SYMBOL	PARAMETER	CONDITION	MIN	MAX	UNIT
V _{IL}	Low-level input voltage ¹ ACTS ACS			0.8 .3V _{DD}	V
V _{IH}	High-level input voltage ¹ ACTS ACS		.5V _{DD} .7V _{DD}		V
I _{IN}	Input leakage current ACTS/ACS	V _{IN} = V _{DD} or V _{SS}	-1	1	μA
V _{OL}	Low-level output voltage ³ ACTS ACS	I _{OL} = 12.0mA I _{OL} = 100μA		0.40 0.25	V
V _{OH}	High-level output voltage ³ ACTS ACS	I _{OH} = -12.0mA I _{OH} = -100μA	.7V _{DD} V _{DD} - 0.25		V
I _{OZ}	Three-state output leakage current	V _O = V _{DD} and V _{SS}	-30	30	μA
I _{OS}	Short-circuit output current ^{2,4} ACTS/ACS	V _O = V _{DD} and V _{SS}	-300	300	mA
I _{OL}	Output current ¹⁰ (Sink)	V _{IN} = V _{DD} or V _{SS} V _{OL} = 0.4V	12		mA
I _{OH}	Output current ¹⁰ (Source)	V _{IN} = V _{DD} or V _{SS} V _{OH} = V _{DD} - 0.4V	-12		mA
P _{total}	Power dissipation ^{2, 8, 9}	C _L = 50pF		2.1	mW/ MHz
I _{DDQ}	Quiescent Supply Current	V _{DD} = 5.5V		10	μA
ΔI _{DDQ}	Quiescent Supply Current Delta ACTS	For input under test V _{IN} = V _{DD} - 2.1V For all other inputs V _{IN} = V _{DD} or V _{SS} V _{DD} = 5.5V		1.6	mA
C _{IN}	Input capacitance ⁵	f = 1MHz @ 0V		15	pF
C _{OUT}	Output capacitance ⁵	f = 1MHz @ 0V		15	pF

UT54ACS540/UT54ACTS540

Notes:

1. Functional tests are conducted in accordance with MIL-STD-883 with the following input test conditions: $V_{IH} = V_{IH(min)} + 20\%$, $- 0\%$; $V_{IL} = V_{IL(max)} + 0\%$, $- 50\%$, as specified herein, for TTL, CMOS, or Schmitt compatible inputs. Devices may be tested using any input voltage within the above specified range, but are guaranteed to $V_{IH(min)}$ and $V_{IL(max)}$.
2. Supplied as a design limit but not guaranteed or tested.
3. Per MIL-PRF-38535, for current density $\leq 5.0E5$ amps/cm², the maximum product of load capacitance (per output buffer) times frequency should not exceed 3,765 pF/MHz.
4. Not more than one output may be shorted at a time for maximum duration of one second.
5. Capacitance measured for initial qualification and when design changes may affect the value. Capacitance is measured between the designated terminal and V_{SS} at frequency of 1MHz and a signal amplitude of 50mV rms maximum.
6. Maximum allowable relative shift equals 50mV.
7. All specifications valid for radiation dose $\leq 1E6$ rads(Si).
8. Power does not include power contribution of any TTL output sink current.
9. Power dissipation specified per switching output.
10. This value is guaranteed based on characterization data, but not tested.

AC ELECTRICAL CHARACTERISTICS ²(V_{DD} = 5.0V ±10%; V_{SS} = 0V ¹, -55 °C < T_C < +125°C)

SYMBOL	PARAMETER	MINIMUM	MAXIMUM	UNIT
t _{PLH}	An to Yn	1	12	ns
t _{PHL}	An to Yn	1	13	ns
t _{PZL}	\overline{G} low to Yn active	2	14	ns
t _{PZH}	\overline{G} low to Yn active	2	15	ns
t _{PLZ}	\overline{G} high to Yn three-state	2	13	ns
t _{PHZ}	\overline{G} high to Yn three-state	2	14	ns

Notes:

1. Maximum allowable relative shift equals 50mV.
2. All specifications valid for radiation dose ≤ 1E6 rads(Si).

UT54ACS541/UT54ACTS541

Radiation-Hardened

Octal Buffers & Line Drivers, Three-State Outputs

Dec. 1, 2003

FEATURES

- Three-state outputs drive bus lines or buffer memory address registers
- 1.2 μ radiation-hardened CMOS (ACS541) and 0.6 μ CRH CMOS process (ACTS541)
 - Latchup immune
- High speed
- Low power consumption
- Single 5 volt supply
- Available QML Q or V processes
- Flexible package
 - 20-pin DIP (not available for the ACTS541)
 - 20-lead flatpack

DESCRIPTION

The UT54ACS541 and the UT54ACTS541 are non-inverting octal buffers and line drivers which improve the performance and density of three-state memory address drivers, clock drivers, and bus-oriented receivers and transmitters. The devices are characterized over full military temperature range of -55°C to +125°C.

FUNCTION TABLE

INPUTS			OUTPUT
$\overline{1G}$	$\overline{2G}$	A _n	Y _n
L	L	L	L
L	L	H	H
H	X	X	Z
X	H	X	Z

LOGIC SYMBOL

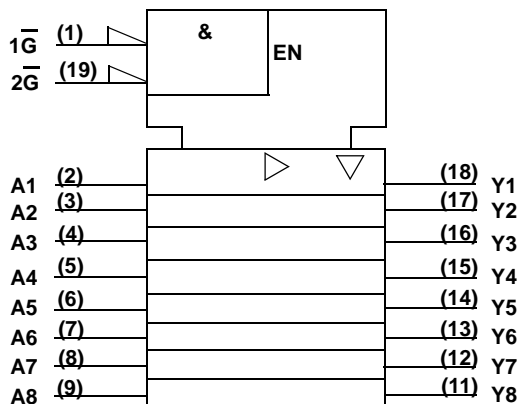

Note:

1. Logic symbol in accordance with ANSI/IEEE Std 91-1984 and IEC Publication 617-12.

PINOUPS

20-Pin DIP Top View

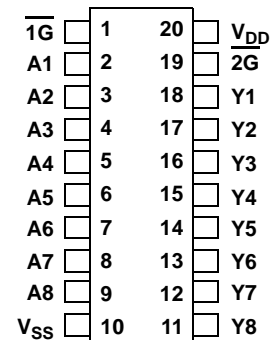

20-Lead Flatpack Top View

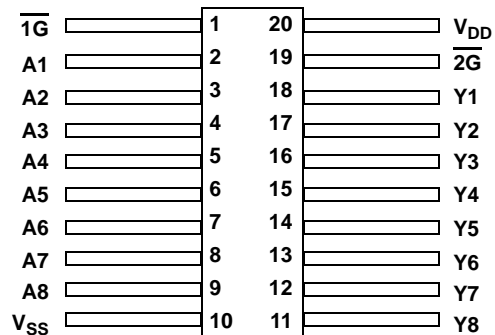

LOGIC DIAGRAM

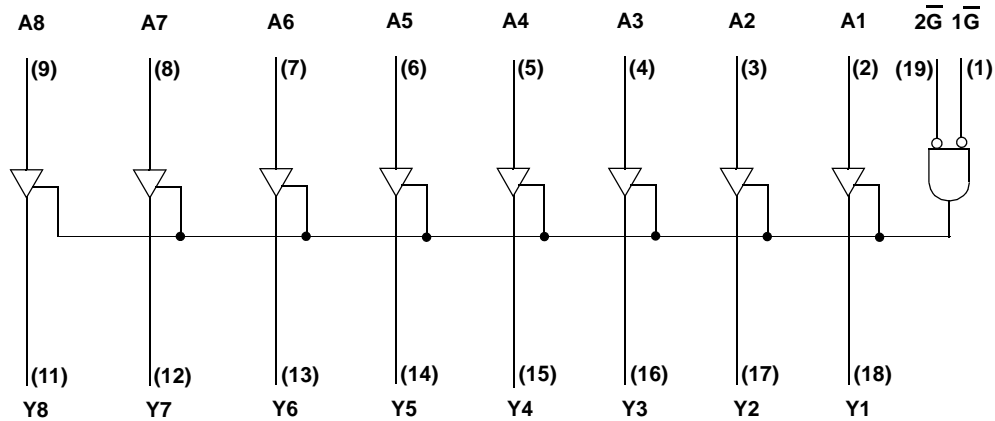

RADIATION HARDNESS SPECIFICATIONS ¹

PARAMETER	LIMIT	UNITS
Total Dose	1.0E6 (ACS541) 5.0E5 (ACTS541)	rads(Si)
SEU Threshold ²	80	MeV-cm ² /mg
SEL Threshold	120	MeV-cm ² /mg
Neutron Fluence	1.0E14	n/cm ²

Notes:

- 1. Logic will not latchup during radiation exposure within the limits defined in the table
- 2. Device storage elements are immune to SEU affects.

ABSOLUTE MAXIMUM RATINGS

SYMBOL	PARAMETER	LIMIT	UNITS
V _{DD}	Supply voltage	-0.3 to 7.0	V
V _{I/O}	Voltage any pin	-.3 to V _{DD} +.3	V
T _{STG}	Storage Temperature range	-65 to +150	°C
T _J	Maximum junction temperature	+175	°C
T _{LS}	Lead temperature (soldering 5 seconds)	+300	°C
Θ _{JC}	Thermal resistance junction to case	20	°C/W
I _I	DC input current	±10	mA
P _D	Maximum power dissipation	1	W

Note:

- 1. Stresses outside the listed absolute maximum ratings may cause permanent damage to the device. This is a stress rating only, functional operation of the device at these or any other conditions beyond limits indicated in the operational sections is not recommended. Exposure to absolute maximum rating conditions for extended periods may affect device reliability.

RECOMMENDED OPERATING CONDITIONS

SYMBOL	PARAMETER	LIMIT	UNITS
V_{DD}	Supply voltage	4.5 to 5.5	V
V_{IN}	Input voltage any pin	0 to V_{DD}	V
T_C	Temperature range	-55 to + 125	°C

DC ELECTRICAL CHARACTERISTICS ⁷(V_{DD} = 5.0V ±10%; V_{SS} = 0V ⁶, -55°C < T_C < +125°C)

SYMBOL	PARAMETER	CONDITION	MIN	MAX	UNIT
V _{IL}	Low-level input voltage ¹ ACTS ACS			0.8 .3V _{DD}	V
V _{IH}	High-level input voltage ¹ ACTS ACS		.5V _{DD} .7V _{DD}		V
I _{IN}	Input leakage current ACTS/ACS	V _{IN} = V _{DD} or V _{SS}	-1	1	μA
V _{OL}	Low-level output voltage ³ ACTS ACS	I _{OL} = 12.0mA I _{OL} = 100μA		0.40 0.25	V
V _{OH}	High-level output voltage ³ ACTS ACS	I _{OH} = -12.0mA I _{OH} = -100μA	.7V _{DD} V _{DD} - 0.25		V
I _{OZ}	Three-state output leakage current	V _O = V _{DD} and V _{SS}	-30	30	μA
I _{OS}	Short-circuit output current ^{2,4} ACTS/ACS	V _O = V _{DD} and V _{SS}	-300	300	mA
I _{OL}	Output current ¹⁰ (Sink)	V _{IN} = V _{DD} or V _{SS} V _{OL} = 0.4V	12		mA
I _{OH}	Output current ¹⁰ (Source)	V _{IN} = V _{DD} or V _{SS} V _{OH} = V _{DD} - 0.4V	-12		mA
P _{total}	Power dissipation ^{2, 8, 9}	C _L = 50pF		2.1	mW/ MHz
I _{DDQ}	Quiescent Supply Current	V _{DD} = 5.5V		10	μA
ΔI _{DDQ}	Quiescent Supply Current Delta ACTS	For input under test V _{IN} = V _{DD} - 2.1V For all other inputs V _{IN} = V _{DD} or V _{SS} V _{DD} = 5.5V		1.6	mA
C _{IN}	Input capacitance ⁵	f = 1MHz @ 0V		15	pF
C _{OUT}	Output capacitance ⁵	f = 1MHz @ 0V		15	pF

UT54ACS541/UT54ACTS541

Notes:

1. Functional tests are conducted in accordance with MIL-STD-883 with the following input test conditions: $V_{IH} = V_{IH(min)} + 20\%$, $- 0\%$; $V_{IL} = V_{IL(max)} + 0\%$, $- 50\%$, as specified herein, for TTL, CMOS, or Schmitt compatible inputs. Devices may be tested using any input voltage within the above specified range, but are guaranteed to $V_{IH(min)}$ and $V_{IL(max)}$.
2. Supplied as a design limit but not guaranteed or tested.
3. Per MIL-PRF-38535, for current density $\leq 5.0E5$ amps/cm², the maximum product of load capacitance (per output buffer) times frequency should not exceed 3,765 pF/MHz.
4. Not more than one output may be shorted at a time for maximum duration of one second.
5. Capacitance measured for initial qualification and when design changes may affect the value. Capacitance is measured between the designated terminal and V_{SS} at frequency of 1MHz and a signal amplitude of 50mV rms maximum.
6. Maximum allowable relative shift equals 50mV.
7. All ACS specifications are valid for radiation dose $\leq 1E6$ rads(Si), and all ACTS specifications are valid for radiation dose $\leq 5E5$ rads(Si).
8. Power does not include power contribution of any TTL output sink current.
9. Power dissipation specified per switching output.
10. This value is guaranteed based on characterization data, but not tested.

AC ELECTRICAL CHARACTERISTICS ²(V_{DD} = 5.0V ±10%; V_{SS} = 0V ¹, -55°C < T_C < +125°C)

SYMBOL	PARAMETER	MINIMUM	MAXIMUM	UNIT
t _{PLH}	An to Yn	1	11	ns
t _{PHL}	An to Yn	1	14	ns
t _{PZL}	\overline{G} low to Yn active	2	14	ns
t _{PZH}	\overline{G} low to Yn active	2	15	ns
t _{PLZ}	\overline{G} high to Yn three-state	2	12	ns
t _{PHZ}	\overline{G} high to Yn three-state	2	13	ns

Notes:

1. Maximum allowable relative shift equals 50mV.

2. For the ACTS version, all specifications are valid for radiation dose ≤1E6 rads(Si). For the ACTS version, all specifications are valid for radiation dose ≤5E5 rads(Si).

UT54ACS4002/UT54ACTS4002

Radiation-Hardened Dual 4-Input NOR Gates

FEATURES

- 1.2μ radiation-hardened CMOS
 - Latchup immune
- High speed
- Low power consumption
- Single 5 volt supply
- Available QML Q or V processes
- Flexible package
 - 14-pin DIP
 - 14-lead flatpack

DESCRIPTION

The UT54ACS4002 and the UT54ACTS4002 are dual 4-input NOR gates. A high on any input forces the output to a low state. The circuits perform the Boolean functions:

$$Y = \overline{A + B + C + D} = \overline{A} \cdot \overline{B} \cdot \overline{C} \cdot \overline{D}$$

The devices are characterized over full military temperature range of -55°C to +125°C.

FUNCTION TABLE

INPUTS				OUTPUT
A _n	B _n	C _n	D _n	Y _n
L	L	L	L	H
H	X	X	X	L
X	H	X	X	L
X	X	H	X	L
X	X	X	H	L

LOGIC SYMBOL

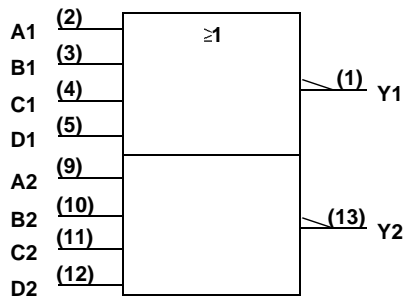

Note:

1. Logic symbol in accordance with ANSI/IEEE standard 91-1984 and IEC Publication 617-12.

PINOUTS

14-Pin DIP Top View

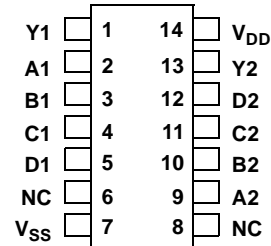

14-Lead Flatpack Top View

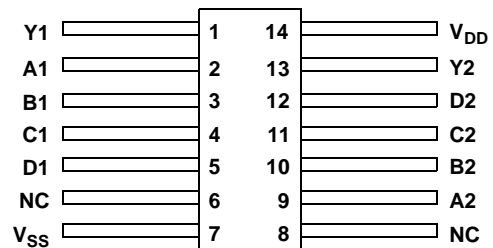

LOGIC DIAGRAM

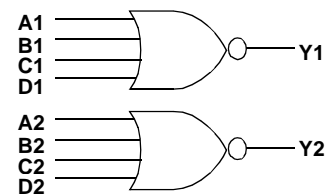

RADIATION HARDNESS SPECIFICATIONS ¹

PARAMETER	LIMIT	UNITS
Total Dose	1.0E6	rads(Si)
SEU Threshold ²	80	MeV-cm ² /mg
SEL Threshold	120	MeV-cm ² /mg
Neutron Fluence	1.0E14	n/cm ²

Notes:

- Logic will not latchup during radiation exposure within the limits defined in the table.
- Device storage elements are immune to SEU affects.

ABSOLUTE MAXIMUM RATINGS

SYMBOL	PARAMETER	LIMIT	UNITS
V _{DD}	Supply voltage	-0.3 to 7.0	V
V _{I/O}	Voltage any pin	-.3 to V _{DD} +.3	V
T _{STG}	Storage Temperature range	-65 to +150	°C
T _J	Maximum junction temperature	+175	°C
T _{LS}	Lead temperature (soldering 5 seconds)	+300	°C
Θ _{JC}	Thermal resistance junction to case	20	°C/W
I _I	DC input current	±10	mA
P _D	Maximum power dissipation	1	W

Note:

- Stresses outside the listed absolute maximum ratings may cause permanent damage to the device. This is a stress rating only, functional operation of the device at these or any other conditions beyond limits indicated in the operational sections is not recommended. Exposure to absolute maximum rating conditions for extended periods may affect device reliability.

RECOMMENDED OPERATING CONDITIONS

SYMBOL	PARAMETER	LIMIT	UNITS
V _{DD}	Supply voltage	4.5 to 5.5	V
V _{IN}	Input voltage any pin	0 to V _{DD}	V
T _C	Temperature range	-55 to + 125	°C

DC ELECTRICAL CHARACTERISTICS ⁷

($V_{DD} = 5.0V \pm 10\%$; $V_{SS} = 0V$ ⁶, $-55^{\circ}C < T_C < +125^{\circ}C$)

SYMBOL	PARAMETER	CONDITION	MIN	MAX	UNIT
V_{IL}	Low-level input voltage ¹ ACTS ACS			0.8 .3 V_{DD}	V
V_{IH}	High-level input voltage ¹ ACTS ACS		.5 V_{DD} .7 V_{DD}		V
I_{IN}	Input leakage current ACTS/ACS	$V_{IN} = V_{DD}$ or V_{SS}	-1	1	μA
V_{OL}	Low-level output voltage ³ ACTS ACS	$I_{OL} = 8.0mA$ $I_{OL} = 100\mu A$		0.40 0.25	V
V_{OH}	High-level output voltage ³ ACTS ACS	$I_{OH} = -8.0mA$ $I_{OH} = -100\mu A$.7 V_{DD} $V_{DD} - 0.25$		V
I_{OS}	Short-circuit output current ^{2,4} ACTS/ACS	$V_O = V_{DD}$ and V_{SS}	-200	200	mA
I_{OL}	Output current ¹⁰ (Sink)	$V_{IN} = V_{DD}$ or V_{SS} $V_{OL} = 0.4V$	8		mA
I_{OH}	Output current ¹⁰ (Source)	$V_{IN} = V_{DD}$ or V_{SS} $V_{OH} = V_{DD} - 0.4V$	-8		mA
P_{total}	Power dissipation ^{2,8,9}	$C_L = 50pF$		1.9	mW/ MHz
I_{DDQ}	Quiescent Supply Current	$V_{DD} = 5.5V$		10	μA
ΔI_{DDQ}	Quiescent Supply Current Delta ACTS	For input under test $V_{IN} = V_{DD} - 2.1V$ For all other inputs $V_{IN} = V_{DD}$ or V_{SS} $V_{DD} = 5.5V$		1.6	mA
C_{IN}	Input capacitance ⁵	$f = 1MHz @ 0V$		15	pF
C_{OUT}	Output capacitance ⁵	$f = 1MHz @ 0V$		15	pF

Notes:

1. Functional tests are conducted in accordance with MIL-STD-883 with the following input test conditions: $V_{IH} = V_{IH(min)} + 20\%$, $- 0\%$; $V_{IL} = V_{IL(max)} + 0\%$, $- 50\%$, as specified herein, for TTL, CMOS, or Schmitt compatible inputs. Devices may be tested using any input voltage within the above specified range, but are guaranteed to $V_{IH(min)}$ and $V_{IL(max)}$.
2. Supplied as a design limit but not guaranteed or tested.
3. Per MIL-PRF-38535, for current density $\leq 5.0E5$ amps/cm², the maximum product of load capacitance (per output buffer) times frequency should not exceed 3,765 pF/MHz.
4. Not more than one output may be shorted at a time for maximum duration of one second.
5. Capacitance measured for initial qualification and when design changes may affect the value. Capacitance is measured between the designated terminal and V_{SS} at frequency of 1MHz and a signal amplitude of 50mV rms maximum.
6. Maximum allowable relative shift equals 50mV.
7. All specifications valid for radiation dose $\leq 1E6$ rads(Si).
8. Power does not include power contribution of any TTL output sink current.
9. Power dissipation specified per switching output.
10. This value is guaranteed based on characterization data, but not tested.

AC ELECTRICAL CHARACTERISTICS ²

($V_{DD} = 5.0V \pm 10\%$; $V_{SS} = 0V$ ¹, $-55^{\circ}C < T_C < +125^{\circ}C$)

SYMBOL	PARAMETER	MINIMUM	MAXIMUM	UNIT
t_{PHL}	Input to output	1	12	ns
t_{PLH}	Input to output	2	14	ns

Notes:

1. Maximum allowable relative shift equals 50mV.
2. All specifications valid for radiation dose $\leq 1E6$ rads(Si).

2.0 RADHARD MSI PACKAGES

Side-Brazed Packages

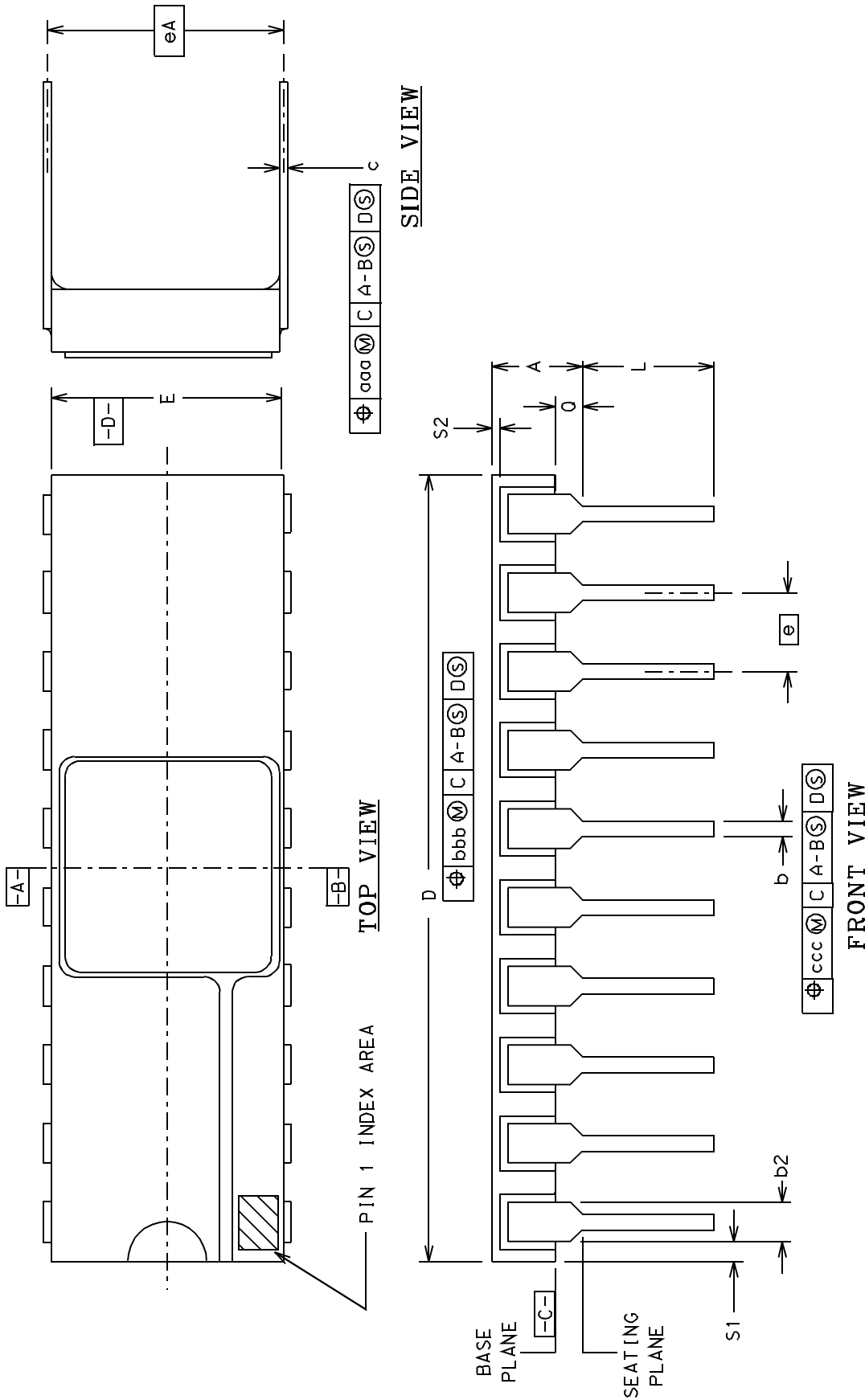

PKG CONFIG	LEAD COUNT	MIL-STD-1835 DWG CONF C	DIMENSION SYMBOLS														
			A	b	b2	c	D	E	e	eA	L	O	S1	S2	aaa	bbb	ccc
-01	14	D-1	0.200	0.026	0.065	0.018	0.785	0.310	0.100	0.300	0.200	0.060	-----	-----	0.015	0.030	0.010
			-----	0.014	0.045	0.008	-----	0.220	BSC	BSC	0.125	0.015	0.005	-----	-----	-----	
-02	16	D-2	0.200	0.026	0.065	0.018	0.840	0.310	0.100	0.300	0.200	0.060	-----	-----	0.015	0.030	0.010
			-----	0.014	0.045	0.008	-----	0.220	BSC	BSC	0.125	0.015	0.005	-----	-----	-----	
-03	20	D-8	0.200	0.026	0.065	0.018	1.060	0.310	0.100	0.300	0.200	0.070	-----	-----	0.015	0.030	0.010
			-----	0.014	0.045	0.008	-----	0.220	BSC	BSC	0.125	0.015	0.005	-----	-----	-----	

Flatpack Packages

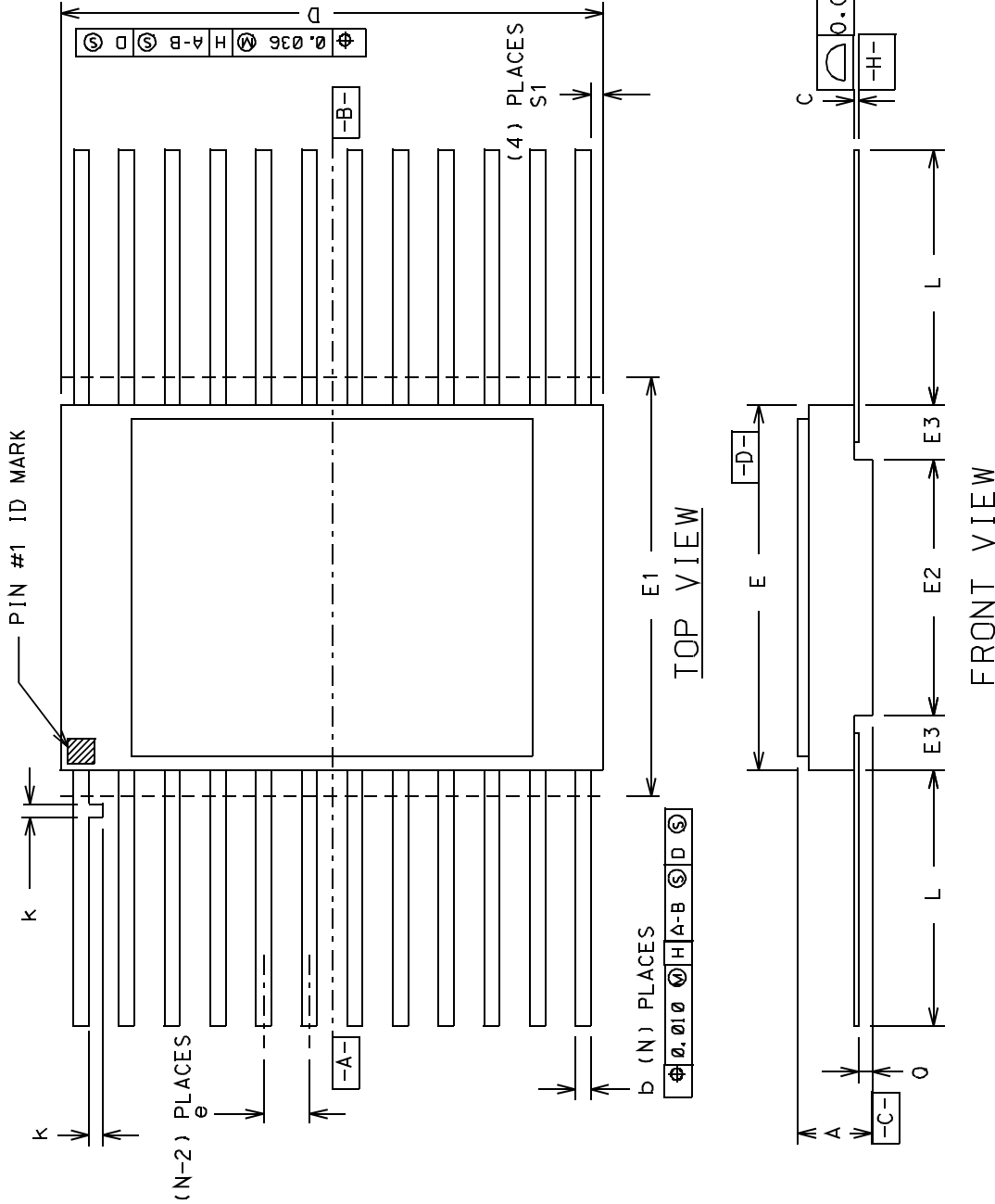

PKG CONFIG	LEAD COUNT	MIL-STD 1835 DWG CONF B	DIMENSION SYMBOLS											
			A	B	C	D	E	E1	E2	E3	e	k	L	Q
-03	14	F-2A	0.115 0.045	0.022 0.015	0.009 0.004	0.390 -----	0.260 0.235	0.290 -----	0.130 0.130	0.050 BSC	0.015 0.008	0.370 0.270	0.045 0.026	----- 0.005
-04	16	F-5A	0.115 0.045	0.022 0.015	0.009 0.004	0.440 -----	0.285 0.245	0.315 -----	0.130 0.130	0.050 BSC	0.015 0.008	0.370 0.250	0.045 0.026	----- 0.005
-05	20	F-9A	0.115 0.045	0.022 0.015	0.009 0.004	0.540 -----	0.300 0.245	0.330 -----	0.130 0.130	0.050 BSC	0.015 0.008	0.370 0.250	0.045 0.026	----- 0.000

3.0 ORDERING INFORMATION

RadHard MSI - 14-Lead Packages: Military Temperature Range

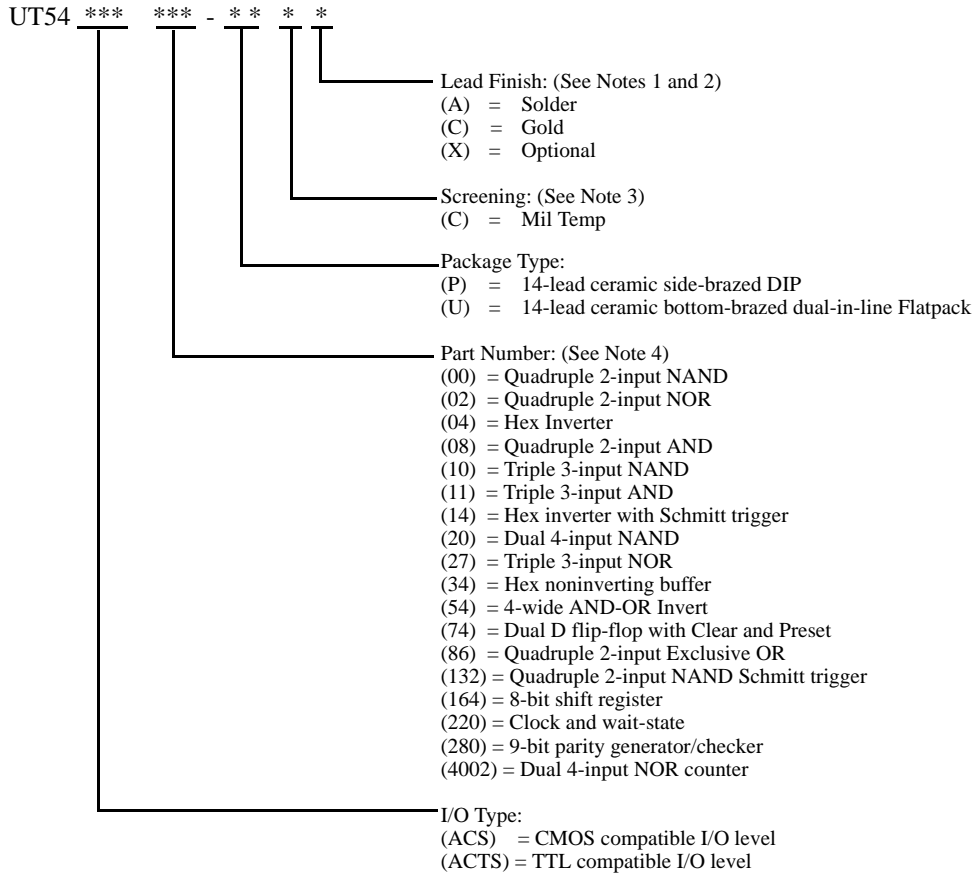

Notes:

1. Lead finish (A,C, or X) must be specified.
2. If an "X" is specified when ordering, then the part marking will match the lead finish and will be either "A" (solder) or "C" (gold).
3. Military Temperature Range flow per UTMC Manufacturing Flows Document. Devices have 48 hours of burn-in and are tested at -55C, room temperature, and 125C. Radiation characteristics are neither tested nor guaranteed and may not be specified.
4. The following devices are not available in a DIP package: UT54ACS14 and UT54ACS132.

ORDERING INFORMATION

RadHard MSI - 16-Lead Packages: Military Temperature Range

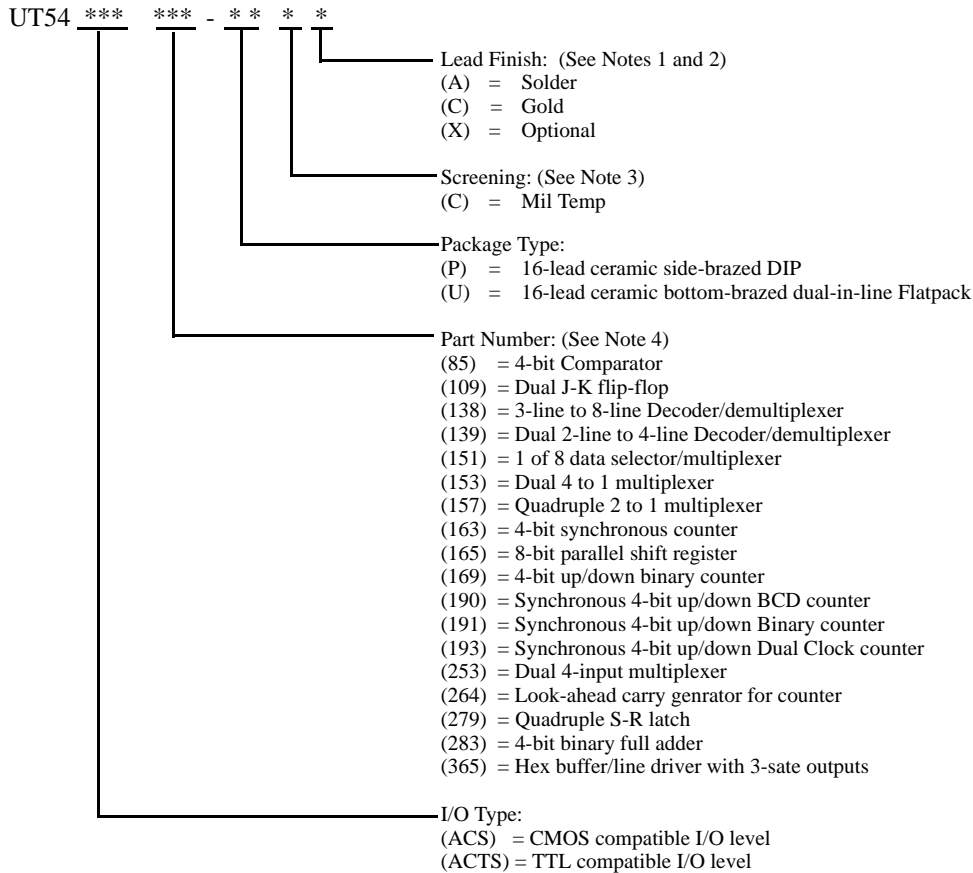

Notes:

1. Lead finish (A,C, or X) must be specified.
2. If an "X" is specified when ordering, then the part marking will match the lead finish and will be either "A" (solder) or "C" (gold).
3. Military Temperature Range flow per UTMC Manufacturing Flows Document. Devices have 48 hours of burn-in and are tested at -55C, room temperature, and 125C. Radiation characteristics are neither tested nor guaranteed and may not be specified.
4. The following devices are not available in a DIP package: UT54ACS109.

ORDERING INFORMATION

RadHard MSI - 20-Lead Packages: Military Temperature Range

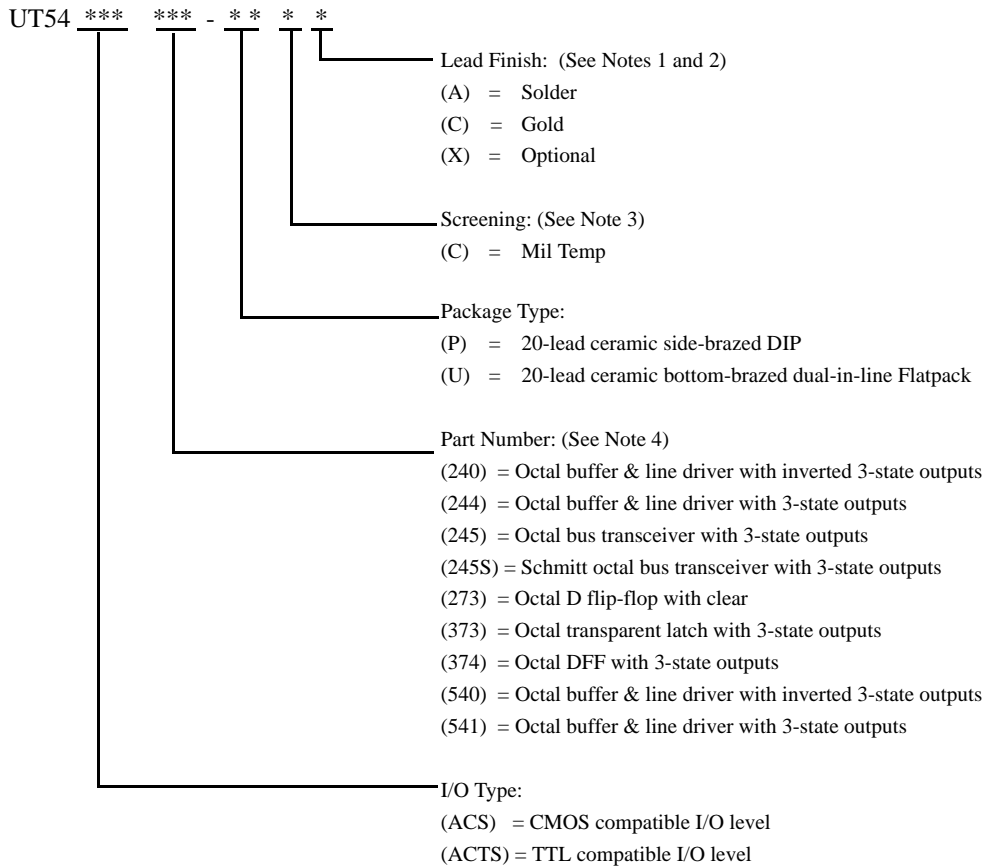

Notes:

1. Lead finish (A,C, or X) must be specified.
2. If an "X" is specified when ordering, then the part marking will match the lead finish and will be either "A" (solder) or "C" (gold).
3. Military Temperature Range flow per UTMC Manufacturing Flows Document. Devices have 48 hours of burn-in and are tested at -55C, room temperature, and 125C. Radiation characteristics are neither tested nor guaranteed and may not be specified.
4. The following devices are not available in a DIP package: UT54ACTS541.

RadHard MSI: SMD, Class Q & Class V

5962 * ***** 01 * * *

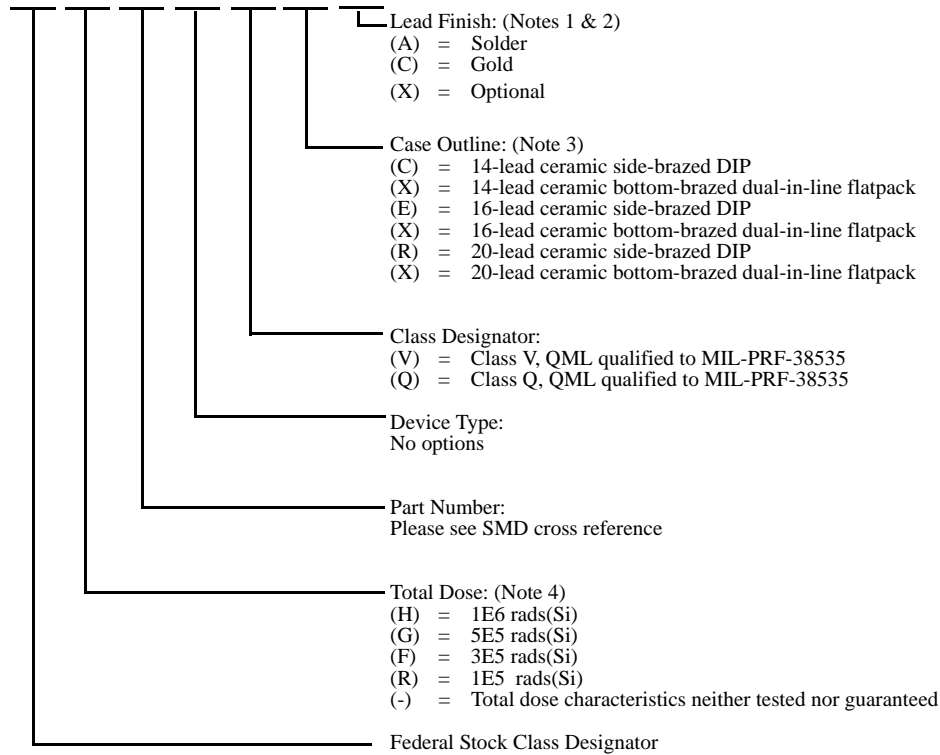

Notes:

1. Lead finish (A, C, or X) must be specified.
2. If an "X" is specified when ordering, part marking will match the lead finish and will be either "A" (solder) or "C" (gold).
3. Products listed in the SMD Cross Reference with a ♣ mark can only be procured in a bottom-brazed dual-in-line flatpack.
4. Products listed in the SMD Cross Reference with a ♣ mark can only be procured with a total dose guarantee of -, R, F, and G.