



A passion for performance.

**UT699 LEON 3FT**  
from Aeroflex  
Colorado Springs

**Designed for operation  
in harsh environments**

**Fault Tolerant architecture**

**Guaranteed radiation  
performance**

**Real-time operating  
system support**

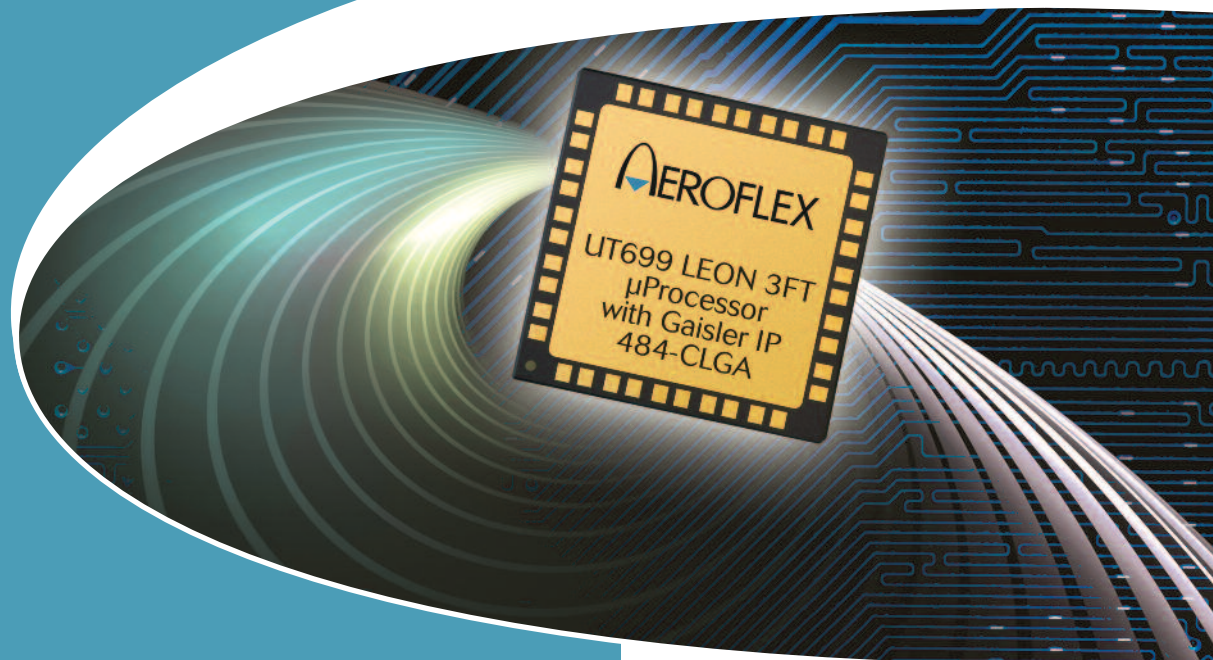

**LEON 3FT V8 SPARC™**  
**Microprocessor**

It's a fact

## Definitions

### LEON $\mu$ processor

LEON is a 32-bit CPU micro-processor core, based on the SPARC™ V8 RISC architecture and instruction set. The core is highly configurable, and suitable particularly for system-on-chip (SOC) designs. LEON 3FT is a Fault-Tolerant (FT) version, designed for operation in harsh, radiation-prone environments, and includes functionality to detect and correct single bit upset errors in all on-chip RAM memories.

## Definitions

### SPARC™ architecture

SPARC (Scalable Processor Architecture) is a RISC (Reduced Instruction Set Computing) architecture developed by Sun Microsystems. SPARC is a registered trademark of SPARC International, Inc., an organization established to create a larger ecosystem for the design by promoting, licensing, and providing conformance testing. As a result, the SPARC architecture is fully open and non-proprietary.

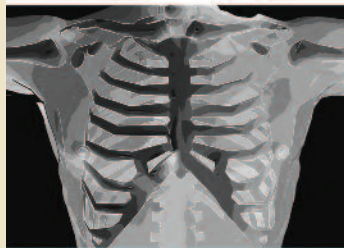
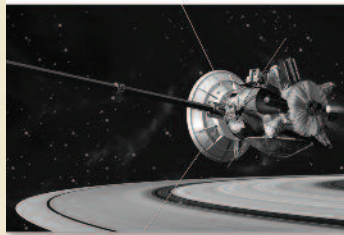

WE OFFER DEVELOPMENT TOOLS AND REAL-TIME OPERATING SYSTEM SUPPORT...

An advantage to working with Aeroflex's UT699 is the extensive library of development tools. Since the UT699 is SPARC™ V8 compliant, compilers and kernels for SPARC V8 are based on industry standard development tools.

Aeroflex offers a full software development suite including a C/C++ cross-compiler system based on GCC and the Newlib embedded C-library. The BCC compiler system allows cross-compilation of C and C++ applications for the LEON 3FT family.

For multi-threaded applications, SPARC-compliant ports are available for the following operating systems: eCos, RTEMS, Linux, VxWorks, Nucleus, ThreadX and LynxOS.

To support the software development process, a simulator and a debugger are available. TSIM is a high-performance SPARC-architecture instruction simulator capable of emulating the UT699 LEON 3FT. GRMON is a debug monitor for the UT699 processor. It communicates with the UT699 debug support unit (DSU) and allows non-intrusive debugging of the complete target system.

### ...PLUS PROVEN IP

The Aeroflex Gaisler GRLIB IP Library is an integrated set of reusable IP cores, designed for system-on-chip (SOC) development. The IP cores are centered around the common on-chip bus and use a coherent method for simulation and synthesis. The library is vendor independent, with support for different CAD tools and target technologies. A unique plug-and-play method is used to configure and connect the IP cores without the need to modify any global resources.

[www.aeroflex.com/Leon](http://www.aeroflex.com/Leon) 800-645-8862



# Aeroflex offers the best software support

## UT699 Software Development Tools (Debug)

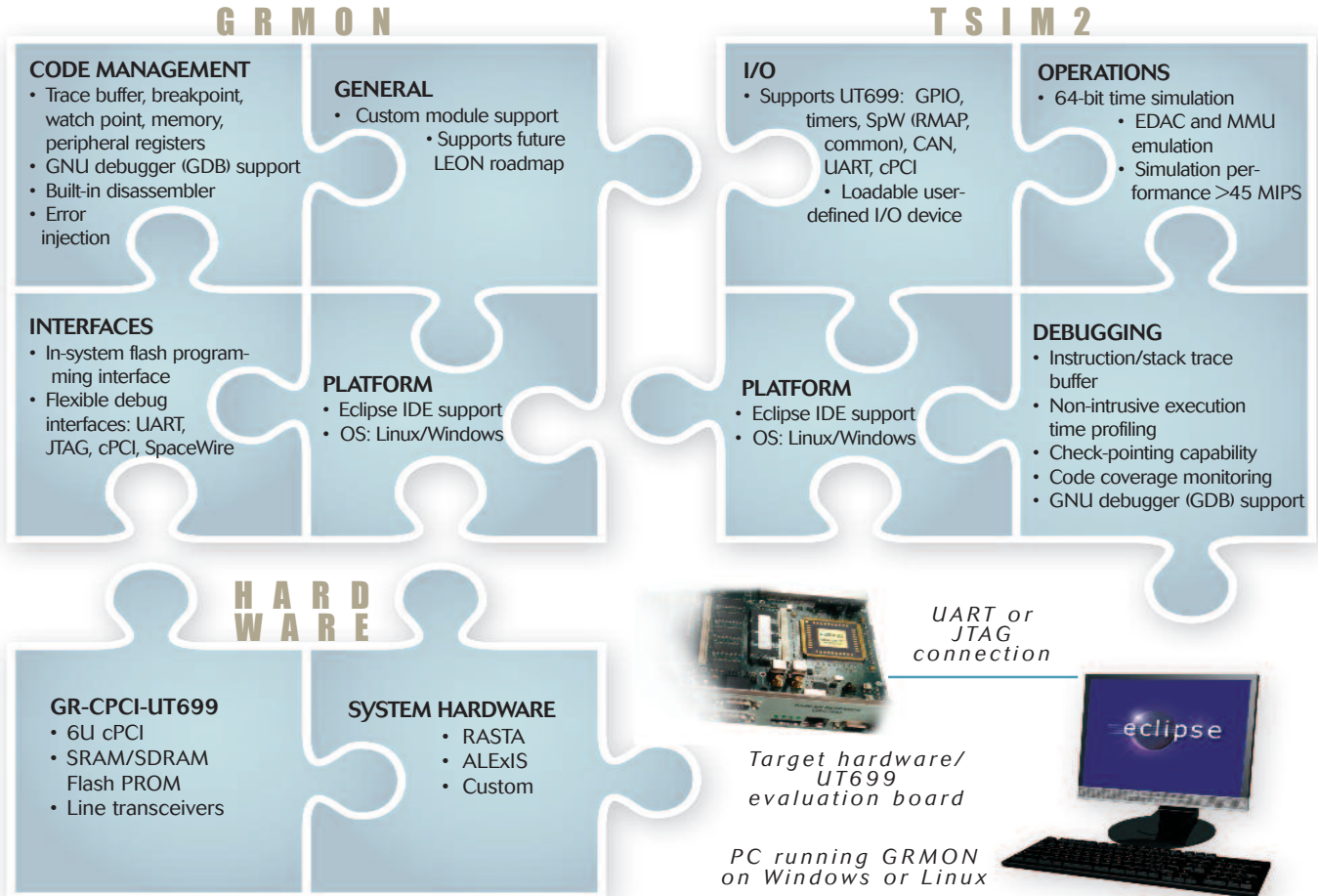

## UT699 Operating Systems Options (RTOS)

REAL-TIME OPERATING SYSTEMS	SUPPLIED DRIVERS						PLATFORM OS		FOOTPRINT			COST		
	SpW	UART	Ethernet	CAN	PCI	Timer	IRQ	Linux	Windows	< 70kB	70-150kB	> 150kB	License	Free
RTEMS	■	■	■	■	■	■	■	■	■	■				■
eCos		■	■			■	■	■	■	■				■
Nucleus		■	■			■	■	■	■				■	
LynxOS		■	■			■	■	■	■				■	
ThreadX		■	■			■	■	■	■	■				
VxWorks	■	■	■	■	■	■	■	■	■				■	
Snapgear Linux		■	■		■	■	■	■				■		■

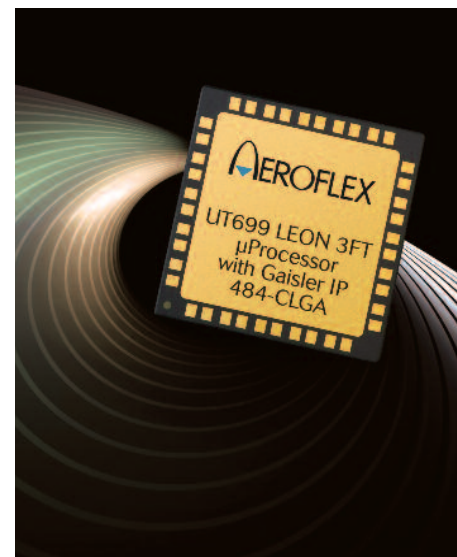

## LEON IDE featuring



- Eclipse-based C/C++ integrated development environment
- Code entry, build system, and debugging provided
- Support for debugging on real hardware through GRMON or on a simulator through TSIM
- Support for different toolchains, templates for RTEMS/RCC, BCC, Nucleus, ThreadX, and eCos
- Source-level debugging and disassembly view
- Variables, memory, and register view
- Support for Linux and Windows host platforms

## LEON Integrated Development Environment (IDE)

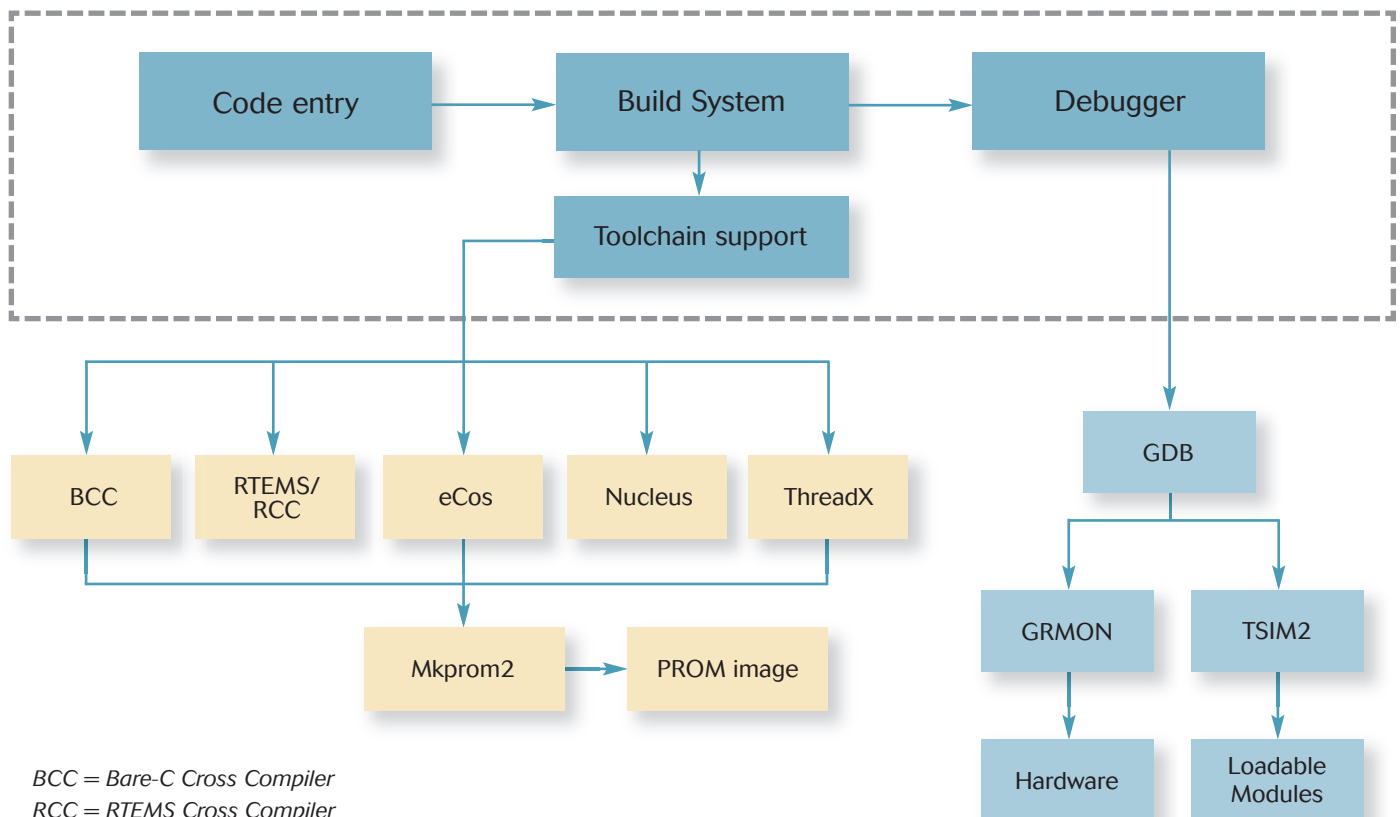

BCC = Bare-C Cross Compiler  
RCC = RTEMS Cross Compiler  
GDB = GNU debugger  
Mkprom2 = Make prom utility

# UT699 is dedicated to HiRel

## UT699 FEATURES

- Implemented on a 0.25µm CMOS technology
- Flexible static design allows up to 66MHz clock rate
- 89DMIPS throughput via 66MHz base clock frequency
- On-board programmable timers, interrupt controllers
- High-performance dual-precision IEEE-754 FPU
- Power-saving 2.5V core power supply; 3.3V I/O
- Hardened-by-design flip-flops and memory cells

## UT699 CORES

AMBA bus interconnects a peripheral rich environment:

- 10/100 Base-T Ethernet port
- Integrated PCI 2.2 compatible core
- Four integrated multi-protocol SpaceWire nodes with two supporting the RMAP target protocol in hardware
- Two CAN 2.0 compliant bus interfaces
- Multifunctional memory controller with EDAC

## UT699 GUARANTEED RADIATION PERFORMANCE / OPERATIONAL ENVIRONMENT

PARAMETER	LIMIT	UNITS
Total Ionizing Dose (TID)	3E5	rads(Si)
Single Event Latchup (SEL)	>108	MeV-cm <sup>2</sup> /mg
Neutron Fluence	1.0E14	n/cm <sup>2</sup>

## UT699 BLOCK DIAGRAM

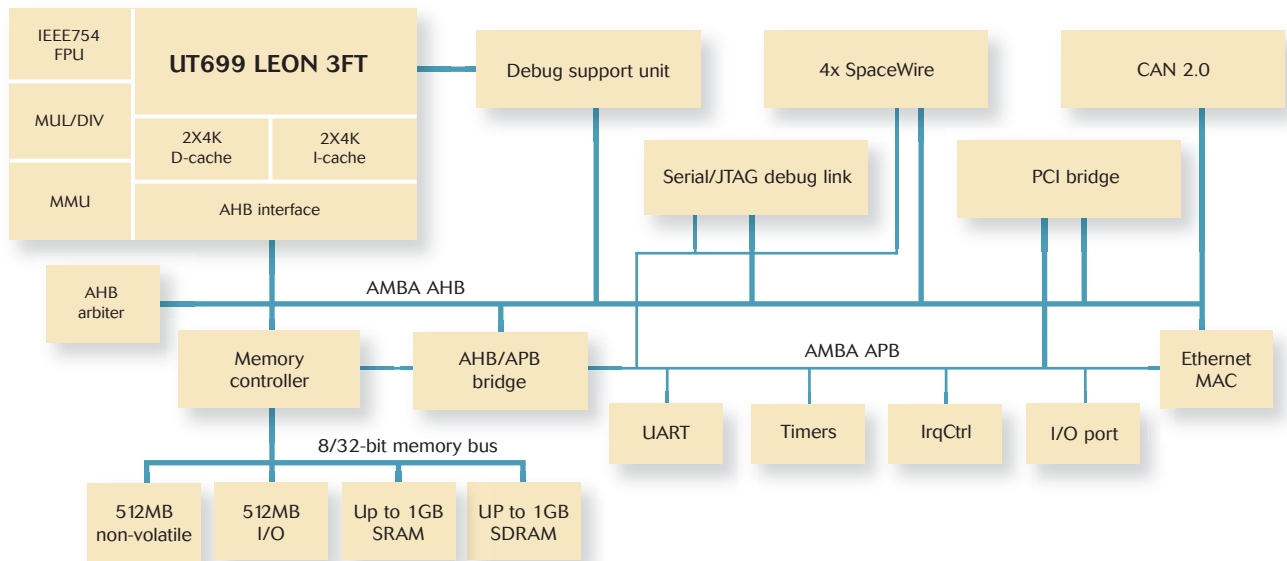

## NOTIONAL SINGLE BOARD COMPUTER

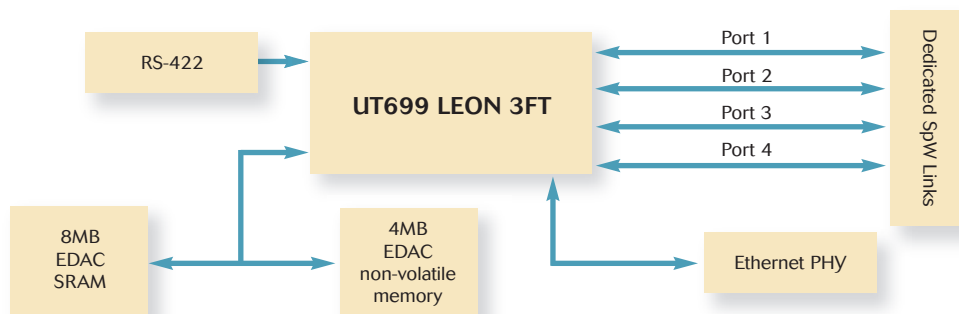

## LEON UT699 3FT SPARC™ V8 MICROPROCESSOR EVALUATION BOARD

The GR-CPCI-UT699 development board is capable of running at a system clock speed of 66MHz. The board is a 6U cPCI form factor and can also be used in a standalone bench-top configuration. The board supports 32-bit/33MHz PCI, 10/100 Base-T Ethernet, four SpaceWire ports capable of running up to 200Mbps/s, two CAN ports, on-board FLASH, SRAM, and SDRAM. A socket for a PROM device and a USB debug port are also on-board.

### ALEXIS

ALEXIS (Aeroflex LEON Experimenter's Interface System) is a ready-to-run development platform for customer applications with flexible architecture supporting quick path-to-flight after development. Flight and non-flight versions of the UT699-based single board computer of the ALEXIS are available. The ALEXIS platform provides two cPCI slots for future card expansion, and pre-loaded operating systems and applications drivers.

### RASTA

The Aeroflex Gaisler implementation of the RASTA (Reference Avionics System Testbed Activity) aims to provide a standardized hardware and software infrastructure for development, prototyping and validation of on-board systems. It allows quick and easy integration of complete systems in a lab environment, using standardized interfaces and connectors. It also provides access to LEON3 technology (through FPGA, ASIC, or products like UT699).

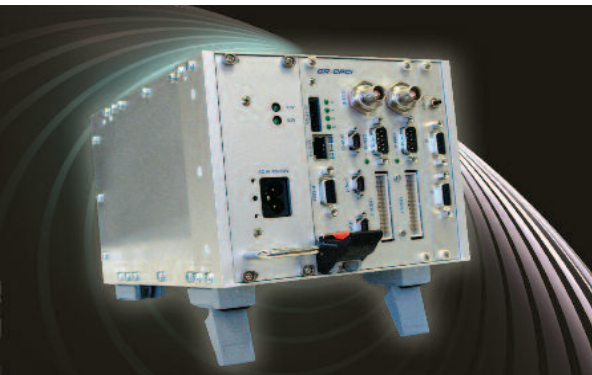
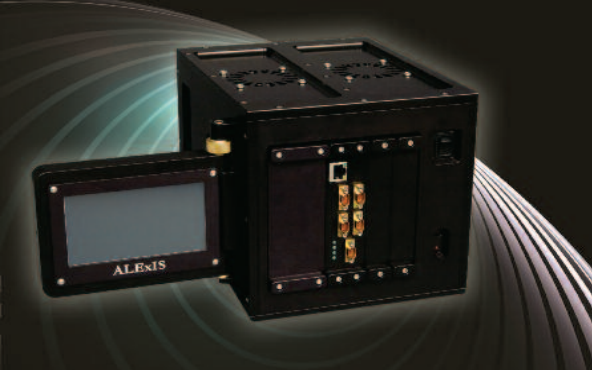
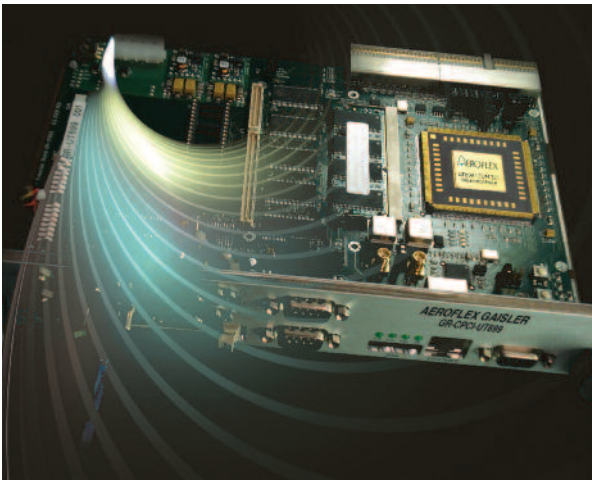

Aeroflex Colorado Springs

**WEB SITE** [www.aeroflex.com/leon](http://www.aeroflex.com/leon)  
[www.aeroflex.com/gaisler](http://www.aeroflex.com/gaisler)

**TELEPHONE** 800-645-8862

**AEROFLEX**  
A passion for performance.



Our passion for performance is defined by three attributes represented by these three icons: solution-minded, performance-driven and customer-focused.