

ENHANCED S μ MMITTM FAMILY Product Handbook

Aeroflex Colorado Springs, Inc.
4350 Centennial Blvd.
Colorado Springs, CO 80907

April 2012

Table of Contents

| | |
|---|----|
| 1.0 INTRODUCTION | 1 |
| 1.1 Remote Terminal Features | 1 |
| 1.1.1 Indexing | 1 |
| 1.1.2 Buffer Ping-Pong | 1 |
| 1.1.3 Circular Buffers | 1 |
| 1.1.4 Internal Illegalization | 1 |
| 1.1.5 Broadcast | 1 |
| 1.1.6 Interrupt History | 1 |
| 1.1.7 Message Information | 1 |
| 1.2 Bus Controller Features | 1 |
| 1.2.1 Multiple Message Processing | 2 |
| 1.2.2 Message Scheduling | 2 |
| 1.2.3 Polling | 2 |
| 1.2.4 Automatic Retry | 2 |
| 1.3 Monitor Terminal Features | 2 |
| 1.3.1 Message Information | 2 |
| 1.4 Remote Terminal/Monitor Terminal Features | 2 |
| 1.5 Protocol Definition | 2 |
| 1.6 S μ MMIT Transceivers | 2 |
| 1.7 S μ MMIT XTE Memory | 2 |
| | |
| 2.0 REMOTE TERMINAL ARCHITECTURE | 6 |
| 2.1 Register Descriptions | 6 |
| 2.1.1 Control Register | 6 |
| 2.1.2 Operational Status Register | 8 |
| 2.1.3 Current Command Register | 9 |
| 2.1.4 Interrupt Mask Register | 10 |
| 2.1.5 Pending Interrupt Register | 10 |
| 2.1.6 Interrupt Log List Pointer Register | 12 |
| 2.1.7 Bit Word Register | 12 |
| 2.1.8 Time-Tag Register | 13 |
| 2.1.9 Remote Terminal Descriptor Pointer Register | 13 |
| 2.1.10 1553 Status Word Bits Register | 14 |
| 2.1.11 Illegalization Registers | 16 |
| 2.2 Descriptor Block | 18 |
| 2.2.1 Receive Control Word | 21 |
| 2.2.2 Transmit Control Word | 22 |
| 2.2.3 Mode Code Receive Control Word | 23 |
| 2.2.4 Mode Code Transmit Control Word | 24 |
| 2.2.5 Data Pointer A and B | 25 |
| 2.2.6 Broadcast Data Pointer | 25 |
| 2.3 Data Structures | 25 |
| 2.3.1 Subaddress Receive Data | 28 |
| 2.3.2 Subaddress Transmit Data | 28 |

| | | |
|------------|--|-----------|
| 2.3.2.1 | Transmit Information (Info) Word | 29 |
| 2.3.3 | Mode Code Data | 29 |
| 2.3.3.1 | Mode Code Receive Information (Info) Word | 30 |
| 2.3.3.2 | Mode Code Transmit Information (Info) Word | 30 |
| 2.4 | Mode Code and Subaddress | 31 |
| 2.5 | Encoder and Decoder | 33 |
| 2.6 | RT-RT Transfer Compare | 33 |
| 2.7 | Terminal Address | 33 |
| 2.8 | Reset | 33 |
| 2.9 | MIL-STD-1553A Operation | 34 |
| 3.0 | BUS CONTROLLER ARCHITECTURE | 35 |
| 3.1 | Register Descriptions | 35 |
| 3.1.1 | Control Register | 36 |
| 3.1.2 | Operational Status Register | 37 |
| 3.1.3 | Current Command Register | 38 |
| 3.1.4 | Interrupt Mask Register | 38 |
| 3.1.5 | Pending Interrupt Register | 39 |
| 3.1.6 | Interrupt Log List Pointer Register | 40 |
| 3.1.7 | BIT Word Register | 40 |
| 3.1.8 | Minor Frame Timer Register | 40 |
| 3.1.9 | Command Block Pointer Register | 41 |
| 3.1.10 | BC Command Block Initialization Control Register | 41 |
| 3.2 | SBC Architecture | 42 |
| 3.2.1 | Control Word | 43 |
| 3.2.1.1 | Opcode Definition | 44 |
| 3.2.1.2 | Condition Codes | 45 |
| 3.2.2 | Command Words | 45 |
| 3.2.3 | Data Pointer | 45 |
| 3.2.4 | Status Words | 46 |
| 3.2.5 | Branch Address | 46 |
| 3.2.6 | Timer Value | 46 |
| 3.3 | Command Block Chaining | 46 |
| 3.4 | Memory Architecture | 48 |
| 3.5 | Message Processing | 49 |
| 3.6 | MIL-STD-1553A Operation | 50 |
| 4.0 | MONITOR TERMINAL ARCHITECTURE | 51 |
| 4.1 | Register Descriptions | 51 |
| 4.1.1 | Control Register | 52 |
| 4.1.2 | Operational Status Register | 53 |
| 4.1.3 | Current Command Register | 54 |
| 4.1.4 | Interrupt Mask Register | 54 |
| 4.1.5 | Pending Interrupt Register | 55 |
| 4.1.6 | Interrupt Log List Pointer Register | 55 |
| 4.1.7 | BIT Word Register | 56 |
| 4.1.8 | Time-Tag Register | 56 |
| 4.1.9 | Initial Monitor Block Pointer Register | 56 |

| | | |
|------------|--|-----------|
| 4.1.10 | Initial Monitor Data Pointer Register | 57 |
| 4.1.11 | Monitor Block Counter Register | 57 |
| 4.1.12 | Monitor Filter Register | 57 |
| 4.1.13 | Monitor Filter Register | 57 |
| 4.2 | SMT Architecture | 58 |
| 4.2.1 | Message Information Word | 58 |
| 4.2.1.1 | Message Information Bits | 59 |
| 4.2.2 | Command Words | 59 |
| 4.2.3 | Data Pointer | 59 |
| 4.2.4 | Status Words | 59 |
| 4.2.5 | Time-Tag | 59 |
| 4.2.6 | Unused | 59 |
| 4.3 | Monitor Block Chaining | 60 |
| 4.4 | Memory Architecture | 60 |
| 4.5 | Message Processing | 61 |
| 4.5.1 | Error Condition Message Processing | 61 |
| 4.6 | Remote Terminal/Monitor Terminal Operation | 61 |
| 4.7 | MIL-STD-1553A Operation | 62 |
| 5.0 | ENHANCED SμMMIT FAMILY OPERATION | 63 |
| 5.1 | Message Time-out | 63 |
| 5.2 | DMA Time-out | 63 |
| 5.3 | Circular Buffers | 63 |
| 5.3.1 | Mode Number 0 | 63 |
| 5.3.2 | Mode Number 1 | 63 |
| 5.3.3 | Mode Number 2 | 64 |
| 5.4 | Ping-Pong Handshake | 64 |
| 5.5 | Circular Buffer #1 | 64 |
| 5.6 | Circular Buffer #2 | 66 |
| 5.7 | Ping-Pong Enable/Disable Handshake | 68 |
| 6.0 | INTERRUPT ARCHITECTURE | 71 |
| 6.1 | S μ MMIT E & S μ MMIT LXE/DXE | 71 |
| 6.1.1 | Interrupt Identification Word (IIW) | 71 |
| 6.1.2 | Interrupt Address Word (IAW) | 71 |
| 6.1.3 | Interrupt Log List Address | 71 |
| 6.2 | S μ MMIT XTE | 74 |
| 6.2.1 | Interrupt Identification Word (IIW) | 74 |
| 6.2.2 | Interrupt Address Word (IAW) | 74 |
| 6.2.3 | Interrupt Log List Address | 74 |
| 7.0 | AUTO-INITIALIZATION | 76 |
| 7.1 | S μ MMIT E & S μ MMIT LXE/DXE | 76 |
| 7.1.1 | SRT Auto-Initialization | 76 |
| 7.1.2 | SMT Auto-Initialization | 76 |
| 7.1.3 | SBC Auto-Initialization | 76 |
| 7.1.4 | Auto-Initialization Hardware | 76 |
| 7.2 | S μ MMIT XTE | 78 |

| | | |
|-------------|---|------------|
| 7.2.1 | SRT Auto-Initialization | 78 |
| 7.2.2 | SMT Auto-Initialization | 78 |
| 7.2.3 | SBC Auto-Initialization | 78 |
| 7.2.4 | Auto-Initialization Hardware | 78 |
| 8.0 | TESTABILITY | 81 |
| 9.0 | SYSTEM CONFIGURATION | 82 |
| 9.1 | S μ MMIT E & S μ MMIT LX/DXE | 82 |
| 9.1.1 | Transmitter/Receiver Interface | 82 |
| 9.1.2 | Register Transfers | 83 |
| 9.1.3 | DMA Configuration | 84 |
| 9.1.4 | DMA Transfers | 84 |
| 9.1.5 | Buffer Mode Operation | 84 |
| 9.2 | S μ MMIT XTE | 87 |
| 9.2.1 | Internal Registers | 87 |
| 9.2.2 | Memory Map | 87 |
| 9.2.3 | Buffer Mode Operation | 87 |
| 9.2.4 | Hardware Interface | 87 |
| 10.0 | SERIAL DATA BUS INTERFACE | 94 |
| 10.1 | Transmitter | 94 |
| 10.2 | Receiver | 94 |
| 10.3 | Recommended Thermal Protection | 94 |
| 11.0 | SμMMIT PIN IDENTIFICATION AND DESCRIPTION | 97 |
| 11.1 | S μ MMIT Functional Pin Description | 98 |
| 11.1.1 | Data Bus | 98 |
| 11.1.2 | Address Bus | 99 |
| 11.1.3 | Remote Terminal Address Inputs | 99 |
| 11.1.4 | JTAG Testability Pins | 100 |
| 11.1.5 | Biphase Inputs | 100 |
| 11.1.6 | Biphase Outputs | 101 |
| 11.1.7 | DMA Signals | 101 |
| 11.1.8 | Control Signals | 103 |
| 11.1.9 | Status Signals | 103 |
| 11.1.10 | Power/Ground | 104 |
| 12.0 | SμMMIT LX/DX PIN IDENTIFICATION AND DESCRIPTION | 105 |
| 12.1 | S μ MMIT Functional Pin Description | 106 |
| 12.1.1 | Data Bus | 106 |
| 12.1.2 | Address Bus | 107 |
| 12.1.3 | Remote Terminal Address Inputs | 107 |
| 12.1.4 | JTAG Testability Pins | 108 |
| 12.1.5 | Biphase Inputs/Outputs | 108 |
| 12.1.6 | DMA Signals | 109 |
| 12.1.7 | Control Signals | 110 |

| | | |
|-------------|--|------------|
| 12.1.8 | Status Signals | 111 |
| 12.1.9 | Power/Ground | 112 |
| 13.0 | SμMMIT XT PIN IDENTIFICATION AND DESCRIPTION | 113 |
| 13.1 | S μ MMIT Functional Pin Description | 114 |
| 13.1.1 | Data Bus DA | 114 |
| 13.1.2 | Address Bus A(15:0) | 115 |
| 13.1.3 | Auto-initialization Address Bus EA(12:0) | 115 |
| 13.1.4 | Auto-initialization Data Bus ED(7:0) | 116 |
| 13.1.5 | Remote Terminal Address Inputs | 116 |
| 13.1.6 | JTAG Testability Pins | 117 |
| 13.1.7 | Biphase Inputs/Outputs | 117 |
| 13.1.8 | Control Signals | 118 |
| 13.1.9 | Status Signals | 120 |
| 13.1.10 | Power/Ground | 120 |
| 13.1.11 | No Comments | 121 |
| 14.0 | SμMMIT E ABSOLUTE MAXIMUM RATINGS | 122 |
| 15.0 | SμMMIT E RECOMMENDED OPERATING CONDITIONS | 122 |
| 16.0 | SμMMIT E DC ELECTRICAL CHARACTERISTICS | 123 |
| 17.0 | SμMMIT LXE/DXE & SμMMIT XTE ABSOLUTE MAXIMUM RATINGS | 124 |
| 18.0 | SμMMIT LXE/DXE & SμMMIT XTE RECOMMENDED OPERATING CONDITIONS | 125 |
| 19.0 | SμMMIXT LXE/DXE & SμMMIT XTE DC ELECTRICAL CHARACTERISTICS | 126 |
| 19.1 | S μ MMIT DXE & XTE DC Electrical Characteristics | 126 |
| 19.2 | S μ MMIT LXE & XTE (15 & 12) DC Electrical Characteristics | 127 |
| 19.3 | S μ MMIT DXE & XTE (5) DC Electrical Characteristics | 127 |
| 20.0 | SμMMIT E & SμMMIT LXE/DXE AC ELECTRICAL CHARACTERISTICS | 128 |
| 21.0 | SμMMIT XTE AC ELECTRICAL CHARACTERISTICS | 135 |
| 22.0 | SμMMIT LXE/DXE & SμMMIT XTE RECEIVER ELECTRICAL CHARACTERISTICS | 146 |
| 22.1 | S μ MMIT LXE & XTE (15 & 12) Receiver Electrical Characteristics | 146 |
| 22.2 | S μ MMIT DXE & XTE (5) Receiver Electrical Characteristics | 147 |

| | |
|--|-----|
| 23.0 SμMMIT LXE/DXE & SμMMIT XTE TRANSMITTER ELECTRICAL CHARACTERISTICS | 148 |
| 23.1 S μ MMIT LXE & XTE (15 & 12) Transmitter Electrical Characteristics | 148 |
| 23.2 S μ MMIT DXE & XTE (5) Transmitter Electrical Characteristics | 149 |
| 24.0 SμMMIT LXE/DXE & SμMMIT XTE AC ELECTRICAL CHARACTERISTICS | 150 |
| 24.1 S μ MMIT LXE & XTE (15 & 12) AC Electrical Characteristics | 150 |
| 24.2 S μ MMIT DXE & XTE (5) AC Electrical Characteristics | 150 |
| 25.0 PACKAGING | 153 |
| 26.0 ORDERING INFORMATION | 160 |
| APPENDIX 1 - UT63M1XX MIL-STD-1553A/B TRANSCEIVER | |
| APPENDIX 2 - UT63M14X MIL-STD-1553A/B TRANSCEIVER | |
| APPENDIX 3 - UT54ACTS220 - CLOCK AND WAIT-STATE CIRCUIT | |
| APPENDIX 4 - Step-by-Step Guide to 1553 Design Application Note | |

The SμMMIT™ FAMILY



1.0 INTRODUCTION

The monolithic μ MMIT provides the system designer with an intelligent solution to MIL-STD-1553 multiplexed serial data bus design problems. The μ MMIT is a single-chip device that implements all three of the defined MIL-STD-1553 functions - Remote Terminal, Bus Controller, and Monitor. Operating either autonomously or with a tightly coupled host, the μ MMIT will solve a wide range of MIL-STD-1553 interface problems. A powerful RISC processing unit provides automatic message handling, message status, general status, and interrupt information. The register-based interface architecture provides many programmable functions as well as extensive information pertinent to device maintenance. In either of the three operating modes, the μ MMIT can access up to 64K x 16 of external memory (65,536 x 16).

The μ MMIT (which derives its name from serial, μ -coded, monolithic, multi-mode, intelligent, terminal) is a powerful asset to a system designer solving the MIL-STD-1553 problem.

1.1 Remote Terminal Features

The μ MMIT Remote Terminal (SRT) conforms to the requirements of MIL-STD-1553B, Notice II. In addition to meeting the requirements of the standard, the SRT has an extensive list of flexible features to meet any MIL-STD-1553 interface requirement.

1.1.1 Indexing

The SRT can buffer up to 256 receive messages on a subaddress-by-subaddress basis. Upon reception of the specified number of messages, the SRT can generate an interrupt by signaling either the host or subsystem that data is ready for processing. The indexing feature is commonly used to implement bulk data transfer algorithms.

1.1.2 Buffer Ping-Pong

To support the transfer of periodic data, double buffering schemes are often incorporated into remote terminal designs. Periodic data transfer incorporates the use of two data buffers per subaddress. The remote terminal processes messages (receive or transmit) via the designated primary buffer. The host or subsystem uses the secondary buffer to collect new data for transmission or processing data received during the defined time interval. Upon completion of the defined interval, the remote terminal will switch the primary and secondary data buffers (i.e., ping-pong). The SRT supports ping-pong buffering via a user-selected ping-pong architecture consisting of dual subaddress data pointers.

1.1.3 Circular Buffers

μ MMIT circular buffer modes simplify the software service of remote terminals implementing bulk or periodic data transfers. The μ MMIT architecture allows the user to select one of two circular buffer modes. The user selects the preferred mode, at start-up, by writing to Control Register bits.

1.1.4 Internal Illegalization

An internal 256-bit (16 x 16) RAM allows for the illegalization of all mode codes and subaddresses. The illegalization RAM is accessed at the beginning of message processing to determine if the valid command is prohibited. To eliminate host or subsystem overhead, the μ MMIT can initialize the 256-bit illegalization RAM during the auto-initialization sequence.

1.1.5 Broadcast

Designed to meet the requirements of MIL-STD-1553B Notice II, the SRT can store all data associated with a broadcast command in separate memory from non-broadcast commands. This feature is user-selected via the Descriptor Control word and internal Control Register.

1.1.6 Interrupt History

A programmable interrupt structure allows the host or subsystem the flexibility to enter 16 interrupts into a 32-word buffer before service. This feature allows the logging of multiple interrupts if immediate service is restricted. The interrupt structure enters an Interrupt Information Word (IIW) and an Interrupt Address Word (IAW) indicating what subaddress or command block generated the interrupt. All modes of operation support interrupt logging.

1.1.7 Message Information

The SRT generates a Message Information Word and time-tag (16-bit) for all transacted messages. This information is written into memory along with message data words. The Message Information Word contains word count, message errors, and message type information.

1.2 Bus Controller Features

The μ MMIT Bus Controller (SBC) is a powerful MIL-STD-1553 bus controller developed to meet the requirements of multi-frame processing with low host overhead. User-defined decision making allows the SBC to operate autonomously from the host until a designated event or series of events has taken place.

1.2.1 Multiple Message Processing

The SBC architecture allows the chaining of multiple MIL-STD-1553 commands into major and minor frames depending on the application. This feature allows the host to structure message frames that perform independent tasks such as periodic data transfer, service requests, and bus diagnostics (initiate BIT). The SBC uses a simple opcode scheme to control the command block flow.

1.2.2 Message Scheduling

The SBC allows host entry of data to control the time between messages. This feature is useful when the BC has to perform periodic message transactions with multiple remote terminals.

1.2.3 Polling

The host instructs the SBC to interrogate the status word response of remote terminals to determine if any SBC action is required. The SBC can detect the assertion of status word bits and generate interrupts or branch to a new message frame. Polling is useful if the application requires control of message frame flow as a function of remote terminal response.

1.2.4 Automatic Retry

The SBC can automatically retry a message on busy, message error, or other status word bit response. If enabled, the SBC can retry up to four times, per command block, on the primary bus or alternate bus.

1.3 Monitor Terminal Features

The S μ MMIT Monitor Terminal (SMT) is a full-featured MIL-STD-1553B bus monitor designed to monitor all or selected remote terminals on the bus. Requiring little host intervention, the SMT will monitor selected remote terminals until a pre-defined message count is reached. Generation of an interrupt alerts the host that SMT service is required.

1.3.1 Message Information

Each message transaction generates a Message Information Word. This information helps determine message validity and remote terminal health. The Message Information Word is stored in external memory along with message data words.

1.4 Remote Terminal/Monitor Terminal Feature

For those applications that require the SMT to transfer or receive information, the S μ MMIT is configured as both a remote terminal (SRT) and monitor (SMT). This feature allows the SMT to communicate on the bus as a RT, and monitor bus activity. Configuration as both SMT and SRT precludes the SMT from monitoring its own remote terminal address.

1.5 Protocol Definition

For maximum flexibility, the S μ MMIT has been designed to operate in many different systems which use various protocols. Specifically, two of the protocols that the S μ MMIT may interface are MIL-STD-1553A and MIL-STD-1553B. To meet these protocols, the S μ MMIT may be configured through an external pin or through control register bits.

1.6 S μ MMIT LXE/DXE & XTE Transceivers

Internal monolithic transceivers are complete transmitter and receiver pairs for MIL-STD-1553A and 1553B applications. The receiver section accepts biphas-modulated Manchester II bipolar data from MIL-STD-1553 data bus and produces TTL-level signal data at its internal RXOUT and RXOUT outputs.

The transmitter section accepts biphas TTL-level signal data at its internal TXIN and $\overline{\text{TXIN}}$ inputs and produces MIL-STD-1553 data signals. The transmitter's output voltage is typically $10V_{P-P,LL}$ for the S μ MMIT XTE5 & DXE and $42V_{P-P,LL}$ for the S μ MMIT XTE15, XTE12 & LXE.

1.7 S μ MMIT XTE Memory

The S μ MMIT XTE contains 512 Kbits of internal memory for message processing. Internal logic generates a $\overline{\text{RDY}}$ signal for the subsystem interface. The internal memory is memory mapped.

S μ MMIT FEATURES

- ❑ Comprehensive MIL-STD-1553 dual redundant Bus Controller (BC), Remote Terminal (RT), and Monitor Terminal (MT)
- ❑ MIL-STD-1553B, Notice II RT
 - Internal command illegalization in the RT mode
 - 16-bit read/write time-tag with user-defined resolution
 - Subaddress data buffering
- ❑ Simultaneous RT/MT mode of operation
- ❑ Flexible BC architecture designed to off-load the host computer
 - Minor frame timing
 - Efficient command block flow statements (Branch, Go To, Call)
 - Status word polling
 - Programmable retries
- ❑ Programmable interrupt architecture with automatic interrupt logging available in all modes
- ❑ Autonomous operation in all three modes of operation
 - Ideal for low cost remote terminals
- ❑ Built-In Test capability
- ❑ Supports IEEE Standard 1149.1 (JTAG)
- ❑ Radiation-hardened option available
- ❑ Flexible packaging offering:
 - 84-pin pingrid array (PGA)
 - 84-lead flatpack
 - 132-lead flatpack
- ❑ Standard Microcircuit Drawing 5962-92118 available
 - QML Q & V compliant

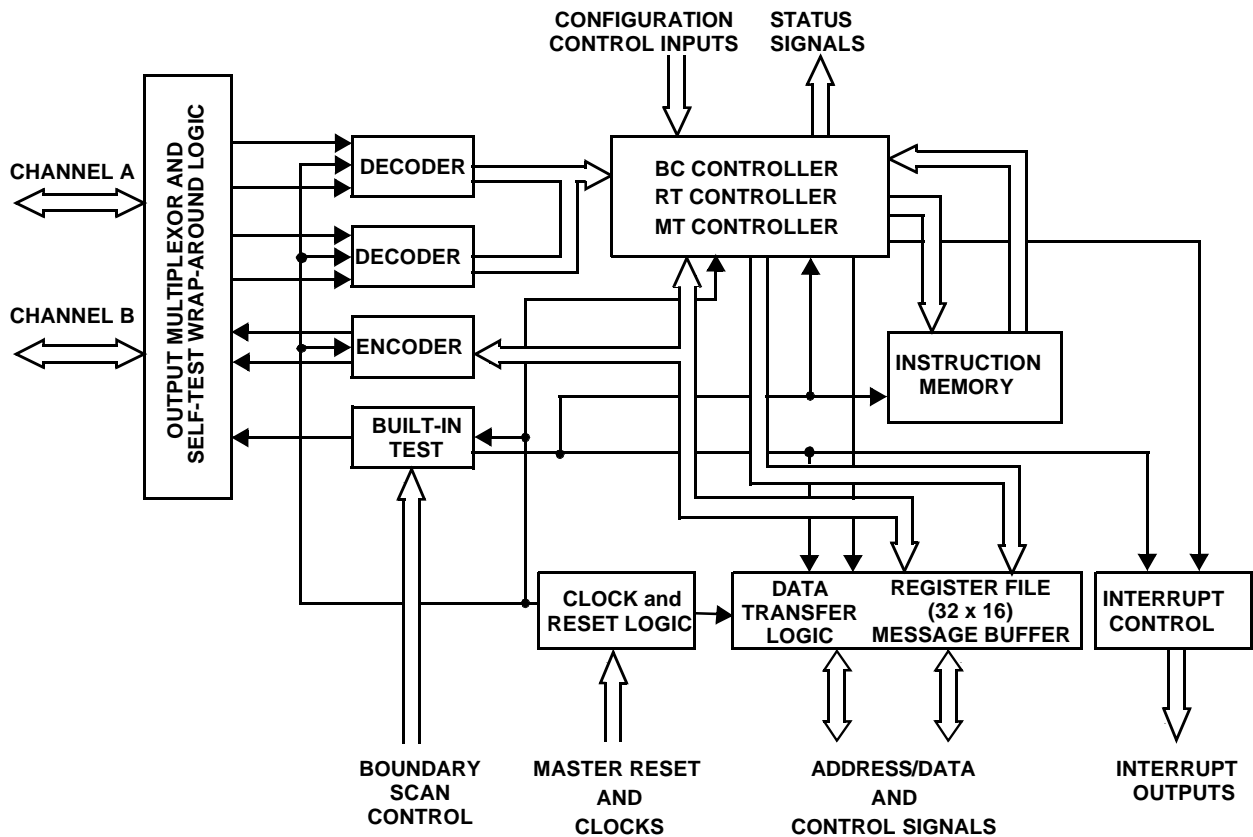

Figure 1. UT69151 S μ MMIT Block Diagram

LXE/DXE FEATURES

- ❑ Comprehensive MIL-STD-1553 dual redundant Bus Controller(BC), Remote Terminal (RT), and Monitor Terminal (MT) with integrated bus transceivers
- ❑ MIL-STD-1553B, Notice II RT
 - Internal command illegalization in the RT mode
 - 16-bit read/write time-tag with user-defined resolution
 - Subaddress data buffering
- ❑ Simultaneous RT/MT mode of operation
- ❑ Flexible BC architecture designed to off-load the host computer
 - Minor frame timing
 - Efficient command block flow statements (Branch, Go To, Call)
 - Status word polling
 - Programmable retries
- ❑ Programmable interrupt architecture with automatic interrupt logging available in all modes
- ❑ Autonomous operation in all three modes of operation
 - Ideal for low cost remote terminals
- ❑ Built-In Test capability
- ❑ Supports IEEE Standard 1149.1 (JTAG)
- ❑ Flexible power supply configurations
 - +5-volt only operation
 - -15-volt and 5-volt operation
 - -12-volt and 5-volt operation
- ❑ Radiation-hardened option available (LX version only)
- ❑ Flexible packaging offering:
 - 96-pin pingrid array (PGA)
 - 100-lead flatpack
 - Complete interface in 1.4 in²
- ❑ Standard Microcircuit Drawing 5962-94663
 - QML Q and V compliant

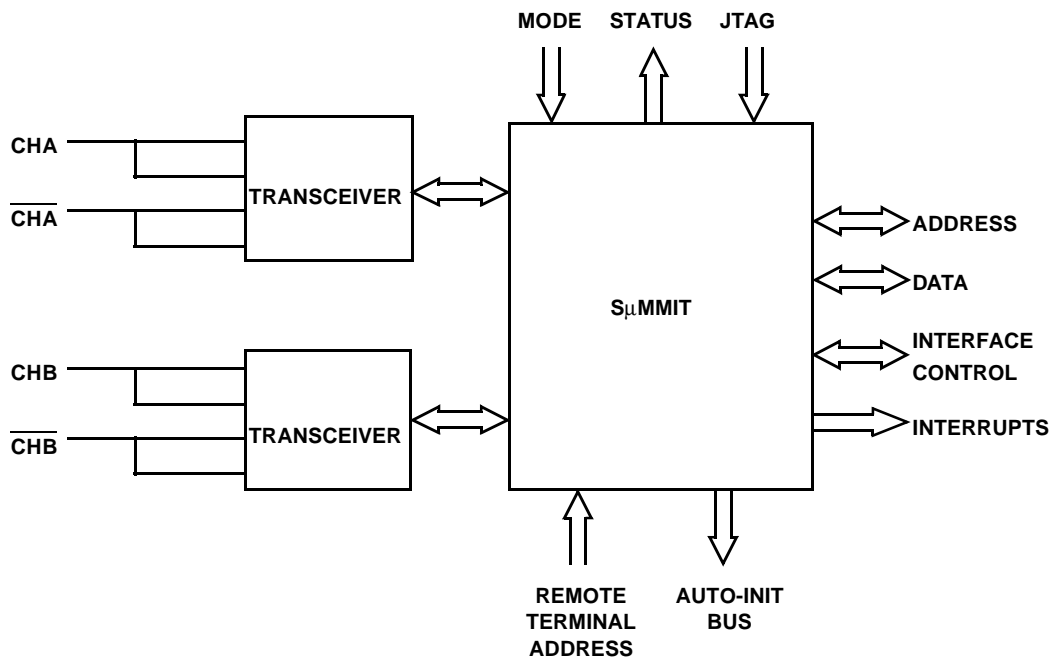

Figure 2. UT69151 SμMMIT LXE/DXE Block Diagram

XTE FEATURES

- ❑ Comprehensive MIL-STD-1553 dual redundant Bus Controller (BC), Remote Terminal (RT), and Monitor Terminal (MT) with integrated bus transceivers, Memory, and Memory Management Unit (MMU)
 - ❑ MIL-STD-1553B, Notice II RT
 - Internal command illegalization in the RT mode
 - 16-bit read/write time-tag with user-defined resolution
 - Subaddress data buffering
 - ❑ Simultaneous RT/MT mode of operation
 - ❑ Flexible BC architecture designed to off-load the host computer
 - Minor frame timing
 - Efficient command block flow statements (Branch, Go To, Call)
 - Status word polling
 - Programmable retries
 - ❑ Programmable interrupt architecture with automatic interrupt logging available in all modes
 - ❑ Autonomous operation in all three modes of operation
 - External initialization bus
 - Ideal for low cost remote terminals
- ❑ Internal Memory Management Unit (MMU) interfaces host subsystem to 512Kbit SRAM
 - Wait state and zero-wait state configurations
- ❑ Built-In Test capability
- ❑ Supports IEEE Standard 1149.1 (JTAG)
- ❑ Flexible power supply configurations
 - +5-volt only operation
 - -15-volt and 5-volt operation
 - -12-volt and 5-volt operation
- ❑ Flexible packaging offering:
 - 139-pin pingrid array (PGA)
 - 140-lead flatpack
 - Complete interface in 1.9 in²
- ❑ Standard Microcircuit Drawing 5962-94758
 - QML Q and V compliant

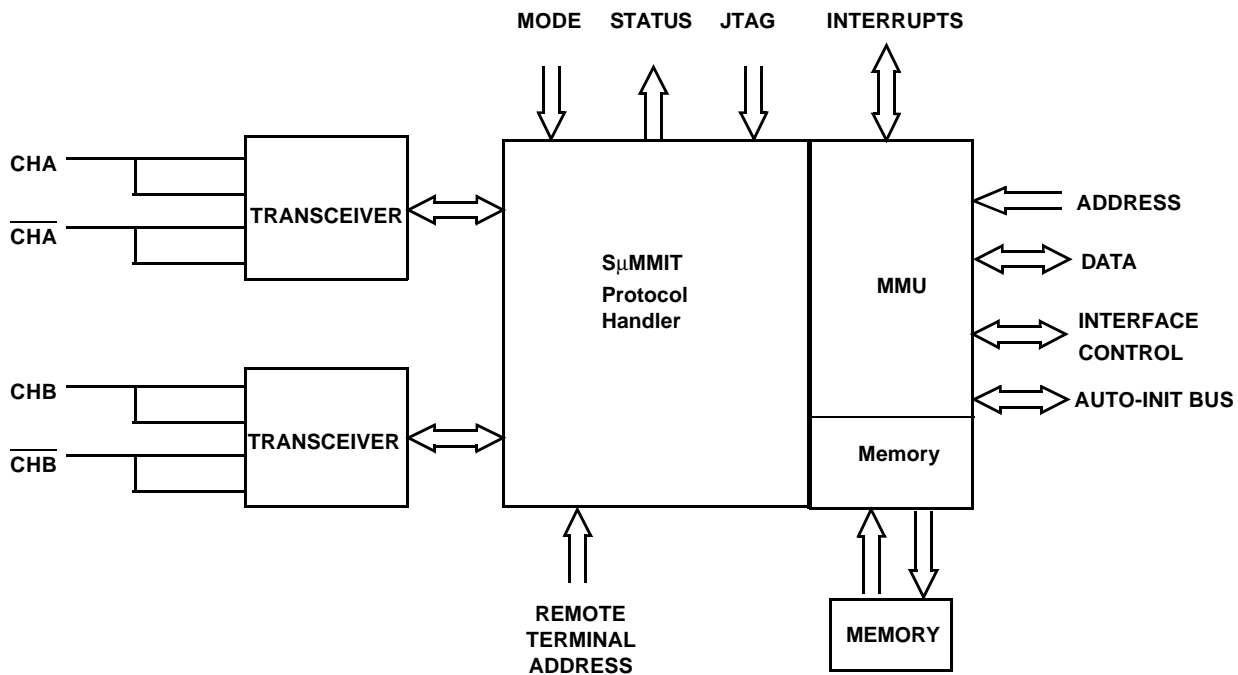

Figure 3. UT69151 SμMMIT XTE Block Diagram

2.0 REMOTE TERMINAL ARCHITECTURE

The S μ MMIT Remote Terminal (SRT) is an interface device linking a MIL-STD-1553 serial data bus to a host microprocessor and/or subsystem. The SRT's MIL-STD-1553 interface includes encoding/decoding logic, error detection, command recognition, DMA interface, control/configuration registers, clock, and reset logic. The following sections review

the architecture and use. Each section supplies information on the SRT's configuration and operation.

2.1 Register Descriptions

The following list provides the bit descriptions of the 32 internal registers that control SRT operation. All register bits are active high and reflect a logic zero condition (0000 hex) after Master Reset (except those reflecting input pins).

| Register Number | Name | Register Address |
|-----------------|-------------------------------------|--------------------|
| 0 | Control Register | 0000 (hex) |
| 1 | Operational Status Register | 0001 (hex) |
| 2 | Current Command Register | 0002 (hex) |
| 3 | Interrupt Mask Register | 0003 (hex) |
| 4 | Pending Interrupt Register | 0004 (hex) |
| 5 | Interrupt Log List Pointer Register | 0005 (hex) |
| 6 | BIT Word Register | 0006 (hex) |
| 7 | Time-Tag Register | 0007 (hex) |
| 8 | SRT Descriptor Pointer Register | 0008 (hex) |
| 9 | 1553 Status Word Bits Register | 0009 (hex) |
| 10-15 | Not Applicable | 000A to 000F (hex) |
| 16-31 | Illegalization Registers | 0010 to 001F (hex) |

Note: Reference section 9.1.2 for S μ MMIT XTE 8-bit register address numbers.

2.1.1 Control Register (Read/Write) - Register 0

This 16-bit register controls SRT configuration. To make changes to the SRT and this register, the STEX bit (Bit 15 of the Control Register) must be logic zero. Note: The user has 5 μ s after $\overline{\text{TERACT}}$ active to stop execution.

| Bit Number | Mnemonic | Description |
|------------|----------|---|
| 15 | STEX | Start Execution. Assertion of this bit initiates S μ MMIT operation. A Control Register write negating this bit inhibits S μ MMIT operation. A remote terminal address parity error prevents SRT operation regardless of the logical state of this bit. If a RT address parity error exists, bit 3 of Register 1 will be set low and bit 2 of Register 1 will be set high. |
| 14 | SBIT | Start BIT. Assertion of this bit places the S μ MMIT into the Built-In Test routine. The BIT test has a fault coverage of 93.4%. If the S μ MMIT has been started, the host must halt the device in order to place the S μ MMIT into the Built-In Test routine (STEX = 0) (see section 8.0 for additional information). Note: If Start BIT (SBIT) and Start Execution (STEX) are both set on one register write, BIT has priority. |

| Bit Number | Mnemonic | Description |
|------------|----------|--|
| 13 | SRST | Software Reset. Assertion of this bit immediately places the S μ MMIT into a software reset. The software reset (which takes 5 μ s to execute), like $\overline{\text{MRST}}$, clears all internal logic. Note: During auto-initialization this bit should not be loaded with a logic one. SRST will only function after $\overline{\text{READYB}}$ is asserted. |
| 12 | CHAEN | Channel A Enable. Setting this bit enables Channel A operation. If negated, the SRT does not recognize commands received over Channel A. |
| 11 | CHBEN | Channel B Enable. Setting this bit enables Channel B operation. If negated, the SRT does not recognize commands received over Channel B. |
| 10 | ETCE | External Timer Clock Enable. Assertion of this bit to a logic one allows the external timer clock input to supply stimulus to the internal time-tag counter. Refer to section 2.1.8 for additional information. Note: The user can only change the clock frequency before starting the device (i.e., setting bit 15 of Register 0 to a logic one). |
| 9-7 | -- | See section 5, Enhanced S μ MMIT Family Operation for additional information. |
| 6 | BUFR | Buffer Mode Enable. Assertion of this bit enables the buffer mode of operation. For more detailed information on this feature refer to sections 9.1.5 or 9.2.3. |
| 5 | N/A | Not Applicable. |
| 4 | BCEN | Broadcast Enable. Assertion of this bit enables the SRT broadcast option. Negation of this bit enables remote terminal address 31 as a unique remote terminal address. |
| 3 | DYNBC | Dynamic Bus Control Acceptance. This bit controls the SRT's ability to accept the dynamic bus control mode code. Assertion of this bit allows the SRT to respond to a dynamic bus control mode code with status word bit 18 set to a logic one. Negation of this bit prevents the assertion of status word bit 18 upon reception of the dynamic mode code. |
| 2 | PPEN | Ping-Pong Enable. Assertion of this bit enables the ping-pong buffer feature of the SRT and disables the message indexing feature. Negation of this bit disables the ping-pong feature and enables the message indexing feature. See section 5, Enhanced S μ MMIT Family Operation for additional information. |
| 1 | INTEN | Interrupt Log Enable. Assertion of this bit enables the S μ MMIT interrupt logging feature. Negation of this bit prevents the logging of interrupts. |
| 0 | XMTSW | Transmit Status Word. Assertion of this bit allows the SRT to automatically execute the TRANSMIT STATUS WORD mode code when configured for MIL-STD-1553A mode operation. Refer to section 2.9 for additional information. |

2.1.2 Operational Status Register (Read/Write) - Register 1

This register reflects pertinent status information for the SRT and is not reset to 0000 (hex) on $\overline{\text{MRST}}$. Instead, the register reflects the actual stimulus applied to input pins RTA(4:0), RTPTY, MSEL(1:0), A/B STD, and $\overline{\text{LOCK}}$. Assertion of the $\overline{\text{LOCK}}$ input prevents the modification of the remote terminal address, mode selects, and A or B Standard. In this case, a write to this register's most significant nine bits is meaningless. If $\overline{\text{LOCK}}$ is negated, a read of this register reflects the information written into this register's most significant nine bits.

Note: To make changes to the SRT and this register, the STEX bit (Bit 15 in Register 0) must be logic zero.

| Bit Number | Mnemonic | Description | | | | | | | | | | | | | | | |
|------------|----------|--|---------|---------|-------------------|---|---|-----|---|---|-----|---|---|-----|---|---|---------|
| 15 | RTA4 | Terminal Address Bit 4. This bit is the most significant bit of the remote terminal address. This bit is latched on the rising edge of $\overline{\text{MRST}}$ and is a read only bit if the $\overline{\text{LOCK}}$ pin is active. | | | | | | | | | | | | | | | |
| 14 | RTA3 | Terminal Address Bit 3. This bit is Bit 3 of the remote terminal address. This bit is latched on the rising edge of $\overline{\text{MRST}}$ and is a read only bit if the $\overline{\text{LOCK}}$ pin is active. | | | | | | | | | | | | | | | |
| 13 | RTA2 | Terminal Address Bit 2. This bit is Bit 2 of the remote terminal address. This bit is latched on the rising edge of $\overline{\text{MRST}}$ and is a read only bit if the $\overline{\text{LOCK}}$ pin is active. | | | | | | | | | | | | | | | |
| 12 | RTA1 | Terminal Address Bit 1. This bit is Bit 1 of the remote terminal address. This bit is latched on the rising edge of $\overline{\text{MRST}}$ and is a read only bit if the $\overline{\text{LOCK}}$ pin is active. | | | | | | | | | | | | | | | |
| 11 | RTA0 | Terminal Address Bit 0. This bit is the least significant bit of the remote terminal address. This bit is latched on the rising edge of $\overline{\text{MRST}}$ and is a read only bit if the $\overline{\text{LOCK}}$ pin is active. | | | | | | | | | | | | | | | |
| 10 | RTPTY | Terminal Address Parity Bit. This bit is appended to the remote terminal address bus (RTA(4:0)) to supply odd parity. The SRT requires odd parity for proper operation. This bit is latched on the rising edge of $\overline{\text{MRST}}$ and is a read only bit if the $\overline{\text{LOCK}}$ pin is active. | | | | | | | | | | | | | | | |
| 9 | MSEL(1) | Mode Select 1. In conjunction with MSEL0, this bit determines the S μ MMIT mode of operation. This bit is latched on the rising edge of $\overline{\text{MRST}}$ and is a read only bit if the $\overline{\text{LOCK}}$ pin is active. | | | | | | | | | | | | | | | |
| 8 | MSEL(0) | Mode Select 0. In conjunction with MSEL1, this bit determines the S μ MMIT mode of operation. This bit is latched on the rising edge of $\overline{\text{MRST}}$ and is a read only bit if the $\overline{\text{LOCK}}$ pin is active. | | | | | | | | | | | | | | | |
| | | <table border="1"> <thead> <tr> <th>MSEL(1)</th> <th>MSEL(0)</th> <th>Mode of Operation</th> </tr> </thead> <tbody> <tr> <td>0</td> <td>0</td> <td>SBC</td> </tr> <tr> <td>0</td> <td>1</td> <td>SRT</td> </tr> <tr> <td>1</td> <td>0</td> <td>SMT</td> </tr> <tr> <td>1</td> <td>1</td> <td>SMT/SRT</td> </tr> </tbody> </table> | MSEL(1) | MSEL(0) | Mode of Operation | 0 | 0 | SBC | 0 | 1 | SRT | 1 | 0 | SMT | 1 | 1 | SMT/SRT |
| MSEL(1) | MSEL(0) | Mode of Operation | | | | | | | | | | | | | | | |
| 0 | 0 | SBC | | | | | | | | | | | | | | | |
| 0 | 1 | SRT | | | | | | | | | | | | | | | |
| 1 | 0 | SMT | | | | | | | | | | | | | | | |
| 1 | 1 | SMT/SRT | | | | | | | | | | | | | | | |
| 7 | A/B STD | Military Standard 1553A or 1553B Standard. This bit determines whether the SRT will be set to operate under MIL-STD-1553A or B. Assertion of this bit enables the XMTSW bit (Bit 0 of the Control Register). Negation of this bit automatically allows the SRT to operate under the MIL-STD-1553B protocol. This bit is latched on the rising edge of $\overline{\text{MRST}}$ and is a read only bit if the $\overline{\text{LOCK}}$ pin is active. See section 2.9 for further definition. | | | | | | | | | | | | | | | |
| 6 | LOCK | $\overline{\text{LOCK}}$ Pin. This read-only bit reflects the inverted state of input pin $\overline{\text{LOCK}}$ and is latched on the rising edge of $\overline{\text{MRST}}$. | | | | | | | | | | | | | | | |
| 5 | AUTOEN | $\overline{\text{AUTOEN}}$ Pin. This read-only bit reflects the inverted state of input pin $\overline{\text{AUTOEN}}$. Assertion of this input enables SRT auto-initialization. | | | | | | | | | | | | | | | |
| 4 | SSYSF | $\overline{\text{SSYSF}}$ Pin. This read-only bit reflects the inverted state of the input pin $\overline{\text{SSYSF}}$. | | | | | | | | | | | | | | | |

| Bit Number | Mnemonic | Description |
|------------|----------|---|
| 3 | EX | S μ MMIT Executing. This read-only bit indicates whether the SRT is presently executing or whether it is idle. A logic one indicates that the S μ MMIT is executing; logic zero indicates that the S μ MMIT is idle. |
| 2 | TAPF | Terminal Address Parity Fail. This bit indicates the observance of a terminal address parity error. The SRT checks for odd parity. This read only bit reflects the parity of Operational Status Register bits 15-10, and is latched on the rising edge of \overline{MRST} . |
| 1 | READY | \overline{READY} Pin. This read-only bit reflects the inverted state of the output pin \overline{READY} and is cleared on reset. |
| 0 | TERACT | \overline{TERACT} Pin. Assertion of this bit indicates that the SRT is presently processing a message. This read only bit reflects the inverted state of output pin \overline{TERACT} and is cleared on reset. |

Note: Remote Terminal Address and Parity checked on start of execution.

2.1.3 Current Command Register (Read-only) - Register 2

This 16-bit register contains the last valid command processed by the SRT.

| Bit Number | Mnemonic | Description |
|------------|----------|---|
| 15 to 0 | CC15-CC0 | Current Command Bits. This register contains the last valid command received by the SRT. This register is valid 13 μ s after \overline{TERACT} is active. (Bit 15 MSB - Bit 0 LSB). |

2.1.4 Interrupt Mask Register (Read/Write) - Register 3

The SRT interrupt architecture allows for the masking of all interrupts. An interrupt is masked if the corresponding bit of this register is set to logic zero. This feature allows the host or subsystem to temporarily disable the service of interrupts. While masked, interrupt activity does not occur. The unmasking of an interrupt after the event occurs does not generate an interrupt for that event.

| Bit Number | Mnemonic | Description |
|------------|----------|--|
| 15 | DMAF | DMA Fail Interrupt |
| 14 | WRAPF | Wrap Fail Interrupt |
| 13 | TAPF | Terminal Address Parity Fail Interrupt |
| 12 | BITF | BIT Fail Interrupt |
| 11 | MERR | Message Error Interrupt |
| 10 | SUBAD | Subaddress Accessed Interrupt |
| 9 | BDRCV | Broadcast Command Received Interrupt |
| 8 | IXEQ0 | Index Equal Zero Interrupt |
| 7 | ILLCMD | Illegal Command Interrupt |
| 6-0 | N/A | Not Applicable+ |

2.1.5 Pending Interrupt Register (Read-only) - Register 4

The Pending Interrupt Register contains information that identifies events that generate interrupts. The assertion of any bit in this register asserts an output pin, $\overline{\text{MSG_INT}}$ or $\overline{\text{YF_INT}}$ (three clock cycles). Writing to the most significant 4 bits of this register generates a $\overline{\text{YF_INT}}$.

| Bit Number | Mnemonic | Description |
|------------|----------|---|
| 15 | DMAF | DMA Fail Interrupt. Once the S μ MMIT issues the $\overline{\text{DMAR}}$ signal, an internal timer starts. If all DMA activity (which includes $\overline{\text{DMAR}}$ to $\overline{\text{DMAG}}$, and all wait states) is not completed by the time the counter decrements to zero, the interrupt is generated. In the SRT mode, the $\overline{\text{YF_INT}}$ interrupt is generated (if not masked), current command processing ends, and the SRT will remain on-line. Current cycle terminated, bus released. |
| 14 | WRAPF | Wrap Fail Interrupt. The SRT automatically compares the transmitted word (encoder word) to the reflected decoder word via the continuous loop-back feature. If the encoder word and reflected word do not match, the WRAPF bit is asserted in the BIT Word Register and a $\overline{\text{YF_INT}}$ interrupt is generated (if not masked). The loop-back path is via the MIL-STD-1553 bus transceiver. |
| 13 | TAPF | Terminal Address Parity Fail Interrupt. This bit reflects the outcome of the remote terminal address parity check. A logic one indicates a parity failure. When a parity error occurs, the SRT does not begin operation (STEX bit forced to logic zero), channel A and B do not enable, the TAPF bit is asserted here and in the BIT Word Register, and a $\overline{\text{YF_INT}}$ interrupt is generated (if not masked). |
| 12 | BITF | BIT Fail Interrupt. Assertion of this bit indicates a BIT failure. Status word bit 19 is automatically set to a logic one when a BIT failure occurs. If a BIT fails, the BITF bit is asserted here and in the BIT Word Register, and a $\overline{\text{YF_INT}}$ interrupt is generated (if not masked). Operation continues. |
| 11 | MERR | Message Error Interrupt. Assertion of this bit indicates that a message error condition exists. The SRT can detect Manchester errors, sync-field, word count errors (too many or too few), MIL-STD-1553 word parity errors, bit count errors (too many or too few), and protocol errors. If not masked, this bit is always set when the SRT asserts bit 9 of the status word (e.g., illegal commands, invalid data word, etc.). $\overline{\text{MSG_INT}}$ interrupt generated (if not masked). |
| 10 | SUBAD | Subaddress Accessed Interrupt. Assertion of this bit indicates a pre-selected subaddress has transacted a message. To determine the exact subaddress, the host interrogates the interrupt log IAW. $\overline{\text{MSG_INT}}$ interrupt generated (if not masked). |
| 9 | BDRCV | Broadcast Command Received Interrupt. This bit is set to a logic one to indicate the SRT's receipt of a valid broadcast command. The SRT suppresses status word transmission. $\overline{\text{MSG_INT}}$ interrupt generated (if not masked). |
| 8 | IXEQ0 | Index Equal Zero Interrupt. The SRT asserts this bit to indicate the completion of a pre-defined number of commands by the SRT. Upon assertion of this interrupt, the host or subsystem updates the subaddress descriptor to prevent the potential loss of data. $\overline{\text{MSG_INT}}$ interrupt generated (if not masked). |
| 7 | ILLCMD | Illegal Command Interrupt. This bit is set to a logic one to indicate the reception of an illegal command by the SRT. Upon receipt of this command, the SRT responds with a status word only; Bit 9 of the status word is set to a logic one. $\overline{\text{MSG_INT}}$ interrupt generated (if not masked). |
| 6-0 | N/A | Not Applicable. |

Note: The user must read or write a S μ MMIT register after reading the Pending Register to invoke the automatic clear of the Pending Interrupt Register. For example, a Subaddress Access interrupt results in a Pending Interrupt Register of 0400₁₆. A read of the Pending Interrupt Register returns a value of 0400₁₆. A subsequent read of the Interrupt Mask Register (i.e., Register 3), followed by a Pending Interrupt Register read returns a value of 0000₁₆. The intervening read of the Interrupt Mask Register clears the Pending Interrupt Register at the end of the Interrupt Mask Register read.

2.1.6 Interrupt Log List Pointer Register (Read/Write) - Register 5

The Interrupt Log List Pointer indicates the starting address of the Interrupt Log List. The Interrupt Log List is a 32 word ring-buffer that contains information pertinent to the service of interrupts. The S μ MMIT architecture requires the location of the Interrupt Log List on a 32-word boundary. The most significant 11 bits of this register designate the location of the Interrupt Log List within a 64K memory space. The lower 5 bits of this register should be initialized to a logic zero. The S μ MMIT controls the lower 5 bits to implement the ring-buffer architecture. The host or subsystem reads this register to determine the location and number of interrupts within the Interrupt Log List (least significant 5 bits).

Note: Bits 15-5 indicate the starting Base address while bits 4-0 indicate the ring location of the Interrupt Log List. See section 6.0 for a description of the Interrupt Architecture.

| Bit Number | Mnemonic | Description |
|------------|------------|--|
| 15-0 | INTA(15:0) | Interrupt Log List Pointer Bits. (Bit 15 MSB - Bit 0 LSB). |

2.1.7 BIT Word Register (Read/Write) - Register 6

This register contains information on the SRT's current health. The SRT transmits the contents of this register upon reception of a Transmit Bit Word Mode Code. The lower 8 bits of this register are user-defined.

| Bit Number | Mnemonic | Description |
|------------|----------|--|
| 15 | DMAF | DMA Fail. This bit is set if all DMA activity is not completed between the time $\overline{\text{DMAR}}$ asserts and when the timer decrements to zero. The DMA activity includes $\overline{\text{DMAR}}$ to $\overline{\text{DMAG}}$ and all wait states. In the event of a DMA failure, current message processing terminates; remote terminal waits for next 1553 message. DMAF asserts, and $\overline{\text{YF_INT}}$ is generated (if not masked). |
| 14 | WRAPF | Wrap Fail. The SRT automatically compares the transmitted word (encoder word) to the reflected decoder word via the continuous loop-back feature. If the encoder word and reflected word do not match, the WRAPF bit asserts and a $\overline{\text{YF_INT}}$ interrupt is generated (if not masked). The loop-back path is via the MIL-STD-1553 bus transceiver. A wrap failure does not result in the terminal flag bit being set to a logical one. Message processing continues. |
| 13 | TAPF | Terminal Address Parity Fail. This bit reflects the outcome of the remote terminal address parity check. A logic one indicates a parity failure. When a parity error occurs the SRT does not begin operation (STEX bit forced to a logic zero), channel A and B do not enable, and a $\overline{\text{YF_INT}}$ interrupt is generated (if not masked). |
| 12 | BITF | BIT Fail. Assertion of this bit indicates a BIT failure. Bits 11 through 8 should be interrogated to determine the specific failure. Status word bit 19 is automatically set to a logic one when a BIT failure occurs. If a BIT fails, the BITF bit is asserted, and a $\overline{\text{YF_INT}}$ interrupt is generated (if not masked). Operation continues. |
| 11 | CHAF | Channel A Fail. Assertion of this bit indicates a BIT test failure in Channel A. |
| 10 | CHBF | Channel B Fail. Assertion of this bit indicates a BIT test failure in Channel B. |
| 9 | MSBF/UDB | Memory Test Fail. Most significant memory byte failure (S μ MMIT XTE). User-Defined Bits (S μ MMIT E & S μ MMIT LXE/DXE). |
| 8 | LSBF/UDB | Memory Test Fail. Least significant memory byte failure (S μ MMIT XTE). User-Defined Bits (S μ MMIT E & S μ MMIT LXE/DXE). |
| 7-0 | UDB(7:0) | User-Defined Bits. |

2.1.8 Time-Tag Register (Read/Write) - Register 7

The Time-Tag Register reflects the state of a 16-bit free running counter. The resolution of this counter is user-defined via input TCLK or fixed at 64μs/bit. The Time-Tag counter is automatically reset when the SRT receives a valid synchronize without data mode code. The SRT automatically loads the Time-Tag counter with the data associated with reception of a valid synchronize with data mode code. The Time-Tag counter begins operation on the rising edge of \overline{MRST} or within 64μs after the receipt of a valid Reset Remote Terminal Mode Code, Synchronize with Data Mode Code, or Synchronize without Data Mode Code. When the SRT is halted (STEX = 0), the Time-Tag continues to run. Time-Tag value is captured upon command word-validation.

| Bit Number | Mnemonic | Description |
|-------------------|-----------------|---|
| 15-0 | TT(15:0) | Time-Tag Counter Bits. (Bit 15 MSB - Bit 0 LSB) |

2.1.9 Remote Terminal Descriptor Pointer Register (Read/Write) - Register 8

The SRT accesses a block of external memory to gain information on how to process a valid command. Each subaddress and mode code has a block of memory reserved for this task. Located contiguously in memory, these reserved memory locations are called a descriptor space. The Remote Terminal Descriptor Pointer Register contains an address that points to the top of this memory space. The SRT uses the T/\overline{R} bit, subaddress/mode code field, and mode code to select one block within the descriptor table for message processing. The Remote Terminal Descriptor Pointer Register is static during message processing.

| Bit Number | Mnemonic | Description |
|-------------------|-----------------|---|
| 15-0 | RTDA(15:0) | Remote Terminal Descriptor Address Bits. (Bit 15 MSB - Bit 0 LSB) |

2.1.10 1553 Status Word Bits Register (Read/Write) - Register 9

The host or subsystem accesses this register to control the outgoing MIL-STD-1553 status word. The host or subsystem controls the Instrumentation, Busy, Terminal Flag, Service Request, and Subsystem Flag by writing to bits 9 through 0 of this register. The SRT's status word response reflects assertion of these bit(s) until negated by the host or subsystem unless the Immediate Clear Function is enabled. The Immediate Clear Function automatically clears these bits after being transmitted in a status word.

The Immediate Clear Function does not affect the operation of the Transmit Status word and Transmit Last Command word Mode Codes. Transaction of a legal valid command with the INS bit set to a logic one and the Immediate Clear Function enabled, results in the transmission of a status word with Bit 10 asserted. If the ensuing command is a Transmit Status word or Last Command mode code, Bit 10 of the outgoing status word remains a logic one. For MIL-STD-1553B applications, the register is as follows:

| Bit Number | Mnemonic | Description |
|------------|----------|--|
| 15 | IMCLR | Immediate Clear Function. Assertion of this bit enables the Immediate Clear Function (IMF) of the SRT. Enabling the IMF results in the clearing of the INS, BUSY, TF, SRQ, and/or SUBF bit immediately after a message is completed. This function is enabled by asserting this bit when asserting bit(s) INS, BUSY, TF, SRQ, and/or SSYSF. This bit should be used consistently since once set, it will remain set, and once cleared, it will remain cleared. |
| 14-10 | N/A | Not Applicable. |
| 9 | INS | Instrumentation Bit. This bit asserts the Instrumentation bit of the MIL-STD-1553B status word. (Bit 10 of the Status Word). |
| 8 | SRQ | Service Request Bit. This bit asserts the Service Request bit of the MIL-STD-1553B status word. (Bit 11 of the Status Word). |
| 7-4 | N/A | Not Applicable. |
| 3 | BUSY | Busy Bit. Assertion of this bit is reflected in the outgoing MIL-STD-1553B status word. Assertion of this bit prevents memory accesses. (Bit 16 of the Status Word). |
| 2 | SSYSF | Subsystem Flag Bit. This bit asserts the Subsystem Flag bit of the MIL-STD-1553B status word and may also be set with the SSYSF input pin. (Bit 17 of the Status Word). |
| 1 | N/A | Not Applicable. |
| 0 | TF | Terminal Flag. Assertion of this bit is reflected in the outgoing MIL-STD-1553B status word. The SRT automatically asserts this bit if a BIT failure occurs. Inhibit Terminal Flag mode code prevents the assertion by the host or subsystem. Override Inhibit Terminal Flag Mode Code re-establishes the Terminal Flag option (Bit 19 of the Status Word). |

For MIL-STD-1553A applications, the register is as follows:

| Bit Number | Mnemonic | Description |
|-------------------|-----------------|--|
| 15 | IMCLR | Immediate Clear Function. Assertion of this bit enables the Immediate Clear Function (IMF) of the SRT. Enabling the IMF results in the clearing of the bit times 10-19 immediately after a status word is transmitted. This function is enabled by asserting this bit when asserting bit times 10-19. This bit should be used consistently since once set, it will remain set, and once cleared, it will remain cleared. |
| 14-10 | N/A | Not Applicable. |
| 9 | SB10 | Status bit time 10. |
| 8 | SB11 | Status bit time 11. |
| 7 | SB12 | Status bit time 12. |
| 6 | SB13 | Status bit time 13. |
| 5 | SB14 | Status bit time 14. |
| 4 | SB15 | Status bit time 15. |
| 3 | SB16 | Status bit time 16. |
| 2 | SB17 | Status bit time 17. |
| 1 | SB18 | Status bit time 18. |
| 0 | SB19 | Status bit time 19. |

2.1.11 Illegalization Registers

The 16 registers are divided into 8 blocks, 2 registers per block (see table 1).

Table 1. Illegalization Register Blocks

| Block Name | Address (hex) |
|--|----------------------|
| Receive | 0010 and 0011 |
| Transmit | 0012 and 0013 |
| Broadcast Receive | 0014 and 0015 |
| Broadcast Transmit (Automatically Illegalized) | 0016 and 0017 |
| Mode Code Receive | 0018 and 0019 |
| Mode Code Transmit | 001A and 001B |
| Broadcast Mode Code Receive | 001C and 001D |
| Broadcast Mode Code Transmit | 001E and 001F |

The blocks correspond to the following types of commands. Register address 0010 (hex) and 0011 (hex) illegalize receive commands to 32 subaddresses. The most significant bit of register 0010 (hex) controls the illegalization of subaddress 01111. The least significant bit controls subaddress 00000. Register 0011 (hex) controls illegalization of subaddresses 10000 through 11111. The least significant bit relates to subaddress 10000; the most significant bit relates to subaddress 11111. Transmit commands and broadcast commands (both receive and transmit) use the same encoding scheme as receive subaddress illegalization.

Registers 18 (hex) through 1F (hex) control the illegalization of mode codes. Register 18 governs the illegalization of receive mode codes (T/\bar{R} bit = 0) 00000 through 01111 and register 19 mode codes 10000 through 11111. Register blocks Transmit Mode Code (T/\bar{R} bit = 1), Broadcast Receive Mode Codes, and Broadcast Transmit Mode Codes use the same decode scheme as receive mode codes.

Table 2 shows the illegalization register map. For each block, the numbers shown in the column under each bit number identifies the specific subaddress or mode code (in hex) that the register bit illegalizes (Logical 0 = legal, Logical 1 = illegal).

Table 2. Illegalization Register Map

| Name | Register Number | 15 | 14 | 13 | 12 | 11 | 10 | 9 | 8 | 7 | 6 | 5 | 4 | 3 | 2 | 1 | 0 |
|-------------------|-----------------|----|----|----|----|----|----|----|----|----|----|----|----|----|----|----|----|
| Receive | 16 | 0F | 0E | 0D | 0C | 0B | 0A | 09 | 08 | 07 | 06 | 05 | 04 | 03 | 02 | 01 | 00 |
| | 17 | 1F | 1E | 1D | 1C | 1B | 1A | 19 | 18 | 17 | 16 | 15 | 14 | 13 | 12 | 11 | 10 |
| Transmit | 18 | 0F | 0E | 0D | 0C | 0B | 0A | 09 | 08 | 07 | 06 | 05 | 04 | 03 | 02 | 01 | 00 |
| | 19 | 1F | 1E | 1D | 1C | 1B | 1A | 19 | 18 | 17 | 16 | 15 | 14 | 13 | 12 | 11 | 10 |
| Brd Receive | 20 | 0F | 0E | 0D | 0C | 0B | 0A | 09 | 08 | 07 | 06 | 05 | 04 | 03 | 02 | 01 | 00 |
| | 21 | 1F | 1E | 1D | 1C | 1B | 1A | 19 | 18 | 17 | 16 | 15 | 14 | 13 | 12 | 11 | 10 |
| Brd Transmit | 22 | XX | XX | XX | XX | XX | XX | XX | XX | XX | XX | XX | XX | XX | XX | XX | XX |
| | 23 | XX | XX | XX | XX | XX | XX | XX | XX | XX | XX | XX | XX | XX | XX | XX | XX |
| Mode Receive | 24 | 0F | 0E | 0D | 0C | 0B | 0A | 09 | 08 | 07 | 06 | 05 | 04 | 03 | 02 | 01 | 00 |
| | 25 | 1F | 1E | 1D | 1C | 1B | 1A | 19 | 18 | 17 | 16 | 15 | 14 | 13 | 12 | 11 | 10 |
| Mode Transmit | 26 | 0F | 0E | 0D | 0C | 0B | 0A | 09 | 08 | 07 | 06 | 05 | 04 | 03 | 02 | 01 | 00 |
| | 27 | 1F | 1E | 1D | 1C | 1B | 1A | 19 | 18 | 17 | 16 | 15 | 14 | 13 | 12 | 11 | 10 |
| Mode Brd Receive | 28 | 0F | 0E | 0D | 0C | 0B | 0A | 09 | 08 | 07 | 06 | 05 | 04 | 03 | UU | 01 | WW |
| | 29 | 1F | 1E | 1D | 1C | 1B | 1A | 19 | 18 | 17 | 16 | 15 | 14 | 13 | 12 | 11 | 10 |
| Mode Brd Transmit | 30 | 0F | 0E | 0D | 0C | 0B | 0A | 09 | 08 | 07 | 06 | 05 | 04 | 03 | ZZ | 01 | XX |
| | 31 | YY | YY | YY | YY | YY | YY | YY | YY | YY | YY | YY | YY | YY | YY | YY | YY |

Notes:

1. Brd = Broadcast.
2. Mode = Mode code.
3. XX= Automatically illegalized by SRT.
4. YY= Automatically illegalized by SRT in 1553B only.
5. ZZ= Automatically illegalized by SRT in 1553B and 1553A if XMTSW is enabled.
6. WW = Automatically illegalized in 1553A.
7. UU = Automatically illegalized in 1553A if XMTSW enabled.

2.2 Descriptor Block

To process messages, the SRT uses data supplied in the internal registers with data stored in external memory. The SRT accesses a four word descriptor block stored in external memory. The descriptor block is accessed at the beginning and end of command processing. Multiple descriptor blocks are sequentially entered into memory to form a descriptor table. The following paragraphs discuss the descriptor block in detail.

The host or subsystem controlling the SRT allocates 512 consecutive memory spaces for the subaddress and mode code descriptor table. The top of the descriptor table can reside at any address location. Defined and entered into memory by the host, the SRT is linked to the descriptor table via the Descriptor Address Register contents (see figures 4a and 4b). Each descriptor block contains a Control Word, Data Pointer A, Data Pointer B, and Broadcast Data Pointer. Each subaddress and mode code is assigned a descriptor for receive and transmit commands (T/\bar{R} bit equal zero or one).

Control word information allows the SRT to generate interrupts, buffer messages, and control message processing. For a receive command, the Data Pointer is read to determine the top of the data buffer. The SRT stores data sequentially from the top of data buffer plus two locations (e.g., 0100, 0101, 0102, 0103, etc.). When processing a transmit command, the Data Pointer is read to determine where data words are retrieved. The SRT retrieves data words sequentially from the address the Data Pointer designates plus two address locations.

The Broadcast Data Pointer allows for separate storage of non-broadcast data from broadcast data per MIL-STD-1553B Notice II. The host or subsystem enables or disables this feature via the Control Word's least significant bit. When disabled, the non-

broadcast and broadcast data is stored via Data List Pointer A or B. For transmit commands, the Broadcast Data Pointer is not used. The SRT does not transmit any information on the receipt of a broadcast transmit command.

The SRT reads the descriptor block during command processing (i.e., after assertion of \overline{TERACT}). The SRT arbitrates for the memory bus. After receiving control of the bus, the SRT reads the control word and three Data Pointers. The SRT then surrenders control of the bus back to the bus master (i.e., negates \overline{DMACK}). The SRT then begins the acquisition of data words for either transmission or storage.

After transmission or reception, the SRT begins post-processing. Command post-processing begins with arbitration for the memory bus. The SRT performs a DMA burst during post-processing. An optional interrupt log entry is performed after a descriptor update. During the descriptor update, the SRT modifies the Control Word index field and bits 4, 2, and 1, if required. The SRT updates Data Pointer A if no message errors occurred during the message transaction. Reception of a broadcast command, with no message errors, results in the update of the Broadcast Data Pointer. Neither Data Pointer A, B or Broadcast is updated if the SRT has the ping-pong mode of operation enabled.

See section 5, Enhanced S μ MMIT Family Operation for additional information.

| T/R | Subaddress/Mode Code Descriptors | Address Equation |
|-----|----------------------------------|--|
| 0 | Subaddress | Descriptor Address Register Contents + [(SA# x 4) + 0] |
| 1 | Subaddress | Descriptor Address Register Contents + [(SA# x 4) + 128] |
| 0 | Mode Codes | Descriptor Address Register Contents + [(MC# x 4) + 256] |
| 1 | Mode Codes | Descriptor Address Register Contents + [(MC# x 4) + 384] |

Figure 4a. Descriptor Table (16-Bit Data Bus)

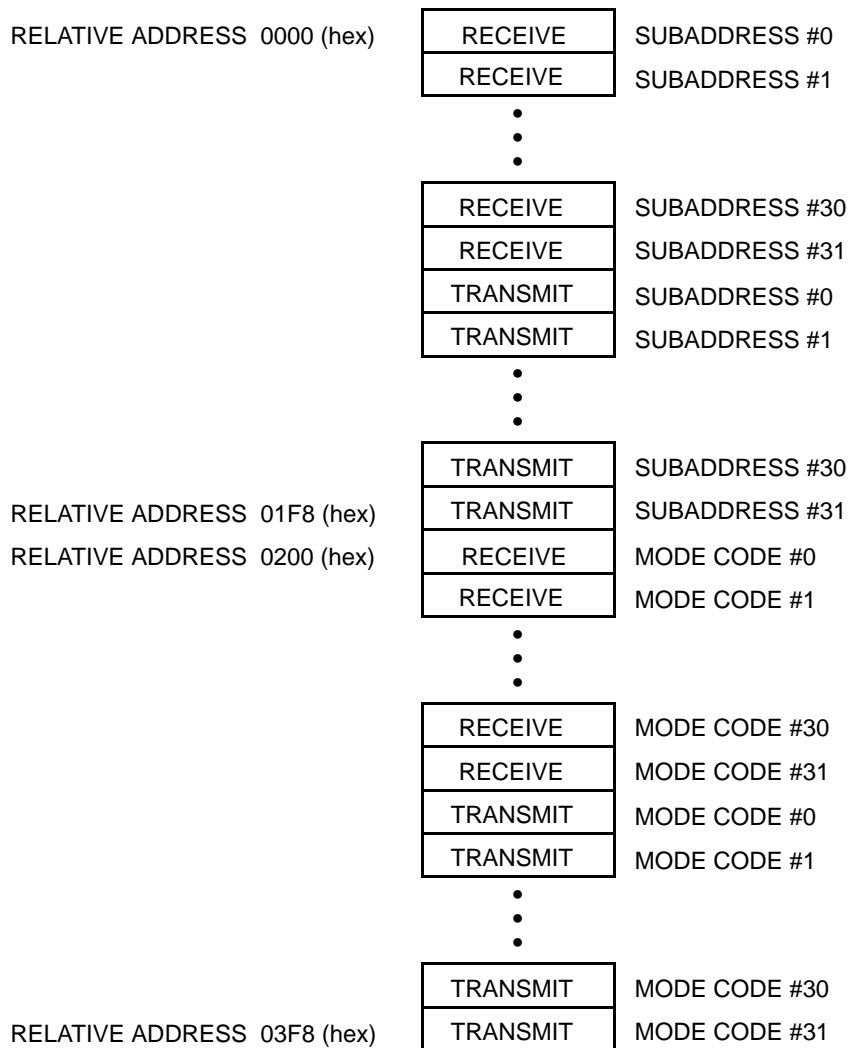

Figure 4d. Descriptor Table (8-Bit Data Bus)

2.2.1 Receive Control Word

The following bits describe the receive subaddress Descriptor Control Word. Information contained in this word assists the SRT in message processing. The Descriptor Control Word is initialized by the host or subsystem and updated by the SRT during command post-processing.

| Bit Number | Mnemonic | Description |
|------------|------------------|--|
| 15-8 | INDX | Index Field. These bits define multiple message buffer length. The host or subsystem uses this field to instruct the SRT to buffer “N” messages. “N” can range from 0 (00 hex) to 255 (FF hex). If buffer ping-ponging is enabled, the INDX field is “don’t care” (i.e., does not contain applicable information). During ping-pong mode operation, initialize the index field to 00 (hex). The SRT does not perform multiple message buffering in the ping-pong mode of operation. The index decrements each time a complete message is transacted (no message errors). The index does not decrement if the subaddress is illegalized. The SRT can generate an interrupt when the index field transitions from one to zero (see bit 7). |
| 7 | INTX | Interrupt Index Equals Zero. Assertion of this bit enables the generation of an interrupt when the index field transitions from one to zero. The interrupt is <u>entered into</u> the Pending Interrupt Register if not masked in the Mask Register. Output pin $\overline{\text{MSG_INT}}$ asserts after message processing. |
| 6 | IWA | Interrupt When Accessed. Assertion of this bit enables the generation of an interrupt when the subaddress receives a valid command; this includes illegal and broadcast commands. The interrupt is <u>entered into</u> the Pending Interrupt Register if not masked in the Mask Register. Output pin $\overline{\text{MSG_INT}}$ asserts after message processing. |
| 5 | IBRD | Interrupt Broadcast Received. Assertion of this bit enables the generation of an interrupt when the subaddress receives a valid broadcast command. The interrupt is <u>entered into</u> the Pending Interrupt Register if not masked in the Mask Register. Output pin $\overline{\text{MSG_INT}}$ asserts after message processing. |
| 4 | BAC | Block Accessed. The subsystem or host initializes this bit to zero; the SRT overwrites the zero with a logic one upon completion of message processing. After interrogating this bit, the host resets this bit to zero to observe further accesses. |
| 3 | N/A | Not Applicable. |
| 2 | A/\overline{B} | Buffer A/\overline{B} . Indicates the last buffer accessed when buffer ping-pong is enabled. During initialization, the host designates the first buffer used by asserting or negating this bit. A logic one indicates buffer A; a logic zero indicates buffer B. This bit is a “don’t care” if buffer ping-ponging is not enabled. |
| 1 | BRD | Broadcast Received. Assertion of this bit indicates the reception of a valid broadcast command. |
| 0 | NII | Notice II. Assertion of this bit enables the use of the Broadcast Data Pointer as a buffer for broadcast command information. When negated, broadcast information is stored in the same buffer as non-broadcast information. |

2.2.2 Transmit Control Word

The following bits describe the transmit subaddress Descriptor Control Word. Information contained in this word assists the SRT in message processing. The Descriptor Control Word is initialized by the host or subsystem and updated by the SRT during command post-processing.

| Bit Number | Mnemonic | Description |
|------------|-------------------------|---|
| 15-7 | N/A | Not Applicable. |
| 6 | IWA | Interrupt When Accessed. Assertion of this bit enables the generation of an interrupt when the subaddress receives a valid command; his includes illegal and broadcast commands. The interrupt is entered into the Pending Interrupt Register if not masked in the Mask Register. Output pin $\overline{\text{MSG_INT}}$ asserts after message processing. |
| 5 | N/A | Not Applicable. |
| 4 | BAC | Block Accessed. The subsystem or host initializes this bit to zero, the SRT overwrites the zero with a logic one upon completion of message processing. After interrogation, the host should reset this bit to zero to observe further accesses. |
| 3 | N/A | Not Applicable. |
| 2 | A $\overline{\text{B}}$ | Buffer A $\overline{\text{B}}$. Indicates the data pointer to access when buffer ping-pong is enabled. During initialization, the host designates the first buffer used by asserting or negating this bit. A logic one indicates buffer A; a logic zero indicates buffer B. This bit is a “don’t care” if buffer ping-ponging is not enabled. |
| 1 | BRD | Broadcast Received. Assertion of this bit indicates the reception of a broadcast command. |
| 0 | N/A | Not Applicable. |

2.2.3 Mode Code Receive Control Word

The following bits describe the receive mode code Descriptor Control Word. Information contained in this word assists the SRT in message processing. The Descriptor Control Word is initialized by the host or subsystem and updated by the SRT during command post-processing.

Note: In MIL-STD-1553A, all mode codes are without data, and the T/\bar{R} bit is ignored. See section 2.9 for the MIL-STD-1553A operation.

| Bit Number | Mnemonic | Description |
|------------|-------------|--|
| 15-8 | INDX | Index Field. These bits define message buffer length. The host or subsystem uses this field to instruct the SRT to buffer “N” messages. “N” can range from 0 (00 hex) to 256 (FF hex). If buffer ping-ponging is enabled, the INDX field is “don’t care” (i.e., does not contain applicable information). The SRT does not perform message buffering in the ping-pong mode of operation. The index decrements each time a complete message is transacted (no message errors). The index does not decrement if the mode code is illegalized. The SRT can generate an interrupt when the index field transitions from one to zero (see bit 7). |
| 7 | INTX | Interrupt Index Equals Zero. Assertion of this bit enables the generation of an interrupt when the index field transitions from one to zero. The interrupt is entered into the Pending Interrupt Register if not masked in the Mask Register. Output pin $\overline{\text{MSG_INT}}$ asserts after message processing. |
| 6 | IWA | Interrupt When Accessed. Assertion of this bit enables the generation of an interrupt when mode code command is received; this includes illegal and broadcast commands. The interrupt is entered into the Pending Interrupt Register if not masked in the Mask Register. Output pin $\overline{\text{MSG_INT}}$ asserts after message processing. |
| 5 | IBRD | Interrupt Broadcast Received. Assertion of this bit enables the generation of an interrupt when a valid broadcast mode code command is received. The interrupt is entered into the Pending Interrupt Register if not masked in the Mask Register. Output pin $\overline{\text{MSG_INT}}$ asserts after message processing. |
| 4 | BAC | Block Accessed. The subsystem or host initializes this bit to zero; the SRT overwrites the zero with a logic one upon completion of message processing. After interrogating this bit, the host resets this bit to zero to observe further accesses. |
| 3 | N/A | Not Applicable. |
| 2 | A/\bar{B} | Buffer A/\bar{B} . Indicates the last buffer accessed when buffer ping-pong is enabled. During initialization, the host designates the first buffer used by asserting or negating this bit. A logic one indicates buffer A; logic zero indicates buffer B. This bit is a “don’t care” if buffer ping-ponging is not enabled. |
| 1 | BRD | Broadcast Received. Assertion of this bit indicates the reception of a valid broadcast command. |
| 0 | NII | Notice II. Asserting this bit enables the use of the Broadcast Data Pointer as a buffer for broadcast command information. When negated, broadcast information is stored in the same buffer as non-broadcast information. |

2.2.4 Mode Code Transmit Control Word

The following bits describe the transmit mode code Descriptor Control Word. Information contained in this word assists the SRT in message processing. The Descriptor Control Word is initialized by the host or subsystem and updated by the SRT during command post-processing.

Note: In MIL-STD-1553A, all mode codes are without data, and the T/\bar{R} bit is ignored. See section 2.9 for the MIL-STD-1553A operation.

| Bit Number | Mnemonic | Description |
|------------|-------------|---|
| 15-7 | N/A | Not Applicable. |
| 6 | IWA | Interrupt When Accessed. Assertion of this bit enables the generation of an interrupt when mode code command is received; this includes illegal and broadcast commands. The interrupt is entered into the Pending Interrupt Register if not masked in the Mask Register. Output pin $\overline{MSG_INT}$ asserts after message processing. |
| 5 | IBRD | Interrupt Broadcast Received. Assertion of this bit enables the generation of an interrupt when a valid broadcast mode code is received. The interrupt is entered into the Pending Interrupt Register if not masked in the Mask Register. Output pin $\overline{MSG_INT}$ asserts after message processing. |
| 4 | BAC | Block Accessed. The subsystem or host initializes this bit to zero; the SRT overwrites the zero with a logic one upon completion of message processing. After interrogating this bit, the host resets this bit to zero to observe further accesses. |
| 3 | N/A | Not Applicable. |
| 2 | A/\bar{B} | Buffer A/\bar{B} . This bit indicates the last buffer accessed when buffer ping-pong is enabled. During initialization, the host designates the first buffer used by asserting or negating this bit. A logic one indicates buffer A; a logic zero indicates buffer B. This bit is a “don’t care” if buffer ping-ponging is not enabled. |
| 1 | BRD | Broadcast Received. Assertion of this bit indicates the reception of a broadcast command. |
| 0 | N/A | Not Applicable. |

2.2.5 Data Pointer A and B

Data Pointer A and B contain address information for the retrieval and storage of message data words. In the index mode of operation, the SRT reads Data Pointer A to determine the location of data for retrieval or storage. The SRT uses the Data Pointer to initialize an internal counter; the counter increments after each data word. For a receive command, the SRT stores the incoming data word sequentially into memory. As part of command post-processing, the SRT writes a new data pointer into the descriptor block. The SRT continues to update the data pointer until the Control Word index field decrements to zero. An example is shown in figure 5.

Note: The index feature is not applicable for transmit commands (i.e., T/\bar{R} bit = 1).

For ping-pong buffer operation, the host uses either Data Pointer A or Data Pointer B. The SRT determines which pointer to access via the state of Control Word bit 2. The SRT retrieves or stores data words from the address contained in the data pointer, automatically incrementing the data pointer as data words are received. The data pointer is never updated as part of command post-processing in the ping-pong mode of operation. See figures 6 and 7.

| Bit Number | Mnemonic | Description |
|------------|----------|---|
| 15-0 | DP(15:0) | Data Pointer Bits. The second and third words of the descriptor block contain the data buffer location. The SRT accesses either Data Pointer A or Data Pointer B depending on the state of Control Word Bit 2 during ping-pong operation. For index operation, the SRT accesses only Data Pointer A. The SRT updates Data Pointer A after message processing is complete and the index field is not equal to zero and ping-pong operation disabled. Bit 15 is the most significant bit; bit 0 is the least significant bit. |

2.2.6 Broadcast Data Pointer

The following bits describe the receive subaddress/mode code descriptor Broadcast Data Pointer. This word contains the address for the Message Information word, Time-Tag word, and data words associated with a broadcast command. The SRT automatically increments this data pointer during command post-processing, if ping-pong operation disabled.

| Bit Number | Mnemonic | Description |
|------------|----------|--|
| 15-0 | BP(15:0) | Broadcast Data Pointer. The fourth word of the descriptor block contains the broadcast data buffer location. This pointer can reside anywhere inside of a 64K data space. The SRT accesses this pointer when Control Word bit 0 is a logic one and broadcast is enabled. Bit 15 is the most significant bit; bit 0 is the least significant bit. Note: If ping-pong is enabled, this pointer does not update. Note: When the broadcast command is followed by a Transmit Last Command or Transmit Status Word mode code, the SRT transmits a status word with bit 15 of the status word set to a logic one. The broadcast bit is cleared by reception of the next valid non-broadcast command. |

2.3 Data Structures

The following sections discuss the data structures that result from command processing. For each complete message processed, the SRT generates a Message Information word and Time-Tag word. These words aid the host or subsystem

in further message processing. The Message Information word contains word count, message type, and message error information. The Time-Tag word is a 16-bit word containing the command validity time. The Time-Tag word data comes from the SRT's internal Time-Tag counter.

See section 5, Enhanced Family S μ MMIT Operation for additional data structure information

Receive Subaddress #1
Descriptor Block

| |
|----------------|
| CONTROL WORD |
| DATA POINTER A |
| DATA POINTER B |
| BROADCAST |

Index field contents: 02XX (hex)
Data Pointer A: 0100 (hex)
Data Pointer B: XXXX (hex)
Broadcast Data Pointer: XXXX (hex)

Command #1
Receive three words

| |
|-------------------|
| Message Info Word |
| Time-Tag |
| Data Word #1 |
| Data Word #2 |
| Data Word #3 |

0100 (hex) Index equals two
0101 (hex)
0102 (hex)
0103 (hex)
0104 (hex) Index decrements to one

Command #2
Receive two words

| |
|-------------------|
| Message Info Word |
| Time-Tag |
| Data Word #1 |
| Data Word #2 |

0105 (hex) Index equals one
0106 (hex)
0107 (hex)
0108 (hex) Index decrements to zero
(interrupt generated if enabled)

Command #3
Receive three words

| |
|-------------------|
| Message Info Word |
| Time-Tag |
| Data Word #1 |
| Data Word #2 |
| Data Word #3 |

0109 (hex) Index equals zero
010A (hex)
010B (hex)
010C (hex)
010D (hex) Index remains zero
(Data Pointer A = 109)

Note:
x = "don't care"

Figure 5. Non-Broadcast Receive Message Indexing

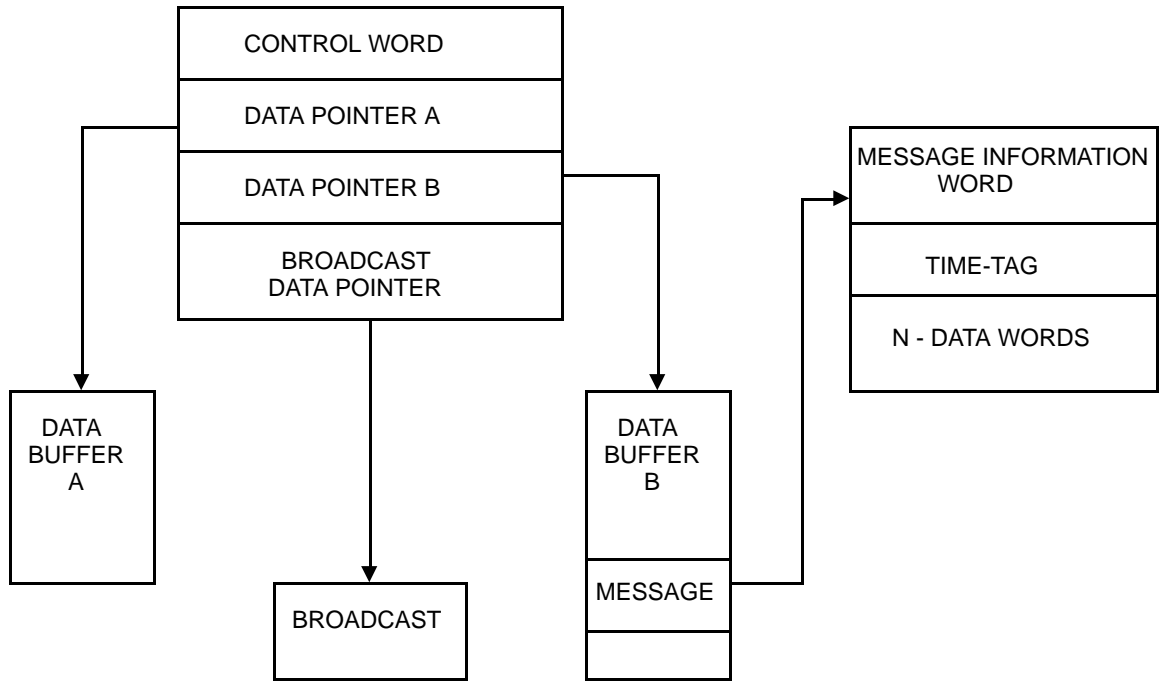

**Figure 6. SRT Descriptor Block
(Receive)**

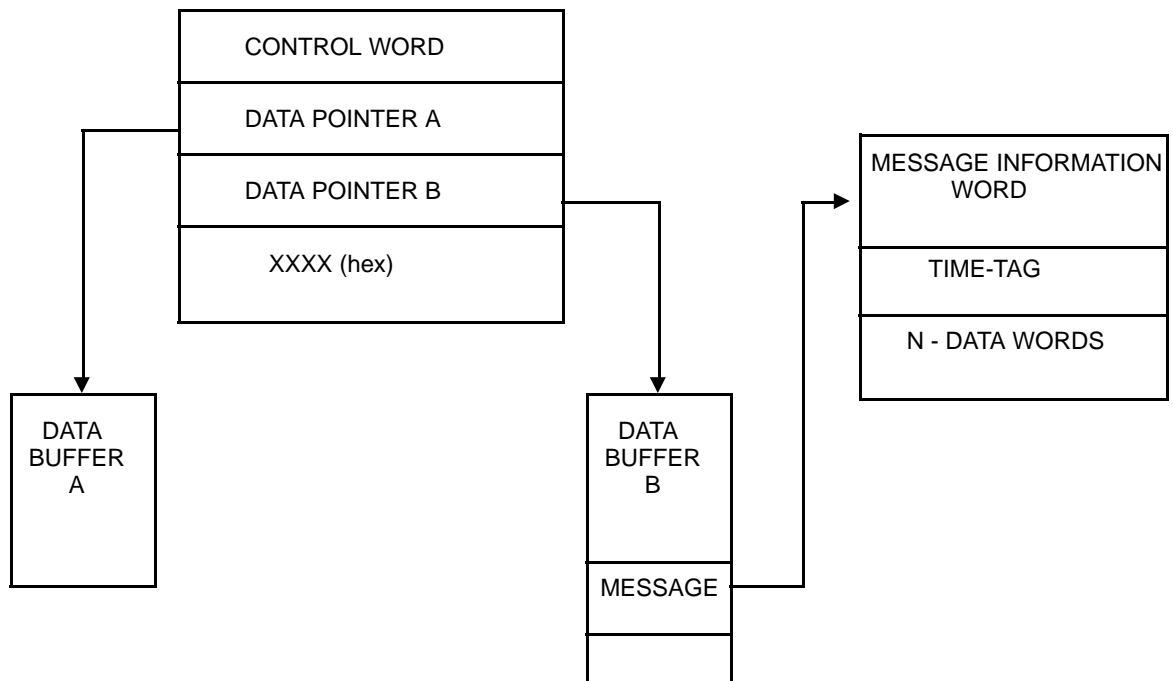

**Figure 7. SRT Descriptor Block
(Transmit)**

2.3.1 Subaddress Receive Data

For receive commands, the SRT stores data words plus two additional words. The SRT adds a Receive Information word and Time-Tag word to each receive command data packet. The SRT places the Receive Information word and Time-Tag word ahead of the data words associated with a receive command (see figures 5, 6 and 7). When message errors occur, the SRT enters the Receive Information word, and Time-Tag word. Once a message error condition is observed, all data words are considered invalid.

Data storage occurs at the memory location pointed to by the data pointer plus two locations.

2.3.1.1 Receive Information (Info) Word

The following bits describe the Receive Information Word contents.

| Bit Number | Mnemonic | Description |
|------------|----------------|--|
| 15-11 | WC(4:0) | Word Count Bits. These five bits contain word count information extracted from the transmit command word bits 15 to 19. |
| 10 | N/A | Not Applicable. |
| 9 | CHA/ \bar{B} | Channel A/ \bar{B} . Assertion of this bit indicates that the message was received on channel A. Conversely, if this bit is set to logic zero, the message was received on channel B. |
| 8 | RTRT | Remote Terminal to Remote Terminal transfer. The command processed was a RT-to-RT transfer. |
| 7 | ME | Message Error. Assertion of this bit indicates a message error condition was observed during processing. See bits 0 to 4 for details. |
| 6-5 | N/A | Not Applicable. |
| 4 | ILL | Illegal Command Received. Assertion of this bit indicates the command received was an illegal command. |
| 3 | TO | Time-Out Error. Assertion of this bit indicates the SRT did not receive the proper number of data words, i.e., the number of data words received was less than the word count specified in the command word. |
| 2 | OVR | Overrun Error. Assertion of this bit indicates the SRT received a word when none was expected or the number of data words received was greater than expected. |
| 1 | PRTY | Parity Error. Assertion of this bit indicates the SRT observed a parity error in the incoming data words. |
| 0 | MAN | Manchester Error. Assertion of this bit indicates the SRT observed a Manchester error in the incoming data words. |

2.3.2 Subaddress Transmit Data

The host or subsystem is responsible for organization of the data packet (i.e., N data words) into memory and establishing the applicable data pointer. The host or subsystem allocates two memory locations at the top of the data packet for the storage of the Transmit Information word and Time-Tag word. An example transmit data structure for three words is shown below.

| | | | |
|----------------------|------------|------|----------------------------------|
| Data Pointer A ----> | 0100 (hex) | XXXX | ;reserved for Transmit Info word |
| equals 0100 (hex) | 0101 (hex) | XXXX | ;reserved for Time-Tag word |
| | 0102 (hex) | FFFF | ;data word |
| | 0103 (hex) | FFFF | ;data word |
| | 0104 (hex) | FFFF | ;data word |

Note: Data Pointer A points to the top of the data structure not to the top of the data words.

2.3.2.1 Transmit Information (Info) Word

The following bits describe the Transmit Information word contents.

| Bit Number | Mnemonic | Description |
|------------|----------------|---|
| 15-11 | WC(4:0) | Word Count Bits. These five bits contain word count information extracted from the receive command word bits 15 to 19. |
| 10 | N/A | Not Applicable. |
| 9 | CHA/ \bar{B} | Channel A/ \bar{B} . Assertion of this bit indicates that the message was received on the A bus. Conversely, if this bit is set to logic zero, the message was received on the B bus. |
| 8 | N/A | Not Applicable. |
| 7 | ME | Message Error. Assertion of this bit indicates a message error condition was observed during processing. See bits 0 to 4 for more detail. |
| 6-5 | N/A | Not Applicable. |
| 4 | ILL | Illegal Command Received. Assertion of this bit indicates the command received was an illegal command. |
| 3 | N/A | Not Applicable. |
| 2 | OVR | Overrun Error. Assertion of this bit indicates the SRT received a data word with a Transmit Command. |
| 1-0 | N/A | Not Applicable. |

2.3.3 Mode Code Data

The transmit and receive data structures for mode codes are similar to those for subaddress. The receive data structure contains an Information word, Time-Tag word, and message data word. All receive mode codes with data have one associated data word. Data storage occurs at the memory location pointed to by the data pointer plus two locations. Reception of the synchronize with data mode code automatically loads the Time-Tag counter and stores the data word at the address defined by the data pointer plus two locations.

The transmit mode code data structure contains an Information word, Time-Tag word, and associated data word. The subsystem or host is responsible for linking the SRT Data Pointer to the data (e.g., Transmit Vector word). For mode codes with internally generated data words (e.g., Transmit BIT word, Transmit Last Command), the transmitted data word is added to the data structure.

For MIL-STD-1553A mode of operation, all mode codes are defined without data words. For mode codes without data, the data structure contains the Message Information word and Time-Tag word only.

Note: In MIL-STD-1553A, all mode codes are without data and the T/ \bar{R} bit is ignored. See section 2.9 for the MIL-STD-1553A operation.

2.3.3.1 *Mode Code Receive Information (Info) Word.* The following bits describe the Mode Code Receive Information word contents.

| Bit Number | Mnemonic | Description |
|------------|----------------|--|
| 15-11 | MC (4:0) | Mode Code. These five bits contain the mode code information extracted from the receive command word bits 15 to 19. |
| 10 | N/A | Not Applicable. |
| 9 | CHA/ \bar{B} | Channel A/ \bar{B} . Assertion of this bit indicates that the message was received on the A bus. Conversely, if this bit is set to logic zero, the message was received on the B bus. |
| 8 | RTRT | Remote Terminal to Remote Terminal transfer. Assertion of this bit indicates the command processed was a RT-to-RT transfer. |
| 7 | ME | Message Error. Assertion of this bit indicates a message error condition was observed during processing. See bits 0 to 4 for details. |
| 6-5 | N/A | Not Applicable. |
| 4 | ILL | Illegal Command Received. Assertion of this bit indicates the command received was an illegal command. |
| 3 | TO | Time-out Error. Assertion of this bit indicates the SRT did not receive the proper number of data words, i.e., the number of data words received was less than the word count specified in the command word. |
| 2 | OVR | Overrun Error. Assertion of this bit indicates the SRT received a word when none was expected, or the number of data words received was greater than expected. |
| 1 | PRTY | Parity Error. Assertion of this bit indicates the SRT observed a parity error in the incoming data words. |
| 0 | MAN | Manchester Error. Assertion of this bit indicates the SRT observed a Manchester error in the incoming data words. |

2.3.3.2 *Mode Code Transmit Information (Info) Word.* The following bits describe the Mode Code Transmit Information word contents.

| Bit Number | Mnemonic | Description |
|------------|----------------|---|
| 15-11 | MC (4:0) | Mode Code. These five bits contain the mode code information extracted from the command word bits 15 to 19. |
| 10 | N/A | Not Applicable. |
| 9 | CHA/ \bar{B} | Channel A/ \bar{B} . Assertion of this bit indicates that the message was received on the A bus. Conversely, if this bit is set to logic zero, the message was received on the B bus. |
| 8 | N/A | Not Applicable. |
| 7 | ME | Message Error. Assertion of this bit indicates a message error condition was observed during processing. See bits 0 to 4 for details. |
| 6-5 | N/A | Not Applicable. |
| 4 | ILL | Illegal Command Received. Assertion of this bit indicates the command received was an illegal command. |
| 3 | N/A | Not Applicable. |
| 2 | OVR | Overrun Error. Assertion of this bit indicates the SRT received a data word with a Transmit Command. |
| 1-0 | N/A | Not Applicable. |

2.4 Mode Code and Subaddress

The S μ MMIT provides subaddress and mode code decoding that meets MIL-STD-1553B requirements. In addition, the

device has automatic internal illegal command decoding for reserved MIL-STD-1553B mode codes. Table 3 shows the SRT's response to all possible mode code combinations.

Table 3. Mode Code Descriptions

| T/R | Mode Code | Function | Operation |
|-----|-------------|--|---|
| 0 | 00000-01111 | Undefined (w/o data) | 1. Command word stored 2. Status word transmitted |
| 0 | 10000 | Undefined (with data) | 1. Command word stored 2. Data word stored 3. Status word transmitted |
| 0 | 10001 | Synchronize (with data) | 1. Command word stored 2. Data word stored 3. Time-Tag counter loaded with data word value 4. Status word transmitted |
| 0 | 10010 | Undefined | 1. Command word stored 2. Data word stored 3. Status word transmitted |
| 0 | 10011 | Undefined | 1. Command word stored 2. Data word stored 3. Status word transmitted |
| 0 | 10100 | Selected Transmitter Shutdown | 1. Command word stored 2. Data word stored 3. Status word transmitted |
| 0 | 10101 | Override Selected Transmitter Shutdown | 1. Command word stored 2. Data word stored 3. Status word transmitted |
| 0 | 10110-11111 | Reserved | 1. Command word stored 2. Data word stored 3. Status word transmitted |
| 1 | 00000 | Dynamic Bus Control | 1. Command word stored 2. Dynamic Bus Acceptance bit set in outgoing status word if enabled in the Control Register 3. Status word transmitted |
| 1 | 00001 | Synchronize | 1. Command word stored 2. Time-Tag counter reset to 0000 (hex) 3. Status word transmitted |
| 1 | 00010 | Transmit Status Word | 1. Command word stored 2. Last status word transmitted 3. Status word cleared after master reset Note: SRT updates status word if illegalized. |
| 1 | 00011 | Initiate Self-Test | 1. Command word stored 2. Status word transmitted 3. BIT initiated 4. TF bit set if BITF bit asserted |
| 1 | 00100 | Transmitter Shutdown | 1. Command word stored 2. Status word transmitted 3. Alternate bus disabled |

Table 3. Mode Code Descriptions (Cont.)

| T/R | Mode Code | Function | Operation |
|------------|------------------|--------------------------------|--|
| 1 | 00101 | Override Transmitter Shutdown | <ol style="list-style-type: none"> 1. Command word stored 2. Status word transmitted 3. Alternate bus enabled <p>Note: Reception of the override transmitter shutdown mode code does not enable a channel not previously enabled in the Control Register. Reset remote terminal mode code clears the transmitter shutdown function.</p> |
| 1 | 00110 | Inhibit Terminal Flag Bit | <ol style="list-style-type: none"> 1. Command word stored 2. Terminal flag bit set to zero and assertion disabled 3. Status word transmitted |
| 1 | 00111 | Override Inhibit Terminal Flag | <ol style="list-style-type: none"> 1. Command word stored 2. Terminal Flag bit enabled for assertion 3. Status word transmitted |
| 1 | 01000 | Reset Remote Terminal | <ol style="list-style-type: none"> 1. Command word stored 2. Status word transmitted 3. SRT reset, see section 2.8 for more information on software reset |
| 1 | 01001-01111 | Reserved | <ol style="list-style-type: none"> 1. Command word stored 2. Status word transmitted |
| 1 | 10000 | Transmit Vector Word | <ol style="list-style-type: none"> 1. Command word stored 2. Service request bit set to a logic zero in out going status 3. Status word transmitted 4. Data word transmitted 5. Clears the SRQ bit in the 1553 status word bits register (Register 9) |
| 1 | 10001 | Reserved | <ol style="list-style-type: none"> 1. Command word stored 2. Status word transmitted 3. Data word transmitted |
| 1 | 10010 | Transmit Last Command | <ol style="list-style-type: none"> 1. Command word not stored 2. Last status word transmitted 3. Last command word transmitted 4. Data word stored (Transmit Last Command) 5. Transmitted data word is all zero after reset <p>Note: The SRT stores the Transmit Last Command mode code if illegalized and updates status word.</p> |
| 1 | 10011 | Transmit BIT Word | <ol style="list-style-type: none"> 1. Command word stored 2. Status word transmitted 3. BIT word transmitted from BIT Word Register 4. Data word stored (Transmit BIT Word) |
| 1 | 10100-10101 | Undefined (with data) | <ol style="list-style-type: none"> 1. Command word stored 2. Status word transmitted 3. Data word transmitted |
| 1 | 10110-11111 | Reserved | <ol style="list-style-type: none"> 1. Command word stored 2. Status word transmitted 3. Data word transmitted |

2.5 Encoder and Decoder

The SRT interfaces directly to a transmitter/receiver via the SRT Manchester II encoder/decoder. The SRT receives the command word from the MIL-STD-1553 bus and processes it either by the primary or secondary decoder. Each decoder checks for the proper sync pulse and Manchester waveform, edge skew, correct number of bits, and parity. If the command is a receive command, the SRT processes each incoming data word for correct format, word count, and contiguous data. If a message error is detected, the SRT stops processing the remainder of the message (i.e., DMAs), suppresses status word transmission, and asserts bit 9 (ME bit) of the status word. The SRT will track the message until proper word count is finished.

The SRT automatically compares the transmitted word (encoder word) to the reflected decoder word by way of the continuous loop-back feature. If the encoder word and reflected word do not match, the WRAPF bit is asserted in the BIT Word Register and the $\overline{\text{YF_INT}}$ will be generated, if enabled. In addition to the loop-back compare test, a timer precludes a transmission greater than 800 μs by the assertion of Fail-Safe Timer ($\overline{\text{TIMERONA}}$ or $\overline{\text{TIMERONB}}$). This timer is reset upon receipt of another command. Remote Terminal Response Time:

MIL-STD-1553A = 7 μs

MIL-STD-1553B = 10 μs

Data Contiguity Time-Out = 1.0 μs

2.6 RT-RT Transfer Compare

The RT-to-RT Terminal Address compare logic ensures that the incoming status word's Terminal Address matches the Terminal Address of the transmitting RT specified in the command word. An incorrect match results in setting the message-error bit and suppressing transmission of the status word. (RT-to-RT transfer time-out = 55 to 59 μs). The receiving SRT does not check ME or SSYSF of the transmitting remote terminal.

2.7 Terminal Address

The SRT Terminal Address is programmed via six input pins: RTA(4:0) and RTPTY. Negating $\overline{\text{MRST}}$ latches the SRT's Terminal Address from pins RTA(4:0) and parity bit RTPTY. The address and parity cannot change until the next assertion and negation of the $\overline{\text{MRST}}$ input (for $\overline{\text{LOCK}} = 0$). The Terminal Address parity is odd; input pin RTPTY is set to a logic state to satisfy this requirement. Assertion of Operational Status Register bit 2 (TAPF) indicates incorrect Terminal Address parity. The Operational Status Register bit 2 is valid after the rising edge of $\overline{\text{MRST}}$.

For example:

RTA(4:0) = 05 (hex) = 00101 (binary)

RTPTY = 1, Sum of 1s = 3 (odd), Operational Status Register Bit 2 = 0

RTA(4:0) = 04 (hex) = 00100 (binary)

RTPTY = 0, Sum of 1s = 1 (odd), Operational Status Register Bit 2 = 0

RTA(4:0) = 04 (hex) = 00100 (binary)

RTPTY = 1, Sum of 1s = 2 (even), Operational Status Register Bit 2 = 1

Note:

- The SRT checks the Terminal Address and parity after the SRT has been started. With Broadcast disabled, RTA(4:0)=11111 operates as a normal RT address.
- The BIT Word Register parity fail bit is valid after the SRT has been started.
- The Terminal Address is also programmed via a write to the Operational Status Register ($\overline{\text{LOCK}} = 1$). The SRT loads the Terminal Address on the completion of the Control Register write which starts the SRT.
- YF_INT occurs if enabled.

2.8 Reset

The S μ MMIT provides for several different reset mechanisms. The S μ MMIT software reset (Control Register Bit 13) is equal to a master reset and takes 5 μs to complete. Assertion of this bit results in the immediate reset of the SRT and termination of command processing. The host or subsystem is responsible for the re-initialization of the SRT for operation. Configuration of the device for auto-initialization frees the host or subsystem from this task.

A Reset Remote Terminal mode code (Mode Code 01000, $\overline{\text{T/R}} = 1$) is equal to a master reset only if $\overline{\text{AUTOEN}}$ is enabled. If $\overline{\text{AUTOEN}}$ is not enabled, the reset remote terminal mode code clears the encoder/decoders, resets the time-tag, enables the channels to the programmed host state, and re-enables the Terminal Flag for assertion. This reset is performed after the transmission of the 1553 Status word. All outputs have asynchronous reset with the following exceptions: $\overline{\text{DMACK}}$, $\overline{\text{DMAR}}$, D(15:0), A(15:0), $\overline{\text{MSG_INT}}$, $\overline{\text{RWR}}$, $\overline{\text{RCS}}$, and $\overline{\text{RRD}}$. To reset these signals, apply three clock cycles before the rising edge of $\overline{\text{MRST}}$.

Caution: Per the MIL-STD-1553 specification (sections 4.3.3.5.1.7.9 and 30.4.3), a remote terminal must “complete the reset function within 5μs following transmission of the status word.” If the $\overline{\text{AUTOEN}}$ function is enabled in the SμMMIT, reset may require additional time depending on the application.

2.9 MIL-STD-1553A Operation

To maximize flexibility, the SμMMIT has been designed to operate in many different systems which use various protocols. Specifically, two of the protocols that the SμMMIT may be interfaced to are MIL-STD-1553A and MIL-STD-1553B. To meet these protocols, the SμMMIT may be configured through an external pin or through control register bits (depending on the state of the $\overline{\text{LOCK}}$ pin). Table 4 defines the three ways to program the SμMMIT.

Table 4. MIL-STD-1553A Operation

| $\overline{\text{A/B STD}}$ (pin or bit) | $\overline{\text{XMTSW}}$ (bit only) | RESULT (protocol selected) |
|---|---|---|
| 0 | X | 1553B response, 1553B Standard |
| 1 | 0 | 1553A response, 1553A Standard |
| 1 | 1 | 1553A response, Auto execute the TRANSMIT STATUS WORD mode code |

When configured as a remote terminal to meet MIL-STD-1553A, the SμMMIT will operate as follows:

- Responds with a status word within 7μs;
- Ignores the T/R bit for all mode codes;
- All mode codes are defined without data;
- All mode codes use mode code transmit control and information words;
- Mode code 00000 is defined as Dynamic Bus Control (DBC);
- Subaddress 00000 defines a mode code;
- ME and TF bits are defined in the 1553 status word; all other status word bits are programmable (i.e., NO BUSY mode, etc.);
- Broadcast of all mode codes, except Mode Code 00000 (DBC) and Mode Code 00010 (Transmit Status word if enabled), is allowed;
- To illegalize a Mode Code, the user needs to illegalize both the receive and transmit versions;
- Illegalization of row 1F (hex) is not automatic.

3.0 BUS CONTROLLER ARCHITECTURE

The S μ MMIT bus controller (SBC) is an interface device linking a MIL-STD-1553 serial data bus to a host microprocessor and/or subsystem. The SBC's architecture is based on a Command Block structure and internal, programmable registers. Designed to run autonomously and reduce host overhead, the SBC's RISC-based core automatically executes data handling, message error checking, memory control, and related protocol functions. This section discusses the following SBC features and functions:

- Multiple Message Processing
- Message Scheduling
- Polling Capability
- Executable Architecture
- Built-In Test
- Interrupt Structure
- Memory Management

3.1 Register Descriptions

To initialize the S μ MMIT as a bus controller, the designer must understand the internal registers. The SBC registers offer many programmable functions and allow host access to extensive information. All register bits are active high and reflect a logic zero condition (0000 hex) after Master Reset (except those reflecting input pins). Each register associated with the bus controller mode of operation is individually described below.

| Register Number | Name | Register Address |
|-----------------|--|--------------------|
| 0 | Control Register | 0000 (hex) |
| 1 | Operational Status Register | 0001 (hex) |
| 2 | Current Command Register | 0002 (hex) |
| 3 | Interrupt Mask Register | 0003 (hex) |
| 4 | Pending Interrupt Register | 0004 (hex) |
| 5 | Interrupt Log List Pointer Register | 0005 (hex) |
| 6 | BIT Word Register | 0006 (hex) |
| 7 | Minor-Frame Timer | 0007 (hex) |
| 8 | Command Block Pointer Register | 0008 (hex) |
| 9 | Not Applicable | 0009 (hex) |
| 10 | BC Command Block Initialization Count Register | 000A (hex) |
| 11-31 | Not Applicable | 000B to 001F (hex) |

Note: Reference section 9.1.2 for S μ MMIT XTE 8-bit register address numbers.

3.1.1 Control Register (Read/Write)- Register 0

The Control Register's function is to configure the S μ MMIT for operation. To make changes to the SBC and this register, the STEX bit (Bit 15) must be logic zero. To operate the S μ MMIT as a bus controller (SBC), use the following bits.

| Bit Number | Mnemonic | Description |
|------------|----------|---|
| 15 | STEX | Start Execution. Assertion of this bit commences operation of the S μ MMIT. A Control Register write negating this bit inhibits operation of the S μ MMIT. After execution begins, a write of logic zero will halt the SBC after completing the current opcode. Prior to halting, the SBC determines the next command block pointer address and loads the value into Register 8. For an EOL command block, Register 8 is not updated. |
| 14 | SBIT | Start BIT. Assertion of this bit places the S μ MMIT into the Built-In Test routine. The BIT test has a fault coverage of 93.4%. Once the S μ MMIT has been started, the host must halt the device in order to place the S μ MMIT into the Built-In Test routine (STEX = 0) or use the bit opcode. Note: If Start BIT (SBIT) and Start Execution (STEX) are both set on one register write, BIT has priority. |
| 13 | SRST | Software Reset. Assertion of this bit immediately places the S μ MMIT into a software reset. Like \overline{MRST} , the software reset (which takes 5 μ s to execute) clears all internal logic. Note: During auto-initialization, do not load this bit with a logic one. SRST will only function after \overline{READYB} is asserted. |
| 12-11 | N/A | Not Applicable. |
| 10 | ETCE | External Timer Clock Enable. Assertion of this bit enables an external clock used with an internal counter for variable minor frame timing. Refer to section 3.1.8. Note: The user can only change the clock frequency before starting the device (i.e., setting bit 15 of Register 0 to a logic one). |
| 9 | -- | See section 5, Enhanced S μ MMIT Family Operation, for additional information. |
| 8-7 | N/A | Not Applicable. |
| 6 | BUFR | Buffer Mode Enable. Assertion of this bit enables the buffer mode of operation. Refer to section 9.1.5 or 9.2.3 for additional information. |
| 5 | N/A | Not Applicable. |
| 4 | BCEN | Broadcast Enable. Assertion of this bit enables the broadcast option for the SBC. Negation of this bit enables the remote terminal address 31 as a unique RT address. When enabled, the SBC does not expect a status word response from the remote terminal. |
| 3 | N/A | Not Applicable. |
| 2 | PPEN | Ping-Pong Enable. This bit controls the method by which the SBC will retry messages. A logic one allows the SBC to ping-pong between buses during retries. A logic zero dictates that all retries will be performed on the programmed bus as defined in the Command Block control word. (Section 3.2.1 of this document defines the retry bit). |
| 1 | INTEN | Interrupt Log List Enable. Assertion of this bit enables the Interrupt Log List. Negation of this bit prevents the logging of interrupts as they occur. |
| 0 | N/A | Not Applicable. |

3.1.2 Operational Status Register (Read/Write) - Register 1

This register provides pertinent status information for the SBC and is not reset to 0000 (hex) on $\overline{\text{MRST}}$. Instead, the register reflects the actual stimulus applied to input pins MSEL(1:0), $\overline{\text{A/B STD}}$, and $\overline{\text{LOCK}}$. Assertion of the $\overline{\text{LOCK}}$ input prevents the modification of the mode selects and the A or B standard bits. In this case, a write to this register's most significant nine bits is meaningless. If $\overline{\text{LOCK}}$ is negated, a read of this register reflects the information written into this register's most significant nine bits.

Note: To make changes to the SBC and this register, the STEX bit (Register 0, bit 15) must be logic zero.

| Bit Number | Mnemonic | Description | | | | | | | | | | | | | | | |
|------------|-----------------------------|--|---------|---------|-------------------|---|---|----------------------|---|---|-----------------------|---|---|------------------------|---|---|---------|
| 15-10 | N/A | Not Applicable. | | | | | | | | | | | | | | | |
| 9 | MSEL(1) | Mode Select 1. In conjunction with Mode Select 0, this bit determines the S μ MMIT mode of operation. | | | | | | | | | | | | | | | |
| 8 | MSEL(0) | Mode Select 0. In conjunction with Mode Select 1, this bit determines the S μ MMIT mode of operation. | | | | | | | | | | | | | | | |
| | | <table border="1"> <thead> <tr> <th>MSEL(1)</th> <th>MSEL(0)</th> <th>Mode of Operation</th> </tr> </thead> <tbody> <tr> <td>0</td> <td>0</td> <td>Bus Controller = SBC</td> </tr> <tr> <td>0</td> <td>1</td> <td>Remote Terminal = SRT</td> </tr> <tr> <td>1</td> <td>0</td> <td>Monitor Terminal = SMT</td> </tr> <tr> <td>1</td> <td>1</td> <td>SMT/SRT</td> </tr> </tbody> </table> | MSEL(1) | MSEL(0) | Mode of Operation | 0 | 0 | Bus Controller = SBC | 0 | 1 | Remote Terminal = SRT | 1 | 0 | Monitor Terminal = SMT | 1 | 1 | SMT/SRT |
| MSEL(1) | MSEL(0) | Mode of Operation | | | | | | | | | | | | | | | |
| 0 | 0 | Bus Controller = SBC | | | | | | | | | | | | | | | |
| 0 | 1 | Remote Terminal = SRT | | | | | | | | | | | | | | | |
| 1 | 0 | Monitor Terminal = SMT | | | | | | | | | | | | | | | |
| 1 | 1 | SMT/SRT | | | | | | | | | | | | | | | |
| 7 | $\overline{\text{A/B STD}}$ | Military Standard 1553A or 1553B. This bit determines whether the SBC will operate under MIL-STD-1553A or 1553B protocol. Assertion of this bit forces the SBC to look for all responses in 9 μ s or generate time-out errors. Negation of this bit automatically allows the SBC to operate under the MIL-STD-1553B protocol. See section 3.6 and section 5.0, Enhanced S μ MMIT Family Operation, for additional information. | | | | | | | | | | | | | | | |
| 6 | LOCK | $\overline{\text{LOCK}}$ Pin. This read-only bit reflects the inverted state of the $\overline{\text{LOCK}}$ input pin and is latched on the rising edge of $\overline{\text{MRST}}$. | | | | | | | | | | | | | | | |
| 5 | AUTOEN | $\overline{\text{AUTOEN}}$ Pin. This read-only bit defines whether or not the auto enable feature will be used in the design. This bit shows the inverse of the auto enable ($\overline{\text{AUTOEN}}$) input pin. | | | | | | | | | | | | | | | |
| 4 | N/A | Not Applicable. | | | | | | | | | | | | | | | |
| 3 | EX | S μ MMIT Executing. This read-only bit indicates whether the SBC is presently executing or is idle. A logic one indicates that the S μ MMIT is executing; logic zero indicates the S μ MMIT is idle. | | | | | | | | | | | | | | | |
| 2 | N/A | Not Applicable. | | | | | | | | | | | | | | | |
| 1 | READY | $\overline{\text{READY}}$ Pin. This read-only bit reflects the inverted state of the output pin $\overline{\text{READY}}$ and is cleared on reset. | | | | | | | | | | | | | | | |
| 0 | TERACT | $\overline{\text{TERACT}}$ Pin. Assertion of this bit indicates that the SBC is presently executing. This read-only bit reflects the inverted state of output pin $\overline{\text{TERACT}}$ and is cleared on reset. | | | | | | | | | | | | | | | |

Note: When STEX transitions from 0 to 1, EX and $\overline{\text{TERACT}}$ stay active until command processing is complete.

3.1.3 Current Command Register (Read-only) - Register 2

This register contains the last 1553 command that was transmitted by the SBC. Upon the execution of each Command Block, this register will automatically be updated. This register is updated when transmission of the Command Word begins. In a RT-RT transfer, the register will reflect the latest Command Word as it is transmitted.

| Bit Number | Mnemonic | Description |
|-------------------|-----------------|---|
| 15-0 | CC(15:0) | Current Command. These bits contain the latest 1553 command that was transmitted by the bus controller. |

3.1.4 Interrupt Mask Register (Read/Write) - Register 3

The SBC interrupt architecture allows the host to mask or temporarily disable the service of interrupts. While masked, interrupt activity does not occur. The unmasking of an interrupt after the event occurs does not generate an interrupt for that event. An interrupt is masked if the corresponding bit of this register is set to a logic zero.

| Bit Number | Mnemonic | Description |
|-------------------|-----------------|-----------------------------------|
| 15 | DMAF | DMA Fail Interrupt. |
| 14 | WRAPF | Wrap Fail Interrupt. |
| 13 | N/A | Not Applicable. |
| 12 | BITF | BIT Fail Interrupt. |
| 11 | MERR | Message Error Interrupt. |
| 10-6 | N/A | Not Applicable. |
| 5 | EOL | End Of List Interrupt. |
| 4 | ILLCMD | Illogical Command Interrupt. |
| 3 | ILLOP | Illogical Opcode Interrupt. |
| 2 | RTF | Retry Fail Interrupt. |
| 1 | CBA | Command Block Accessed Interrupt. |
| 0 | N/A | Not Applicable. |

3.1.5 Pending Interrupt Register (Read-only) - Register 4

This register is used to identify which of the interrupts occurred during operation. The assertion of any bit in this register asserts an output pin, $\overline{\text{MSG_INT}}$ or $\overline{\text{YF_INT}}$ (three clock cycles). Writing to the most significant four bits of this register generates a $\overline{\text{YF_INT}}$.

| Bit Number | Mnemonic | Description |
|------------|----------|--|
| 15 | DMAF | DMA Fail Interrupt. Once the S μ MMIT has issued the $\overline{\text{DMAR}}$ signal, an internal timer is started. If all DMA activity (which includes $\overline{\text{DMAR}}$, $\overline{\text{DMAG}}$, and all $\overline{\text{DTACK}}$) has not been completed, the interrupt is generated. In the SBC mode, the $\overline{\text{YF_INT}}$ interrupt is generated (if not masked) and command processing stops. |
| 14 | WRAPF | Wrap Fail Interrupt. The SRT automatically compares the transmitted word (encoder word) to the reflected decoder word by way of the continuous loop-back feature. If the encoder word and reflected word do not match, the WRAPF bit asserts and the $\overline{\text{YF_INT}}$ interrupt is generated (if not masked). The loop-back path is via the MIL-STD-1553 bus transceiver. |
| 13 | N/A | Not Applicable. |
| 12 | BITF | BIT Fail Interrupt. Assertion of this bit indicates a BIT failure. Interrogate Bit Word Register bits 11 and 10 to determine the specific failure. In SBC mode, the $\overline{\text{YF_INT}}$ interrupt is generated (if not masked) and command processing stops if initiated by opcode. |
| 11 | MERR | Message Error Interrupt. Assertion of this bit indicates the occurrence of a message error. The SBC can detect Manchester, sync-field, word count, 1553 word parity, bit count, and protocol errors. This bit will be set and an $\overline{\text{MSG_INT}}$ interrupt generated (if not masked) after message processing is complete. |
| 10-6 | N/A | Not Applicable. |
| 5 | EOL | End Of List Interrupt. Assertion of this bit indicates that the SBC is at the end of the command block. $\overline{\text{MSG_INT}}$ generated (if not masked). |
| 4 | ILLCMD | Illogical Command Interrupt. Assertion of this bit indicates that an illogical command (i.e., Transmit Broadcast or improperly formatted RT-RT message) was written into the Command Block. The SBC checks for RT-RT Terminal address field match, RT-RT transmit/receive bit mismatch and correct order, and broadcast transmit commands. If illogical commands occur, the SBC will halt execution. $\overline{\text{MSG_INT}}$ generated (if not masked). |
| 3 | ILLOP | Illogical Opcode Interrupt. Assertion of this bit indicates an illogical opcode (i.e., any reserved opcode) was used in the command block. The SBC halts operation if this condition occurs. $\overline{\text{MSG_INT}}$ generated (if not masked). |
| 2 | RTF | Retry Fail Interrupt. Assertion of this bit indicates all programmed retries failed. $\overline{\text{MSG_INT}}$ generated (if not masked). |
| 1 | CBA | Command Block Accessed Interrupt. Assertion of this bit indicates a command block was accessed (Opcode 1010), if enabled. $\overline{\text{MSG_INT}}$ generated (if not masked). |
| 0 | N/A | Not Applicable. |

Note: The user must read or write a S μ MMIT register after reading the Pending Register to invoke the automatic clear of the Pending Interrupt Register. For example, a Subaddress Access interrupt results in a Pending Interrupt Register of 0400₁₆. A read of the Pending Interrupt Register returns a value of 0400₁₆. A subsequent read of the Interrupt Mask Register (i.e., Register 3₁₆), followed by a Pending Interrupt Register read returns a value of 0000₁₆. The intervening read of the Interrupt Mask Register clears the Pending Interrupt Register at the end of the Interrupt Mask Register read.

3.1.6 Interrupt Log List Pointer Register (Read/Write) - Register 5

The Interrupt Log List Pointer indicates the starting address of the Interrupt Log List. The Interrupt Log List is a 32-word ring-buffer that contains information pertinent to the service of interrupts. The S μ MMIT architecture requires the location of the Interrupt Log List on a 32-word boundary. The most significant 11 bits of this register designate the location of the Interrupt Log List within a 64K memory space. Initialize the lower five bits of this register to a logic zero. The S μ MMIT controls the lower five bits to implement the ring-buffer architecture. The host or subsystem reads this register to determine the location and number of interrupts within the Interrupt Log List (least significant five bits).

| Bit Number | Mnemonic | Description |
|------------|------------|---|
| 15-0 | INTA(15:0) | Interrupt Log List Pointer Bits. These bits indicate the starting location of the Interrupt Log List. |

3.1.7 BIT Word Register (Read/Write) - Register 6

This register contains information on the current health of the SBC. The lower eight bits of this register are user-defined.

| Bit Number | Mnemonic | Description |
|------------|-----------|---|
| 15 | DMAF | DMA Fail. Assertion of this bit indicates that all DMA activity had not been completed from the time $\overline{\text{DMAR}}$ asserts to when the timer decrements to zero (i.e., 16 μ s). The DMA activity includes $\overline{\text{DMAR}}$ to $\overline{\text{DMAG}}$, and all wait states. In the event of a DMA failure, current processing terminates. DMAF asserts, and YF_INT is generated (if not masked). |
| 14 | WRAPF | Wrap Fail. The SBC automatically compares the transmitted word (encoder word) to the reflected decoder word by way of the continuous loop-back feature. If the encoder word and reflected word do not match, the WRAPF bit asserts. The loop-back path is via the MIL-STD-1553 bus transceiver. |
| 13 | N/A | Not Applicable. |
| 12 | BITF | BIT Fail. Assertion of this bit indicates a BIT failure. Interrogate bit 11 through 8 to determine the specific failure. |
| 11 | CHAF | Channel A Fail. Assertion of this bit indicates a BIT test failure in Channel A. |
| 10 | CHBF | Channel B Fail. Assertion of this bit indicates a BIT test failure in Channel B. |
| 9 | MSBF/UDB | Memory Test Fail. Most significant memory byte failure (S μ MMIT XTE). User-Defined Bits (S μ MMIT E & S μ MMIT LXE/DXE). |
| 8 | LSBF/UDB | Memory Test Fail. Least significant memory byte failure (S μ MMIT XTE). User-Defined Bits (S μ MMIT E & S μ MMIT LXE/DXE). |
| 7-0 | UDB (7:0) | User-Defined Bits. |

3.1.8 Minor Frame Timer Register (Read-only) - Register 7

This register is loaded via the Minor Frame Timer (MFT) opcode (Opcode 1110). For user-defined resolution use TCLK. Register resets to zero anytime operation halts.

| Bit Number | Mnemonic | Description |
|------------|-----------|--|
| 15-0 | MFT(15:0) | Minor Frame Timer. These bits indicate the value of the Timer. |

3.1.9 Command Block Pointer Register (Read/Write) - Register 8

This register contains the location to start the Command Blocks. After execution begins, this register is automatically updated with the address of the next block.

| Bit Number | Mnemonic | Description |
|-------------------|-----------------|--|
| 15-0 | CBA(15:0) | Command Block Address. These bits indicate the starting location of the Command Block. |

3.1.10 BC Command Block Initialization Count Register (Read/Write)-Register 10

This register contains the number of command blocks that will be initialized when using the auto-initialize feature. If 0000 (hex) is written into this register, then NO blocks will be set up. Because each Command Block requires eight contiguous memory locations, the largest value allowed in this register is 1FFF (hex). If a larger value is written into this register, the SBC ignores the three most significant bits.

| Bit Number | Mnemonic | Description |
|-------------------|-----------------|--|
| 15-0 | CBC(15:0) | Command Block Count. These bits indicate the number of Command Blocks set up during auto-initialization. |

3.2 SBC Architecture

As defined in MIL-STD-1553, the bus controller initiates all communications on the bus. To meet MIL-STD-1553 bus controller requirements, the S μ MMIT utilizes a Command Block architecture that takes advantage of both internal registers and external memory. Each command word transmitted over the bus must be associated with a Command Block. The Command Block requires eight contiguous memory locations for each message. These eight locations include a control word, two command word locations, a data pointer, two status word locations, a branch address location, and a timer value.

The host, or ROM for autonomous operation, must initialize each of the locations associated with each Command Block (the exception is for the two status locations which will be updated as command words are transmitted and corresponding status words are received). Figure 8 shows the SBC's Command Block architecture while Sections 3.2.1 through 3.2.6 describe each location associated with the Command Block.

| |
|-----------------------|
| Control Word |
| Command Word 1 |
| Command Word 2 |
| Data Pointer |
| Status Word 1 |
| Status Word 2 |
| Branch Address |
| Timer Value |

Figure 8. Command Block Definition

3.2.1 Control Word

The first memory location of each SBC Command Block contains the control word. Each control word contains the opcode, retry number, bus definition, RT-RT instruction, condition codes, and the block access message error. The SBC's control word is defined below.

| | | | | | | | | |
|--------|---------|----|----------------|-------|-----------------|---|-----------------|---|
| 15 | 12 | 11 | 10 | 9 | 8 | 7 | 1 | 0 |
| Opcode | Retry # | | CHA/ \bar{B} | RT-RT | Condition Codes | | Block Access ME | |

Bit Number

Description

| | | | |
|-------|--|--------|--------------|
| 15-12 | Opcode. These bits define the opcode to be used by the SBC for that particular Command Block. If the opcode does not perform any 1553 function, all other bits are ignored. Each of the available opcodes is defined in section 3.2.1.1. | | |
| 11-10 | Retry Number. These bits define the number of retries for each individual Command Block and if a retry opcode is used. If bit 2 of the Control Register is not enabled, all retries will occur on the programmed bus. However, if bit 2 is enabled, the first retry will always occur on the alternate bus, the second retry will occur on the primary bus, the third retry will occur on the alternate bus, and the fourth retry will occur on the primary bus. | | |
| | BIT 11 | BIT 10 | # of Retries |
| | 0 | 1 | 1 |
| | 1 | 0 | 2 |
| | 1 | 1 | 3 |
| | 0 | 0 | 4 |
| 9 | Bus A/ \bar{B} . This bit defines on which of the two buses the command will be transmitted (i.e., primary bus). (Logic 1 = Bus A, Logic 0 = Bus B). | | |
| 8 | RT-RT Transfer. This bit defines whether or not the present Command Block is a RT-RT transfer and if the SBC should transmit the second command word. Data associated with a RT-RT is always stored by the SBC (Logic 1 = RT-RT). | | |
| 7-1 | Condition Codes. These bits define the condition code the SBC uses for that particular Command Block. Each of the available condition codes are defined in section 3.2.1.2. | | |
| 0 | Block Access Message Error. Assertion of this bit indicates a protocol message error occurred in the RT's response. For this occurrence, the SBC will overwrite this bit prior to storing the Control Word into memory. Noise on the 1553 bus may be one example of such an error. | | |

3.2.1.1 Opcode Definition

| Opcode | Definition |
|---------------|--|
| 0000 | End Of List. This opcode instructs the SBC that the end of the command block has been encountered. Command processing stops and the interrupt is generated if the interrupt is enabled. No command processing takes place (i.e., no 1553). |
| 0001 | Skip. This opcode instructs the SBC to load the message-to-message timer with the value stored in timer value location. The S μ MMIT will then wait the specified time before proceeding to the next command block. This opcode allows for scheduling of specific time between message execution. No command processing takes place (i.e., no 1553). |
| 0010 | Go To. This opcode instructs the SBC to “go to” the command block as specified in the branch address location. No command process takes place (i.e., no 1553). |
| 0011 | Built-in Test. This opcode instructs the SBC to perform an internal built-in test. If the device passes the built-in test, then processing of the next command block will continue. However if the device fails the built-in test, then processing stops and an interrupt is generated, if the interrupt is enabled. No command processing takes place (i.e., no 1553). |
| 0100 | Execute Block; Continue. This opcode instructs the SBC to execute the current command block and proceed to the next command block. This opcode allows for continuous operations. |
| 0101 | Execute Block; Branch. This opcode instructs the SBC to execute the current command block and unconditionally branch to the location as specified in the branch address location. |
| 0110 | Execute Block; Branch on Condition. This opcode instructs the SBC to execute the current command block and branch only if the condition is met. If no conditions are met, the opcode appears as an execute and continue. |
| 0111 | Retry on Condition. This opcode instructs the SBC to perform automatic retries, as specified in the control word, if particular conditions occur. If no conditions are met, the opcode appears as an execute and continue. |
| 1000 | Retry on Condition; Branch. This opcode instructs the SBC to perform automatic retries, as specified in the control word, if particular conditions occur. If the conditions are met, the SBC retries. Once all retries have executed, the SBC branches to the location as specified in the branch address location. If no conditions are met, the opcode appears as an execute and branch. |
| 1001 | Retry on Condition; Branch if all Retries Fail. This opcode instructs the SBC to perform automatic retries, as specified in the control word, if particular conditions occur. If the conditions are met and all the retries fail, the SBC branches to the location as specified in the branch address location. If no conditions are met, the opcode appears as an execute and continue. |
| 1010 | Interrupt; Continue. This opcode instructs the SBC to interrupt and continue processing on the next command block. No command processing takes place (i.e., no 1553). |
| 1011 | Call. This opcode instructs the SBC to “go to” the command block as specified in the branch address location without processing this block. The next command block address is saved in an internal register so that the S μ MMIT may remember one address and return to the next command block. No command processing takes place (i.e., no 1553). |
| 1100 | Return to Call. This opcode instructs the SBC to return to the command block address saved during the Call opcode. No command processing takes place (i.e., no 1553). |
| 1101 | Reserved. The SBC will generate an illegal opcode interrupt (if interrupt enabled) and automatically stop execution if a reserved opcode is used. |

| Opcode | Definition |
|--------|--|
| 1110 | Load Minor Frame Timer. This opcode instructs the SBC to load the minor frame timer (MFT) with the value stored in the eighth location of the current command block. The timer will be loaded after the previous MFT has decremented to zero. After the MFT timer is loaded with the new value, the SBC will proceed to the next command block. No command processing takes place (i.e., no 1553). |
| 1111 | Return to Branch. This opcode instructs the SBC to return to the command block address saved during a Branch opcode. No command processing takes place (i.e., no 1553). |

Note: For retries with interrupts enabled, all interrupts are logged after message processing is complete.

3.2.1.2 Condition Codes

Condition codes have been provided as a means for the SBC to perform certain functions based on the RT's status word. In a RT-RT transfer, the conditions apply to both of the status words. Each bit of the condition codes is defined below.

| Bit Number | Description |
|------------|---|
| 7 | Message Error. This condition will be met if the SBC detects an error in the RT's response, or if it detects no response. (The SBC will wait 15 μ s in 1553B mode and 9 μ s in 1553A mode before declaring a RT no response.) See section 5.0, Enhanced S μ MMIT Family Operation for additional information. |
| 6 | Status Word Response with the Message Error bit set (Bit time 9 in 1553A mode). This condition is met if the SBC detects that the RT's status word has the Message Error bit set. |
| 5 | Status Word Response with the Busy bit set (Bit time 16 in 1553A mode). This condition is met if the SBC detects that the RT's status word has the Busy bit set. |
| 4 | Status Word Response with the Terminal Flag bit set (Bit time 19 in 1553A mode). This condition is met if the SBC detects that the RT's status word has the Terminal Flag bit set. |
| 3 | Status Word Response with the Subsystem Fail bit set (Bit time 17 in 1553A mode). This condition is met if the SBC detects that the RT's status word has the Subsystem Fail bit set. |
| 2 | Status Word Response with the Instrumentation bit set (Bit time 10 in 1553A mode). This condition is met if the SBC detects that the RT's status word has the Instrumentation bit set. |
| 1 | Status Word Response with the Service Request bit set (Bit time 11 in 1553A mode). This condition is met if the SBC detects that the RT's status word has the Service Request bit set. |

3.2.2 Command Words

The next two locations of the SBC Command Block are for 1553 command words. In most 1553 messages, only the first command word needs to be initialized. However, in a RT-RT transfer, the first command word is the Receive Command and the second command word is the Transmit Command.

3.2.3 Data Pointer

The fourth location in the SBC Command Block is the data pointer that points to the first memory location to store or fetch the data words associated with the message for that command block. This data structure allows the SBC to store or fetch the

exact specified number of data words, thus saving memory space and providing efficient space allocation. (Note: In a RT-RT transfer, the SBC uses the data pointer as the location in memory to store the transmitted data in the transfer.)

One common application for the data pointer occurs when the SBC needs to send the same data words to several RTs. Here, each Command Block associated with those messages would contain the same data pointer value, and, therefore, fetch and transmit the same data. Note that the Data Pointer is never updated (i.e., the SBC reads and writes the pointer but never changes its value).

3.2.4 Status Words

The next two locations in the SBC Command Block are for status words. As the RT responds to the BC's command, the corresponding status word will be stored in Status Word 1. In a RT-RT transfer, the first status word will be the status of the Transmitting RT while the second status word will be the status of the Receiving RT.

3.2.5 Branch Address

The seventh location in the SBC Command Block contains the starting location of the branch. This location simply allows the SBC to branch to another location in memory when certain opcodes are used.

3.2.6 Timer Value

The last location in the SBC Command Block is the Timer Value. This timer is used for one of two purposes. First, the value may be used to set up minor frame schedules when using the Load Minor Frame Timer opcode (1110). The MFT counter may be driven by the TCLK input. If not driven by the TCLK input, the MFT counter is clocked at a period of 64 μ s by an internal clock.

The MFT counter runs continuously during message processing and must decrement to zero prior to loading the next Minor Frame time value. Second, the value may be used as a message-to-message timer (MMT) when using the Skip opcode (0001). The MMT timer is clocked at the 24MHz rate and allows for scheduling of specific time between message execution.

3.3 Command Block Chaining

The host determines the first Command Block by setting the initial start address in the Command Block Pointer Register (Reg 8). The Command Blocks will execute in a contiguous fashion as long as no "go to", "branch", "call", or "return" opcodes are used. With the use of these opcodes, almost any memory configuration is possible. Figures 9a, 9b and 10 show how several Command Blocks may be linked together to form a command frame and how branch opcodes may be used to link minor frames. The minimum BC intermessage gap is 28.0 μ s.

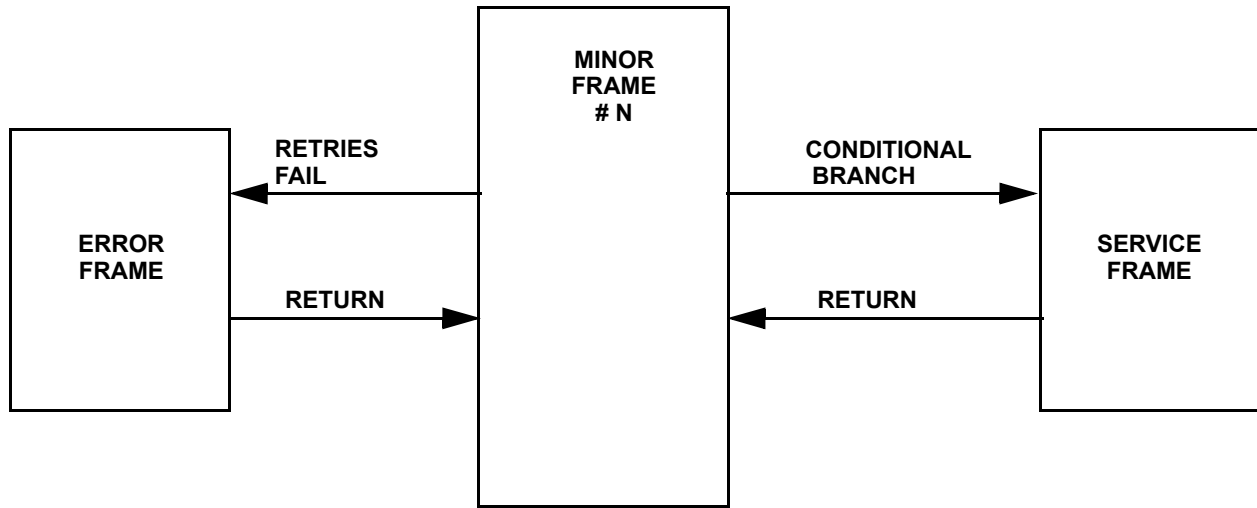

Figure 9a. Minor Frame Branching

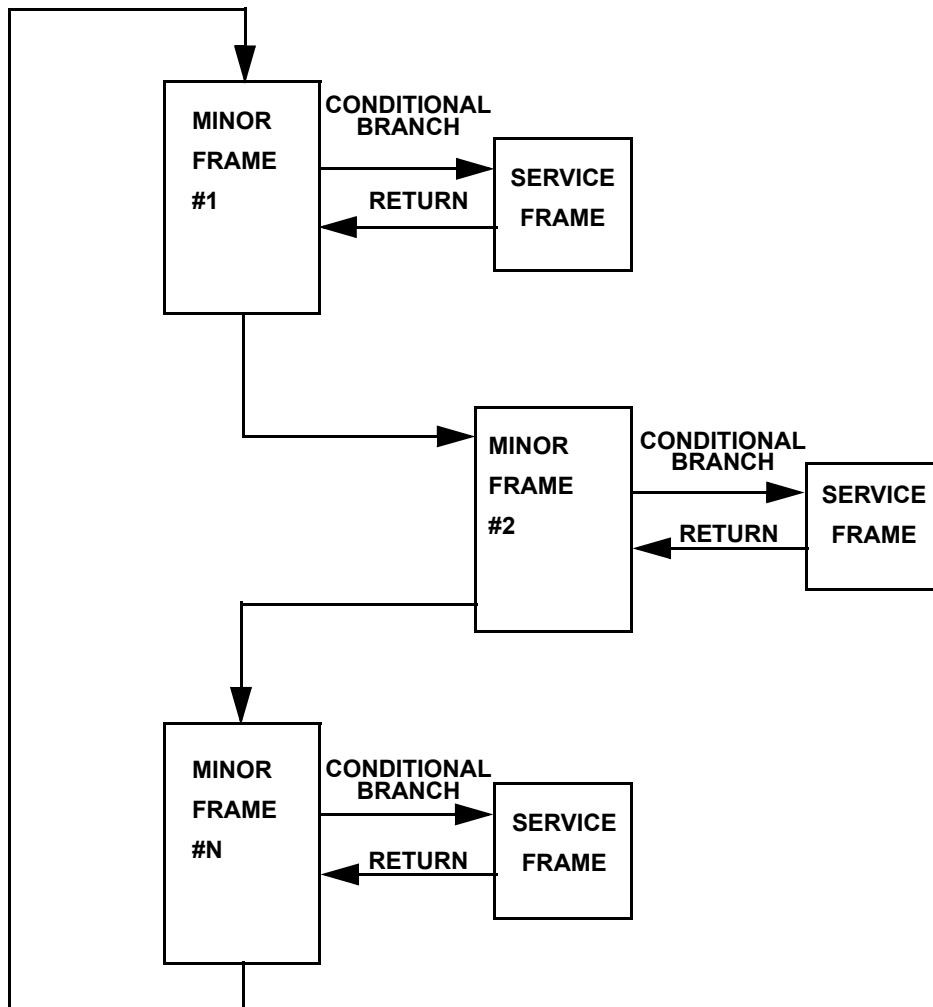

Figure 9b. Major Frame Sequencing

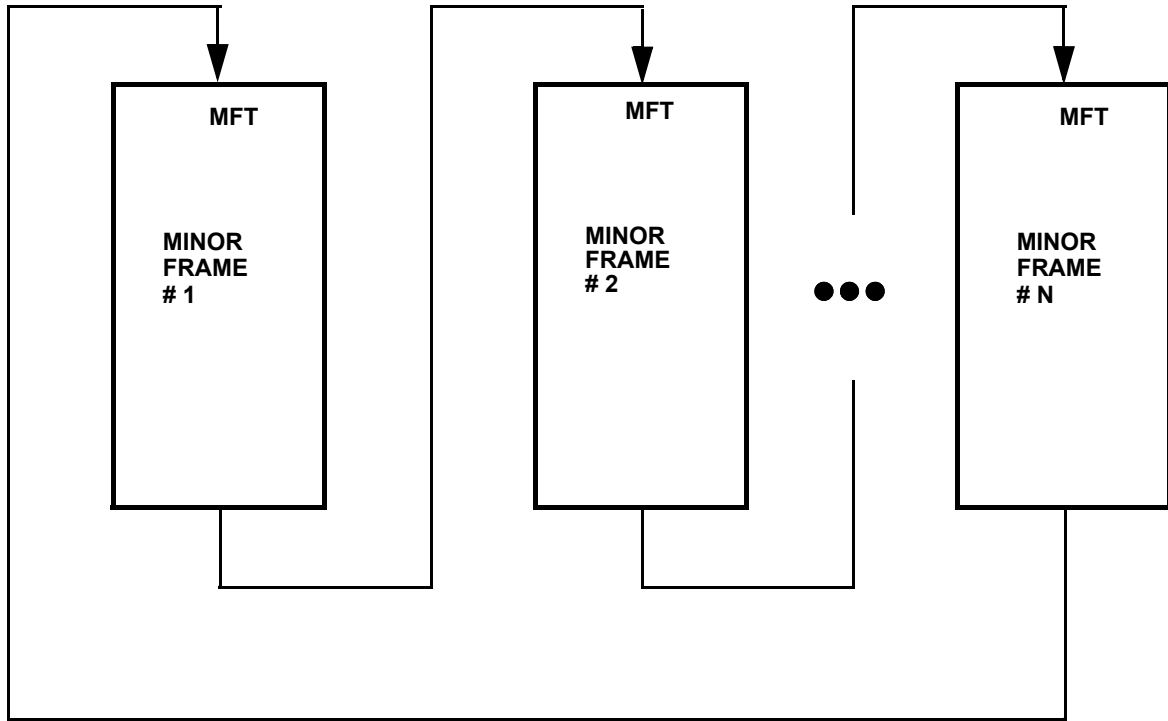

Figure 10. Major Frame Sequencing

3.4 Memory Architecture

After reviewing the SBC's internal registers, it may be advantageous to look at the external memory requirements and how the host sets up memory to make the SμMMIT a bus controller. The intent of this section is to show one method for defining the memory configuration.

The configuration shows the Command Blocks, data locations, and the Interrupt Log List as separate entities within memory. Figure 11 shows that the first block of memory is allocated for the Command Blocks. Notice that Register 8 initially points to the control word of the first Command Block. After completing execution of that first Command Block, Register 8 will automatically be updated to show the address associated with the next Command Block.

Following the Command Block locations is the memory required for all the data words. In BC applications, the number of data words for each Command Block is known. In figure 11 for example, the first Command Block has allocated several memory locations for expected data. Conversely, the second Command Block has only allocated a few memory locations. Since the number of data words associated with each Command Block is known, memory may be used efficiently.

Also, shown as a separate memory area is the Interrupt Log List (refer to section 6.0 for a description of the Interrupt Log List). Notice that Register 5 points to the top of the initial Log List. After execution of the first SBC Command Block, Register 5 will automatically be updated if interrupt condition exists.

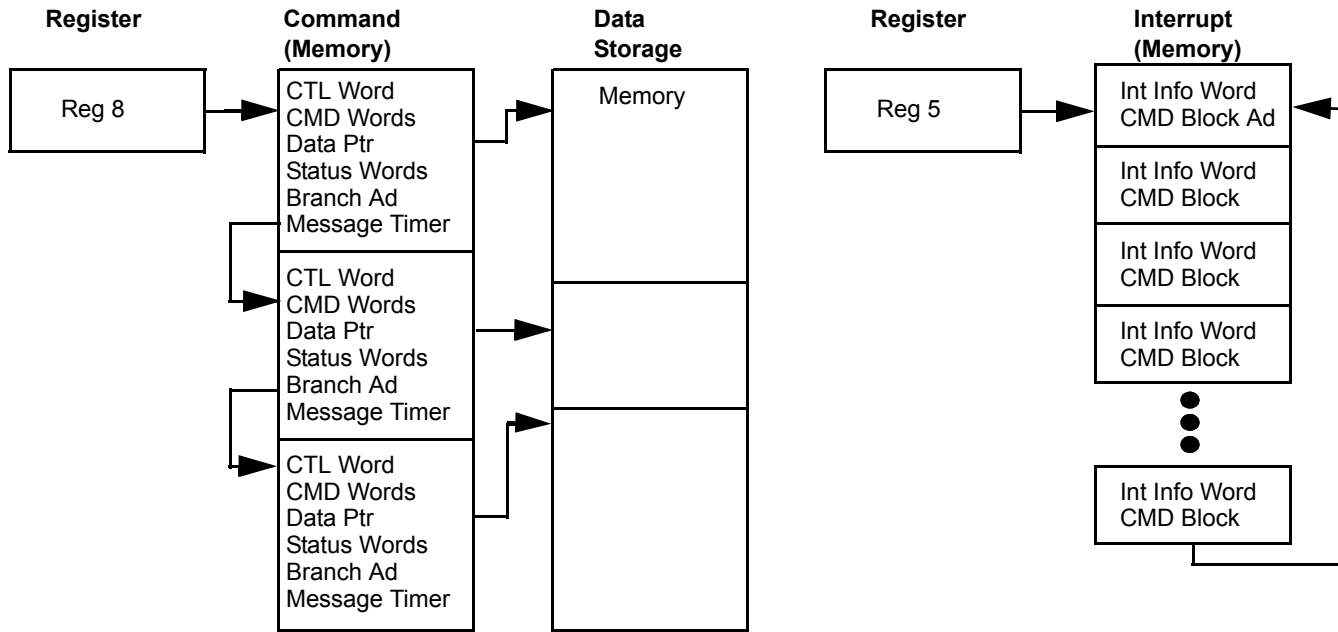

Figure 11. Memory Architecture for BC Mode

3.5 Message Processing

To process messages, the SBC uses data supplied in the internal registers along with data stored in external memory. The SBC accesses eight words stored in external memory called a command block. The command block is accessed at the beginning and end of command processing.

Note: In the SBC mode of operation, the S μ MMIT does not read the Command Block for each retry situation.

The S μ MMIT features two different modes of transferring data to or from RAM: Buffer and Non-Buffer. The user selects the Buffer or Non-Buffer transfer mode by setting the BUFR bit (bit 6) in the control register. See sections 9.1.5 or 9.2.3 for additional information.

The host or subsystem controlling the SBC allocates memory spaces for the minor frame. The top of the command blocks can reside at any address location. Defined and entered into memory by the host, the SBC is linked to the Command Block via the Command Block Pointer Register contents. Each command block contains a Control Word, Command Word 1, Command Word 2, Data Pointer, Status Word 1, Status Word 2, Branch Address, and Timer Value. Refer to sections 3.2.1 - 3.2.6 for a complete description of each location.

Control word information allows the SBC to control the commands transmitted over the 1553 bus. The Control word allows the SBC to transmit commands on a specific channel, perform retries, initiate RT-RT transfers, and interrupt on certain conditions. The host or subsystem defines each command word associated with each command block. For normal 1553 commands, only the first command word location will contain valid data. For RT-RT commands, as specified in the Control word, the host must define the first command word as a receive and the second command word as a transmit.

The SBC reads the command block during minor frame processing (i.e., after assertion of $\overline{\text{TERRACT}}$). The SBC arbitrates for the memory bus. After receiving control of the bus, the SBC reads all eight locations. The SBC then surrenders control of the bus (i.e., negates $\overline{\text{DMACK}}$), and begins the acquisition of data words for either transmission or storage.

For a receive command, the Data Pointer determines where data words are retrieved. The SBC retrieves data words sequentially from the address specified by the Data Pointer. For a transmit command, the Data Pointer determines the top memory location. The SBC stores data words sequentially from this top memory location.

After transmission or reception, the SBC begins post-processing. Command post-processing begins with the arbitration for the memory bus. The SBC performs a DMA burst during post-processing. An optional interrupt log entry is performed after a command block update. During the command block update, the SBC modifies the Control Word as required.

3.6 MIL-STD-1553A Operation

To maximize flexibility, the S μ MMIT has been designed to operate in many different systems which use various protocols. Specifically, two of the protocols that the S μ MMIT may be interfaced to are MIL-STD-1553A and MIL-STD-1553B. To meet these protocols, the S μ MMIT may be configured through an external pin or through control register bits (depending on the state of the $\overline{\text{LOCK}}$ pin).

Table 5. MIL-STD-1553A Operation

| A/B STD (pin) | RESULT |
|---------------|--------------------------------|
| 0 | 1553B response, 1553B standard |
| 1 | 1553A response, 1553A standard |

When configured as a MIL-STD-1553A bus controller, the S μ MMIT will operate as follows:

- Looks for the RT response within 9 μ s (see section 5, Enhanced S μ MMIT Family Operation);
- Defines all mode codes without data;
- Defines subaddress 00000 as a mode code.

4.0 MONITOR TERMINAL ARCHITECTURE

In many applications, the S μ MMIT Monitor Terminal (SMT) may be required to be the Backup Bus Controller (BBC). With this in mind, the SMT architecture is designed to function like the SBC's architecture. The SMT's architecture is based on a monitor block structure and internal, programmable registers. Designed to run autonomously and reduce host overhead, the SMT automatically executes data handling, message error checking, memory control, and related protocol functions. Discussed in this section are the following monitor features and functions:

- Command History List
- Executable Architecture
- BIT Capability

- Interrupt History List
- Monitor All or Selected Terminals
- Memory Management

4.1 Register Descriptions

To initialize the S μ MMIT as a monitor terminal, the designer must understand the internal registers. A complete description of each register and the associated bits is provided. These registers offer many programmable functions and allow host access to extensive information. All register bits are active high and reflect a logic zero condition (0000 hex) after Master Reset (except those reflecting input pins). Each register associated with the monitor mode of operation is described below.

| Register Number | Name | Register Address |
|-----------------|--|--------------------|
| 0 | Control Register | 0000 (hex) |
| 1 | Operational Status Register | 0001 (hex) |
| 2 | Current Command Register | 0002 (hex) |
| 3 | Interrupt Mask Register | 0003 (hex) |
| 4 | Pending Interrupt Register | 0004 (hex) |
| 5 | Interrupt Log List Pointer Register | 0005 (hex) |
| 6 | BIT Word Register | 0006 (hex) |
| 7 | Time-Tag Register | 0007 (hex) |
| 8-10 | Not Applicable | 0008 to 000A (hex) |
| 11 | Initial Monitor Command Block Pointer Register | 000B (hex) |
| 12 | Initial Monitor Data Pointer Register | 000C (hex) |
| 13 | Monitor Block Counter Register | 000D (hex) |
| 14 | Monitor Filter Register | 000E (hex) |
| 15 | Monitor Filter Register | 000F (hex) |
| 16-31 | Not Applicable | 0010 to 001F (hex) |

Note: Reference section 9.1.2 for S μ MMIT XT 8-bit register address numbers.

4.1.1 Control Register (Read/Write) - Register 0

To operate the S μ MMIT as a monitor terminal, use the following bits. To make changes to the SMT and this register, the STEX bit (Bit 15) must be logic zero.

Note: The user has 5 μ s after $\overline{\text{TERACT}}$ active to stop execution.

| Bit Number | Mnemonic | Description |
|------------|----------|---|
| 15 | STEX | Start Execution. Assertion of this bit commences operation of the S μ MMIT. A Control Register write negating this bit inhibits operation of the S μ MMIT. After execution has begun, a write of a logic zero will halt the SMT after completing the current 1553 message. |
| 14 | SBIT | Start BIT. Assertion of this bit places the S μ MMIT into the Built-In Test routine. The BIT test has a 93.4% fault coverage. If the S μ MMIT has been started, the host must halt the device in order to place the S μ MMIT into the Built-In Test routine (STEX = 0). Note: If Start BIT (SBIT) and Start Execution (STEX) are both set on one register write, BIT has priority. |
| 13 | SRST | Software Reset. Assertion of this bit immediately places the S μ MMIT into a software reset. The software <u>reset</u> (which takes 5 μ s to execute) clears all internal logic, just as the MRST does. Note: During auto-initialization, do not load this bit with a logic one. SRST will only function after $\overline{\text{READY}}$ is asserted. |
| 12-11 | N/A | Not Applicable. |
| 10 | ETCE | External Timer Clock Enable. If this bit is set to logic one, the SMT will use the external input clock to drive the Time-Tag counter. If set to logic zero, the SMT will use an internal clock to drive the time tag counter. Refer to section 4.1.8 for additional information. Note: The user can only change the clock frequency before starting the device (i.e., setting bit 15 of Register 0 to a logic one). |
| 9 | -- | See section 5, Enhanced S μ MMIT Family Operation. |
| 8-7 | N/A | Not Applicable. |
| 6 | BUFR | Buffer Mode Enable. Assertion of this bit enables the buffer mode of operation. For more detailed information on this feature refer to section 9.1.5 and 9.2.3. |
| 5 | SMTC | Monitor Control. This bit determines whether the SMT will monitor all RTs or selected RTs. If this bit is set to logic zero, the SMT will monitor all RTs. If this bit is set to logic one, the SMT will monitor only the RTs as specified in the Monitor Filter Registers (Registers 14 and 15). |
| 4 | BCEN | Broadcast Enable. This bit, if set to logic one, allows RT address 31 to be used as a Broadcast message. If set to logic zero, then address 31 is a normal address. |
| 3-2 | N/A | Not Applicable. |
| 1 | INTEN | Interrupt Log List Enable. Assertion of this bit enables the Interrupt Log List. Negation of this bit prevents the logging of interrupts as they occur. |
| 0 | N/A | Not Applicable. |

4.1.2 Operational Status Register (Read/Write) - Register 1

This register reflects pertinent status information for the SMT and is not reset to 0000 (hex) on $\overline{\text{MRST}}$. Instead, the register reflects the actual stimulus applied to input pins MSEL(1:0), $\text{A}/\overline{\text{B}}$ STD, and $\overline{\text{LOCK}}$. Assertion of the $\overline{\text{LOCK}}$ input prevents the modification of the remote terminal address, mode selects, and the A or B Standard bits. In this case, a write to this register's most significant nine bits is meaningless. If $\overline{\text{LOCK}}$ is negated, a read of this register reflects the information written into this register's most significant nine bits.

Note: To make changes to the SMT and this register, the STEX bit (Register 0, bit 15) must be logic zero.

| Bit Number | Mnemonic | Description | | | | | | | | | | | | | | | |
|------------|------------------------------------|--|---------|---------|-------------------|---|---|----------------------|---|---|-----------------------|---|---|------------------------|---|---|---------|
| 15-10 | N/A | Not Applicable. | | | | | | | | | | | | | | | |
| 9 | MSEL(1) | Mode Select 1. In conjunction with Mode Select 0, this bit determines the S μ MMIT mode of operation. | | | | | | | | | | | | | | | |
| 8 | MSEL(0) | Mode Select 0. In conjunction with Mode Select 1, this bit determines the S μ MMIT mode of operation. | | | | | | | | | | | | | | | |
| | | <table border="1"> <thead> <tr> <th>MSEL(1)</th> <th>MSEL(0)</th> <th>Mode of Operation</th> </tr> </thead> <tbody> <tr> <td>0</td> <td>0</td> <td>Bus Controller = SBC</td> </tr> <tr> <td>0</td> <td>1</td> <td>Remote Terminal = SRT</td> </tr> <tr> <td>1</td> <td>0</td> <td>Monitor Terminal = SMT</td> </tr> <tr> <td>1</td> <td>1</td> <td>SMT/SRT</td> </tr> </tbody> </table> | MSEL(1) | MSEL(0) | Mode of Operation | 0 | 0 | Bus Controller = SBC | 0 | 1 | Remote Terminal = SRT | 1 | 0 | Monitor Terminal = SMT | 1 | 1 | SMT/SRT |
| MSEL(1) | MSEL(0) | Mode of Operation | | | | | | | | | | | | | | | |
| 0 | 0 | Bus Controller = SBC | | | | | | | | | | | | | | | |
| 0 | 1 | Remote Terminal = SRT | | | | | | | | | | | | | | | |
| 1 | 0 | Monitor Terminal = SMT | | | | | | | | | | | | | | | |
| 1 | 1 | SMT/SRT | | | | | | | | | | | | | | | |
| 7 | $\text{A}/\overline{\text{B}}$ STD | Military Standard 1553A or 1553B Standard. This bit determines whether the SMT will look for the RT's response in 9 μ s (MIL-STD-1553A) or in 15 μ s (MIL-STD-1553B). Assertion of this bit forces the SMT to declare a time-out error condition if the RT has not responded in 9 μ s. Negation of this bit allows the SMT to declare a time-out error condition if the RT has not responded in 15 μ s. See section 4.7 and section 5.0, Enhanced S μ MMIT Family Operation, for additional information. | | | | | | | | | | | | | | | |
| 6 | $\overline{\text{LOCK}}$ | $\overline{\text{LOCK}}$ Pin. This read-only bit reflects the inverted state of the $\overline{\text{LOCK}}$ input pin. The Lock pin is latched on the rising edge of $\overline{\text{MRST}}$. If modes of operation must change, the user must perform a $\overline{\text{MRST}}$. | | | | | | | | | | | | | | | |
| 5 | $\overline{\text{AUTOEN}}$ | $\overline{\text{AUTOEN}}$ Pin. This read-only bit defines whether or not the auto enable feature will be used in the design. This bit shows the inverse of the auto enable ($\overline{\text{AUTOEN}}$) input pin. | | | | | | | | | | | | | | | |
| 4 | N/A | Not Applicable. | | | | | | | | | | | | | | | |
| 3 | EX | S μ MMIT Executing. This read-only bit indicates whether the SMT is presently executing or whether it is idle. A logic one indicates that the S μ MMIT is executing, logic zero idle. | | | | | | | | | | | | | | | |
| 2 | N/A | Not Applicable. | | | | | | | | | | | | | | | |
| 1 | $\overline{\text{READY}}$ | $\overline{\text{READY}}$ Pin. This read-only bit reflects the inverted state of the output pin $\overline{\text{READY}}$ and is cleared on reset. | | | | | | | | | | | | | | | |
| 0 | TERACT | Terminal Active Pin. Assertion of this bit indicates that the SMT is presently processing a message. This read-only bit reflects the inverted state of output pin TERACT and is cleared on reset. | | | | | | | | | | | | | | | |

4.1.3 Current Command Register (Read-only) - Register 2

This register contains the last valid command that was transmitted over the 1553 bus. In a RT-RT transfer, this register will update as each of the two commands are received by the SMT.

| Bit Number | Mnemonic | Description |
|-------------------|-----------------|--|
| 15-0 | CC(15:0) | Current Command. These bits contain the latest 1553 word that was received by the SMT. |

4.1.4 Interrupt Mask Register (Read/Write) - Register 3

The SMT interrupt architecture allows the host or subsystem to mask or temporarily disable the service of interrupts. While masked, interrupt activity does not occur. The unmasking of an interrupt after the event occurs does not generate an interrupt for that event. An interrupt is masked if the corresponding bit of this register is set to logic zero.

| Bit Number | Mnemonic | Description |
|-------------------|-----------------|----------------------------------|
| 15 | DMAF | DMA Fail Interrupt. |
| 14-13 | N/A | Not Applicable. |
| 12 | BITF | BIT Fail Interrupt. |
| 11 | MERR | Message Error Interrupt. |
| 10-1 | N/A | Not Applicable. |
| 0 | MBC | Monitor Block Counter Interrupt. |

4.1.5 Pending Interrupt Register (Read-only) - Register 4

The Pending Interrupt Register contains information that identifies events that generate interrupts. The assertion of any bit in this register asserts an output pin, $\overline{\text{MSG_INT}}$ or $\overline{\text{YF_INT}}$ (three clock cycles). Writing to the most significant four bits of this register generates a $\overline{\text{YF_INT}}$.

| Bit Number | Mnemonic | Description |
|------------|----------|--|
| 15 | DMAF | DMA Fail Interrupt. Once the S μ MMIT has issued the $\overline{\text{DMAR}}$ signal, an internal timer is started. If all DMA activity has not been completed, the interrupt is generated (if not masked). In the SMT mode, the $\overline{\text{YF_INT}}$ interrupt is generated, current command processing will end, and the SMT will remain on-line. |
| 14-13 | N/A | Not Applicable. |
| 12 | BITF | BIT Fail Interrupt. Assertion of this bit indicates a BIT failure. Interrogate the BIT Word Register to determine the specific failure. $\overline{\text{YF_INT}}$ interrupt generated (if not masked), operation continues. |
| 11 | MERR | Message Error Interrupt. This bit is set if a message error occurs. The SMT can detect Manchester, sync-field, word count, 1553 word parity, bit count, and protocol errors. This bit will be set and interrupt generated after message processing is complete. $\overline{\text{MSG_INT}}$ interrupt generated (if not masked). |
| 10-1 | N/A | Not Applicable. |
| 0 | MBC | Monitor Block Counter Interrupt. This bit is set if the SMT's monitor block counter reaches zero (transition from 1 to 0). It should be noted that the SMT does not discriminate between error-free messages and those messages with errors. $\overline{\text{MSG_INT}}$ interrupt generated (if not masked). |

Note: The user must read or write a S μ MMIT register after reading the Pending Register to invoke the automatic clear of the Pending Interrupt Register. For example, a Subaddress Access interrupt results in a Pending Interrupt Register of 0400₁₆. A read of the Pending Interrupt Register returns a value of 0400₁₆. A subsequent read of the Interrupt Mask Register (i.e., Register 3₁₆), followed by a Pending Interrupt Register read returns a value of 0000₁₆. The intervening read of the Interrupt Mask Register clears of the Pending Interrupt Register at the end of the Interrupt Mask Register read.

4.1.6 Interrupt Log List Pointer Register (Read/Write) - Register 5

This register indicates the starting address of the Interrupt Log List. The Interrupt Log List is a 32-word ring-buffer that contains information pertinent to the service of interrupts. The S μ MMIT architecture requires the location of the Interrupt Log List on a 32-word boundary. The most significant 11 bits of this register designate the location of the Interrupt Log List within a 32K memory space. Initialize the lower five bits of this register to a logic zero. The S μ MMIT controls the lower five bits to implement the ring-buffer architecture. The host or subsystem reads this register to determine the location and number of interrupts within the Interrupt Log List (least significant five bits).

| Bit Number | Mnemonic | Description |
|------------|------------|---|
| 15-0 | INTA(15:0) | Interrupt Log List Pointer Bits. These bits indicate the starting location of the Interrupt Log List. |

4.1.7 BIT Word Register (Read/Write)- Register 6

This register contains information on the current health of the SMT. The lower eight bits of this register are user-defined.

| Bit Number | Mnemonic | Description |
|------------|----------|---|
| 15 | DMAF | DMA Fail. This bit is set if all DMA activity has not been completed between the time $\overline{\text{DMAR}}$ asserts and when the timer decrements to zero. The DMA activity includes $\overline{\text{DMAR}}$ to $\overline{\text{DMAG}}$ and all wait states. In the event of a DMA failure, current message processing terminates; monitor terminal waits for next 1553 message. DMAF asserts, and $\overline{\text{YF_INT}}$ is generated (if not masked). |
| 14-13 | N/A | Not Applicable. |
| 12 | BITF | BIT Fail. Assertion of this bit indicates a BIT failure. Interrogate bits 11 through 8 to determine the specific failure. |
| 11 | CHAF | Channel A Fail. Assertion of this bit indicates a BIT test failure in Channel A. |
| 10 | CHBF | Channel B Fail. Assertion of this bit indicates a BIT test failure in Channel B. |
| 9 | MSBF | Memory Test Fail. Most significant memory byte failure ($\text{S}\mu\text{MMIT XTE}$). User-Defined Bits ($\text{S}\mu\text{MMIT E}$ & $\text{S}\mu\text{MMIT LXE/DXE}$). |
| 8 | LSBF | Memory Test Fail. Least significant memory byte failure ($\text{S}\mu\text{MMIT XTE}$). User-Defined Bits ($\text{S}\mu\text{MMIT E}$ & $\text{S}\mu\text{MMIT LXE/DXE}$). |
| 7-0 | UDB(7:0) | User-Defined Bits. |

4.1.8 Time-Tag Register (Read/Write) - Register 7

This register reflects the state of a 16-bit free running ring counter. This counter will remain a free running counter as long as the device is not in $\overline{\text{MRST}}$ or in a software reset state. The resolution of this counter is user-defined via input $\overline{\text{TCLK}}$ or fixed at a period of 64 μs . The Time-Tag counter begins operation on the rising edge to $\overline{\text{MRST}}$.

| Bit Number | Mnemonic | Description |
|------------|----------|--|
| 15-0 | TT(15:0) | Time-Tag Counter Bits. These bits indicate the state of the 16-bit internal counter. |

4.1.9 Initial Monitor Block Pointer Register (Read/Write) - Register 11

This register contains the starting location of the monitor blocks.

Note: It is recommended that this register not be changed while the SMT is active (i.e., Register 1, bit 3 = 1).

| Bit Number | Mnemonic | Description |
|------------|-----------|--|
| 15-0 | MBA(15:0) | Initial Monitor Block Address. These bits indicate the starting location of the monitor block. |

4.1.10 Initial Monitor Data Pointer Register (Read/Write) - Register 12

This register contains the starting location of the monitor data.

Note: It is recommended that this register not be changed while the SMT is active (i.e., Register 1, bit 3 = 1).

| Bit Number | Mnemonic | Description |
|-------------------|-----------------|--|
| 15-0 | MDA(15:0) | Initial Monitor Data Address. These bits indicate the starting location of the monitor data. |

4.1.11 Monitor Block Counter Register (Read/Write) - Register 13

This register contains the number of the monitor block the user wishes to log. After execution begins, this register automatically decrements as commands are logged. When this register is decremented from one to zero, an interrupt will be generated, if enabled. The SMT will start over at the initial pointers as identified in Registers 11 and 12.

Note: It is recommended that this register not be changed while the SMT is active (i.e., Register 1, bit 3 = 1).

| Bit Number | Mnemonic | Description |
|-------------------|-----------------|---|
| 15-0 | MBC(15:0) | Monitor Block Count. These bits indicate the number of monitor blocks to log. |

4.1.12 Monitor Filter Register (Read/Write) - Register 14

This register determines which RTs (RT 31 through RT 16) the SMT will monitor. Reset value is 0000 (hex). A logical "1" indicates the monitor captures all data to and from the remote terminal.

| Bit Number | Mnemonic | Description |
|-------------------|-----------------|---|
| 15-0 | MF(31:16) | Monitor Filter. These bits determine which RT to monitor. |

4.1.13 Monitor Filter Register (Read/Write) - Register 15

This register determines which RTs (RT 15 through RT 0) the SMT will monitor. Reset value is 0000 (hex). A logical "1" indicates the monitor captures all data to and from the remote terminal.

| Bit Number | Mnemonic | Description |
|-------------------|-----------------|---|
| 15-0 | MF(15:0) | Monitor Filter. These bits determine which RT to monitor. |

4.2 SMT Architecture

To meet the MIL-STD-1553 monitor requirements, the SMT utilizes a monitor block architecture that takes advantage of both internal registers and external memory. The monitor block, which is located in external contiguous memory, requires eight locations for each message. These eight locations include a message information word, two command word locations, a data pointer, two status word locations, a time-tag location, and an unused location.

The host, or ROM for autonomous operation, must initialize the starting locations of the monitor block, the Data Pointer, Block Counter, and the Interrupt Log Pointer. From then on, the SMT will build a monitor block for each message it receives over the 1553 bus. Figure 11 shows a diagram of the monitor block followed by a description of each location associated with the monitor block.

The first memory location of each monitor block contains the message information word. Each message information word contains the opcode, retry number, bus definition, RT-RT messages, and the message information.

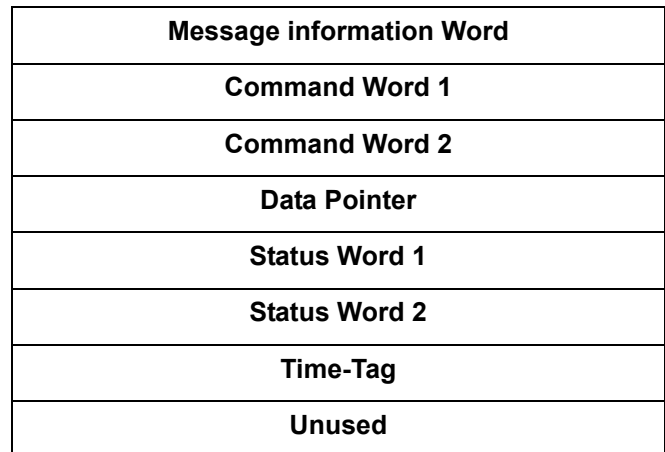
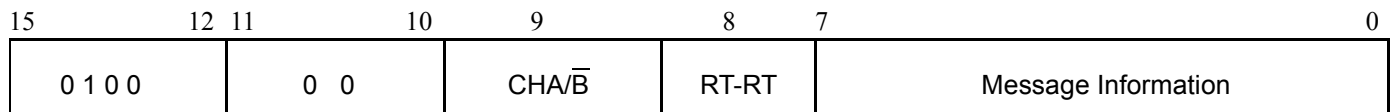

Figure 12. Monitor Block Diagram



4.2.1 Message Information Word

| Bit Number | Description |
|------------|--|
| 15-12 | Default. With the monitor block architecture resembling the SBC Command Block architecture, these bits default to a "0100" state (which is the Execute and Continue opcode) in case the monitor must switch to the BC mode of operation. |
| 11-10 | Default. With the monitor block architecture resembling the SBC, these bits default to a "00" state. If the monitor must switch to the BC, the retries will be set at four per message. |
| 9 | Channel A/ \bar{B} . This bit defines on which of the two buses the command was received. (Logic 1 = Bus A, Logic 0 = Bus B). |
| 8 | RT-RT Transfer. This bit defines whether or not the message associated with this monitor block was a RT-RT transfer and whether the SMT saved the second command word. This bit will be set only if the SMT is instructed to monitor the Receive RT. |
| 7-0 | Message Information. These bits define the conditions of the message received by the SMT for that particular monitor block. Each of the message information bits is defined in the following section. |

4.2.1.1 Message Information Bits

Message information bits are provided as a means to supply more data on the message. In a RT-RT transfer, the information applies to the complete message. Each message information bit is defined below.

| Bit Number | Description |
|-------------------|--|
| 7 | Message Error. This bit will be set if the monitor detects an error in either the command word, data words, or the RT's status. |
| 6 | Mode Code without Data. This bit will be set if the monitor detects that the command being processed is a mode code without data words. |
| 5 | Broadcast. This bit will be set if the monitor detects that the command being processed is a broadcast message. |
| 4 | Reserved. |
| 3 | Time-out Error. This bit will be set if the SRT did not receive the proper number of data words, e.g., the number of data words received was less than the word count specified in the command word. |
| 2 | Overrun Error. This bit will be set if the SRT received a word when none were expected or the number of data words received was greater than expected. |
| 1 | Parity Error. This bit will be set if a parity error has occurred on the data words or the RT's status word. |
| 0 | Manchester Error. This bit will be set if a Manchester error has occurred on either the data words or the RT's status word. |

4.2.2 Command Words

The next two locations in the SMT monitor block are for command words. In non-RT-RT 1553 messages, only the first command word will be stored. However, in a RT-RT transfer, the first command word is the Receive Command and the second command word is the Transmit Command.

4.2.3 Data Pointer

The fourth location in the SMT monitor block is the data pointer. This pointer points to the first memory location to store the data words associated with the message for this block. Note that the data associated with each individual message will be stored contiguously. This data structure allows the SMT to store the specified number of data words. (Note: In a RT-RT transfer, the SMT uses the data pointer as the location in memory to store the transmitting data in the transfer.)

4.2.4 Status Words

The next two locations in the SMT monitor block are for status words. As the RT responds to the BC's command, the corresponding status word will be stored in Status Word 1. However, in a RT-RT transfer, the first status word will be the status of the Transmitting RT while the second status word will be the status of the Receiving RT.

4.2.5 Time-Tag

The seventh location in the SMT monitor block is the time-tag associated with the message. The time-tag is stored into this location at the end of message processing (i.e., captured after the command is validated).

4.2.6 Unused

The last location in the SMT monitor block is unused.

4.3 Monitor Block Chaining

The host determines the first monitor block by setting the start address in the initial monitor block Pointer Register (Register 11). Figure 13 shows the SMT monitor blocks as the blocks execute in a contiguous fashion (monitor block count Register 13 = 5).

4.4 Memory Architecture

Figure 14 shows the monitor blocks, data locations, and the Interrupt Log List as separate entities within memory. The configuration shows that the first block of memory is allocated for the monitor blocks. Notice that Register 11 points to the initial monitor block location, Register 12 points to the initial Data location, Register 5 points to the Interrupt Log, and Register 13 contains the monitor block count. After execution begins, the SMT will build command blocks and store data words until the count reaches zero. When the count reaches zero, the SMT will simply wrap back to the initial values and start again.

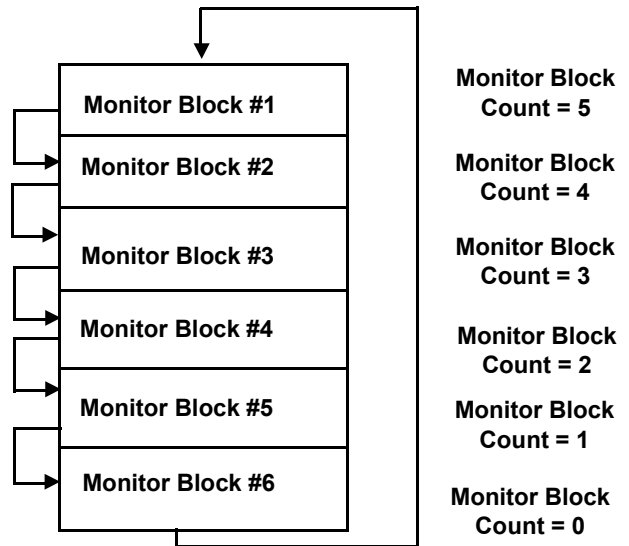

Figure 13. Monitor Block Structuring

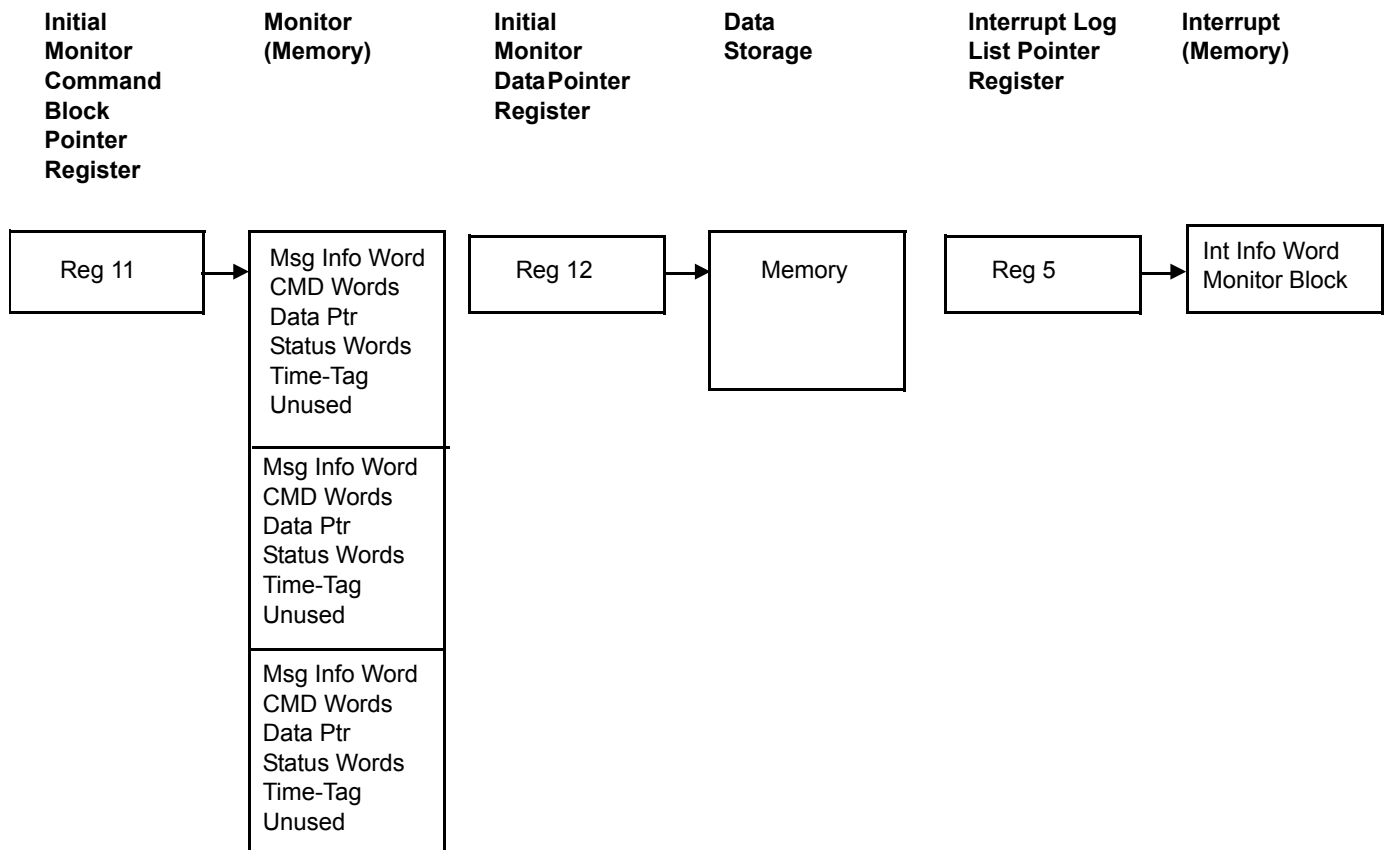

Figure 14. Memory Architecture for Monitor Mode

4.5 Message Processing

To process messages, the SMT uses data supplied in the internal registers along with external memory. The SMT uses eight external memory locations for each message called a monitor block. The monitor block is updated at the end of command processing. The following paragraphs discuss the monitor block in detail.

The S μ MMIT features two different modes of transferring data to RAM: Buffer and Non-Buffer. The user selects the Buffer or Non-Buffer transfer mode by setting the BUFR bit (bit 6) in the Control Register. See sections 9.1.5 or 9.2.3 for additional information.

The host or subsystem controlling the SMT allocates memory spaces for each monitor block. The top of the monitor blocks can reside at any address location. Initialized by the host, the SMT is linked to the monitor block via the initial monitor block Pointer Register and the Monitor Block Counter Register contents. Each monitor block contains a Message Information Word, Command Word 1, Command Word 2, Data Pointer, Status Word 1, Status Word 2, and Time-Tag. Refer to sections 4.2.1 - 4.2.6 for a full description of each location.

The Message Information word allows the SMT to tell the host or subsystem on which bus the command was received, whether the message was a RT-RT transfer, and conditions associated with the message. The SMT also stores each command word associated with the message into the appropriate location. For normal 1553 commands, only the first command word location will contain data. For RT-RT commands, the second command word location will contain data, and bit 8 in the Message Information word will be set.

For each command, the Data Pointer determines where to store data words. The SMT stores data sequentially from the top memory location. The SMT also stores each status word associated with the message into the appropriate location. For normal 1553 commands, only the first status word location will contain data. For RT-RT commands, the second status word location will contain data. The SMT begins monitoring after Control Register bit 15=1 (i.e., assertion of STEX).

After reception, the SMT begins post-processing. The SMT performs a DMA burst during post-processing. An optional interrupt log entry is performed after a monitor block is entered. Monitor Time-Out:

MIL-STD-1553A = 9 μ s
MIL-STD-1553B = 15 μ s

See section 5, Enhanced S μ MMIT Family Operation for additional information.

4.5.1 Error Condition Message Processing

When the monitor detects an error condition in either the command word, data words, or the RT's status, the monitor block will not store the data. The monitor block counter increments. The initial message data pointer remains constant. The monitor block pointer increments. Message information bits of the monitor block are changed to reflect the error. An interrupt is given indicating a message has occurred. See section 4.2.1.1 for additional information.

4.6 Remote Terminal/Monitor Terminal Operation

For applications that require simultaneous Remote Terminal and Monitor Terminal operations, the S μ MMIT should be configured as both a remote terminal (SRT) and monitor terminal (SMT). This feature allows the SRT to communicate on the bus for one specific address and the SMT to monitor the bus for other specific addresses. Configuration as both SMT and SRT precludes the S μ MMIT from monitoring its own remote terminal address.

When the S μ MMIT is configured as both SRT and SMT, the SRT has priority over the SMT. For example, commands to the SRT will always take priority over monitoring functions for the SMT. The examples below describe what happens if the SRT is defined as terminal address 1 and the SMT is to monitor terminal address 12.

Example 1:

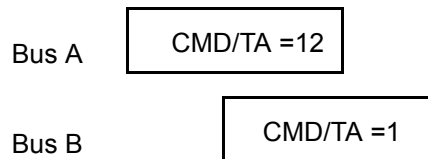

In this example, the SMT will decode the first command on bus A, realize the message is for terminal address 12, and start monitoring the message. However, as soon as the SRT realizes the second command on bus B is to terminal address 1, the SRT will take priority and begin SRT message processing.

Example 2:

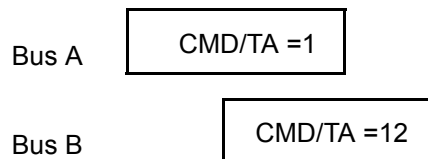

In example 2, the SRT will decode the first command on bus A, realize the message is for terminal address 1, and start message processing. As the message on bus B is received, the S μ MMIT will realize it is to terminal address 12, but since the SRT has priority the SMT will not switch to the monitor mode.

The above examples also apply to a RT-RT message. For example, if the first command in a RT-RT transfer matches the terminal address of the SRT, the entire message will be processed by the SRT (Message 1). However, if the first command in a RT-RT transfer matches the terminal address of the SMT and the second command matches the terminal address of the SRT, the SRT will take priority and process the message (Message 2). Below is a RT-RT message example.

| | | |
|-----------|------------|------------|
| Message 1 | CMD/TA =1 | CMD/TA =12 |
| Message 2 | CMD/TA =12 | CMD/TA =1 |

4.7 MIL-STD-1553A Operation

To maximize flexibility, the S μ MMIT has been designed to operate in many different systems which use various protocols. Specifically, two of the protocols that the S μ MMIT may be interfaced to are MIL-STD-1553A and MIL-STD-1553B. To meet these protocols, the S μ MMIT may be configured through an external pin or through control register bits (depending on the state of the LOCK pin).

Table 6. MIL-STD-1553A Operation

| A/B STD (pin) | RESULT |
|---------------|--------------------------------|
| 0 | 1553B response, 1553B standard |
| 1 | 1553A response, 1553A standard |

When configured as a MIL-STD-1553A monitor, the S μ MMIT will operate as follows:

- Looks for the RT response within 9 μ s (see section 5, Enhanced S μ MMIT Family Operation);
- Defines all mode codes without data;
- Defines subaddress 00000 as a mode code.

5.0 ENHANCED S μ MMIT FAMILY OPERATION

The following describes the Enhanced S μ MMIT features.

5.1 Message Time-out

Programmable bus controller and monitor time-out feature allows for the implementation of extended buses. Bit 9 of the Control Register determines the remote terminal no response time period. During MIL-STD-1553B operation, the programmable time-out occurs at either 14 μ s or 30 μ s. In MIL-STD-1553A mode, time-out occurs at either 9 μ s or 21 μ s. See Figure 15.

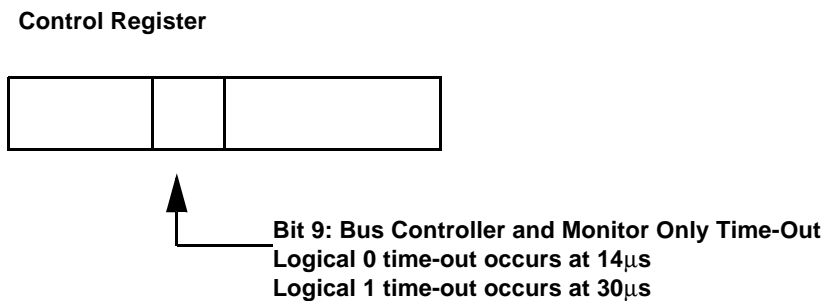

Figure 15. Programmable Bus Controller Time-Out

5.2 DMA Time-out

DMA time-out, in the bus controller mode of operation, is 16 μ s (t_b , t_a). The S μ MMIT architecture times all DMA cycles to ensure that memory access timing supports message processing. Excessive memory access delays result in a DMA time-out condition. In the event of DMA time-out, the S μ MMIT ceases message processing and generates an interrupt if enabled. The S μ MMIT E and S μ MMIT LXE/DXE specify the DMA time-out period per AC Electrical Characteristic t_b . The S μ MMIT XTE specifies the DMA time-out per AC Electrical Characteristic t_a . See figure 38 for t_b and figure 50 for t_a .

5.3 Circular Buffers

The S μ MMIT family circular buffer simplifies the software service of remote terminals implementing bulk or periodic data transfers. The Enhanced S μ MMIT architecture allows the user to select one of two circular buffer modes. The user selects the preferred mode, at start-up, by writing to Control Register bits 7 and 8. The Control Register bits allow for the decode of three unique modes. Table 7 reviews mode selections.

Table 7. Enhanced Mode of Operation

| Mode Number | Bit 7 | Bit 8 |
|-------------|-------|-------|
| 0 | 0 | 0 |
| 1 | 0 | 1 |
| X | 1 | 0 |
| 2 | 1 | 1 |

5.3.1 Mode Number 0

Remote Terminal Index or Ping-Pong Operation, non-Enhanced S μ MMIT, the user programs bits 7 and 8 to logical zero. Operation is per sections 2.2 and 2.3 (default state).

5.3.2 Mode Number 1

Remote Terminal Buffer 1, Enhanced S μ MMIT operation, the user programs bit 7 to 0 and bit 8 to 1. The S μ MMIT merges transmit or receive data into a circular buffer along with message information. For each valid receive message, the S μ MMIT enters a message information word, time-tag word, and data word(s) into a unique receive circular buffer. For each valid transmit message, the S μ MMIT enters a message information word and time-tag word into reserved memory locations within the transmit circular buffer. The S μ MMIT automatically controls the wrap around of circular buffers.

Two pointers define circular buffer length: top of buffer and bottom of buffer. User specifies the top of buffer (i.e., top address (TA_{16})) by writing a value into the second word of a unique mode code or subaddress descriptor block. The user defines the bottom of the buffer (i.e., bottom address (BA_{16})) by writing to the fourth word of that unique descriptor block. Both the TA_{16} and BA_{16} remain static during message process-

ing. The third word in the descriptor block identifies the current address (i.e., last accessed address plus one). The circular buffer wraps to the top address after completing a message that results in CA_{16} being greater than or equal to BA_{16} . If CA_{16} increments past BA_{16} during intra-message processing, the S μ MMIT will access memory (read or write) address locations past BA_{16} . Delimit all circular buffer boundaries with at least 34 address locations.

Each subaddress and mode code, both transmit and receive, has a unique circular buffer assignment. The S μ MMIT decodes the command word T/R bit, subaddress/mode field, and word count/mode code field to select a unique descriptor block which contains TA_{16} , CA_{16} , and BA_{16} .

For receive messages, the S μ MMIT stores the message information word into address location CA_{16} , the time-tag word into $CA_{16} + 1_{16}$, and the data into the next " N_{16} " locations starting at address $CA_{16} + 2_{16}$. For each transmit command, the S μ MMIT stores the message information word into address location CA_{16} and time-tag word into location $CA_{16} + 1_{16}$. Retrieval of data for transmission starts at address location $CA_{16} + 2_{16}$. When entering multiple transmit command data packets into the circular buffer, delimit each data packet with two reserved memory locations. The S μ MMIT enters the message information word and time-tag word into the delimiting memory locations.

5.3.3 Mode Number 2

Circular Buffer 2, enhanced S μ MMIT operation, the user programs Control Register bit 7 to 1 and bit 8 to 1. The S μ MMIT separates message data and message information into unique circular buffers. The separation of data from message information simplifies the software that loads and unloads data from the buffers. Each subaddress and mode code, both transmit and receive, has a unique pair of circular buffers. The S μ MMIT decodes the command word T/\bar{R} bit, subaddress/mode field, and word count/mode code field to select a unique descriptor block which contains TA_{16} , CA_{16} , and Message Information Buffer (MIB).

Control the wrap-around of both the data and message circular by specifying the number of messages before wrap-around occurs. The second word entered into the descriptor block determines the top of the data buffer (TA_{16}). The third word in the descriptor block identifies the current position (CA_{16}) in the buffer (i.e., last accessed address plus one). The fourth word in the descriptor block identifies the MIB's starting location and current position. The MIB contains Time-Tag and Message Information words for each message transacted on the bus. The data buffer and message information word buffer wrap around after processing a pre-determined number of

messages. Each subaddress and mode code, both transmit and receive, has a unique data buffer and MIB assignment.

5.4 Ping-Pong Handshake

The Enhanced S μ MMIT provides a software handshake which indicates the enable and disable of buffer ping-pong operation. During remote terminal operation, the S μ MMIT asynchronous ping-pongs between two subaddress or mode code data buffers. To perform buffer service, the application software must freeze the remote terminal's access to a single buffer. The S μ MMIT's ping-pong enable/disable handshake allows the application software to asynchronously freeze (i.e., disable ping-pong operation) the remote terminal to a single buffer.

5.5 Circular Buffer Mode #1

To implement Circular Buffer 1's architecture, the four word descriptor block and Control Register are different than in the mode #0. Bits 15 through 8 of the Control Word are don't care. The second word of the descriptor block defines the buffer's starting or top address (TA_{16}). The TA pointer remains static during message processing. The fourth entry into the descriptor block identifies the buffer's bottom address (i.e., BA_{16}) and also remains static during message processing. The third descriptor block word represents the current address (i.e., CA_{16}) in the buffer and is dynamic. If the S μ MMIT observes no message error conditions, the CA_{16} pointer updates at the end of message processing. The application software reads the dynamic CA_{16} pointer to determine the current bottom of the buffer.

First, a review of receive message processing. The S μ MMIT begins all message processing by reading a unique descriptor block after reception and validation of a subaddress or mode code command word. The S μ MMIT internally increments the CA_{16} pointer to store the receive data word(s). After message processing completes, the S μ MMIT stores the message information word and time-tag word into the circular buffer preceding the message data. At the end of message processing, the S μ MMIT updates CA_{16} (if no errors detected). For CA_{16} larger than BA_{16} storage of the next message begins at the address location pointed to by the TA_{16} pointer, and CA_{16} is made equal to TA_{16} . If CA_{16} is less than BA_{16} , CA_{16} points to the next available memory location in the buffer (i.e., $CA_{16} + 1$).

For transmit commands, the S μ MMIT begins transmission of data from memory location $CA_{16} + 2_{16}$. Reserve the first two locations for the message information word and time-tag word. After message processing completes, the S μ MMIT enters the message information word and time-tag word into the circular buffer. At the end of message processing, the S μ MMIT updates CA_{16} (if no errors detected). For CA_{16}

larger than BA_{16} , storage of the next message begins at the address location pointed to by the TA_{16} pointer, and CA_{16} is made to equal TA_{16} . If CA_{16} is less than BA_{16} , CA_{16} points to the next available memory location in the buffer (i.e. $CA_{16} + 1$).

In this mode of operation, bits INDX, NII and A/B of the Descriptor Control Word and the PPEN bit of the Control Register are don't care. Message information word bit 5 reflects the reception of broadcast message via the BRD bit.

The $S_{\mu}MMIT$ generates a circular buffer empty/full interrupt when the buffer reaches the end (i.e., CA_{16} greater than BA_{16}) and begins a new message at the top of the buffer. Bit 8 of the Mask Register and bit 7 of the Descriptor Control Word mask enables the generation of the Full/Empty interrupt. On the occurrence of either interrupt, the MSG_INT output asserts. Figure 16 describes the relationship between TA_{16} , BA_{16} , and CA_{16} .

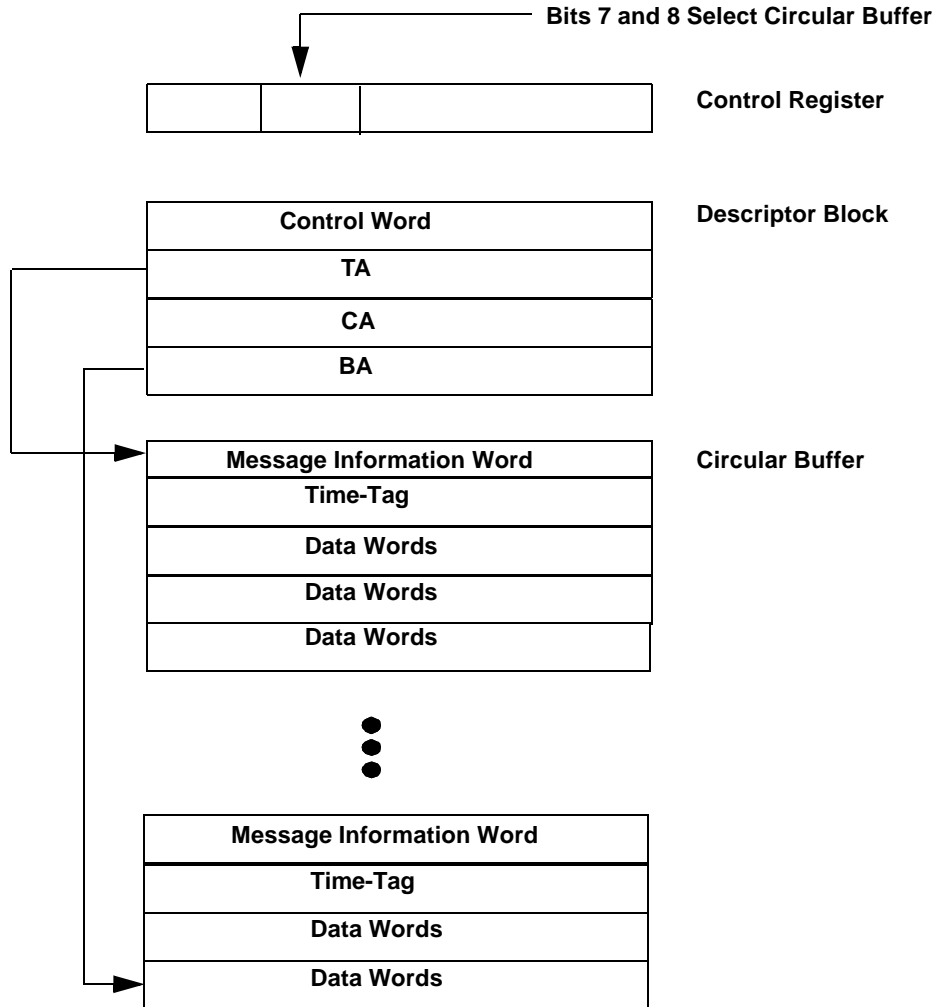

Figure 16. Circular Buffer Mode #1

5.6 Circular Buffer Mode #2

To implement Circular Buffer 2's architecture, the descriptor block and Control Register are different than in mode #0. Bits 15 through 8 of the Control Word specify the Message Information Buffer (MIB) length; the maximum MIB length is 256. Table 8 shows how the Control Word's most significant bits select the depth of the MIB. The Control Words eight most significant bits remain static during message processing.

The second word of the descriptor block defines the top address (TA_{16}) of the data circular buffer. The TA_{16} pointer remains static during message processing. The third descriptor word identifies the current address (i.e., CA_{16}) of the data circular buffer. The application software reads the dynamic CA_{16} pointer to determine the current address of the data buffer. The μ MMIT increments the CA_{16} pointer, at the end of message processing, until the MIB buffer is full. When the MIB wraps around, the μ MMIT loads the CA_{16} pointer with the TA_{16} pointer.

The fourth word in the descriptor block defines the top or base address of the Message Information Buffer (i.e., MIB) and the current MIB address (i.e., offset from base address). The μ MMIT enters the message information word and time-tag word into the MIB, for each message, until the end of the MIB is reached. When the MIB reaches the end, the next message's message information word and time-tag word is entered at the top of the MIB. The MIB pointer is a semi-static pointer. The μ MMIT updates the current address field at the end of message processing. The base address field remains static.

Application software reads the current MIB address to determine the number of messages processed since last service. The variable length MIB requires the base address and current address field to also vary in length. Table 8 displays the relationship between Control Word bits 15 through 8, MIB length, MIB base and current address fields. The current address field of the MIB must begin on an even boundary.

First is a review of receive message processing. The μ MMIT begins all message processing by reading the descriptor block of the subaddress or mode code command received (i.e., ControlWord, TA_{16} , CA_{16} , and MIB). The μ MMIT begins storage of data word(s) starting at the location contained in the CA_{16} pointer.

The μ MMIT automatically updates the CA_{16} pointer internally as message processing progresses. After receiving the correct number of data words, the μ MMIT stores the message information word and time-tag word into the MIB. At the end of message processing, the μ MMIT updates CA_{16} and MIB Current Address Field (CAF). If CAF equals the specified MIB length, CA_{16} is updated to TA_{16} and the MIB CAF is reset to zero. If CAF is less than the specified MIB length, CA_{16} and MIB CAF point to the next available memory location in each buffer. Control Word bits 15 to 8 specify the MIB length.

For transmit commands, the μ MMIT begins transmission of data from memory location CA_{16} . After message processing completes, the μ MMIT enters the message information word and time-tag word into the MIB. At the end of message processing, the μ MMIT updates CA_{16} and the MIB CAF. If CAF equals the specified MIB length, CA_{16} is updated to TA_{16} and the MIB CAF is reset to zero. If CAF is less than the specified MIB length, CA_{16} and MIB CAF point to the next available memory location in each buffer.

In this mode of operation, bits INDX, NII and A/B of the descriptor control word and the PPEN bit of the Command Register are don't care. The BRD bit is added to the Message Information Word bit 5.

The μ MMIT generates a circular buffer empty/full interrupt when the MIB reaches the end and begins a new message at the top of the buffer. Bit 8 of the Mask Register and bit 7 of the descriptor Control Word mask and enable the generation of the Full/Empty interrupt. On the occurrence of either interrupt, the MSG_INT output asserts. Figure 17 describes the relationship between TA_{16} , CA_{16} , and MIB.

Table 8. Control Word and MIB Length

| Control Word Bits (15:8) | Length of MIB | MIB Pointer Base and CAF [Base Address][CAF] = Memory Location Bit Positions |
|--------------------------|---------------|--|
| | | 15 - 14 - 13 - 12 - 11 - 10 - 9 - 8 - 7 - 6 - 5 - 4 - 3 - 2 - 1 - 0 |
| FF | 128 | [-----Base Address-----][-----CAF-----] |
| 7F | 64 | [-----Base Address-----][-----CAF-----] |
| 3F | 32 | [-----Base Address-----][-----CAF-----] |
| 1F | 16 | [-----Base Address-----][-----CAF-----] |
| 0F | 8 | [-----Base Address-----][-----CAF-----] |
| 07 | 4 | [-----Base Address-----][-----CAF-----] |
| 03 | 2 | [-----Base Address-----][-----CAF-----] |
| 01 | 1 | [-----Base Address-----][CAF] |

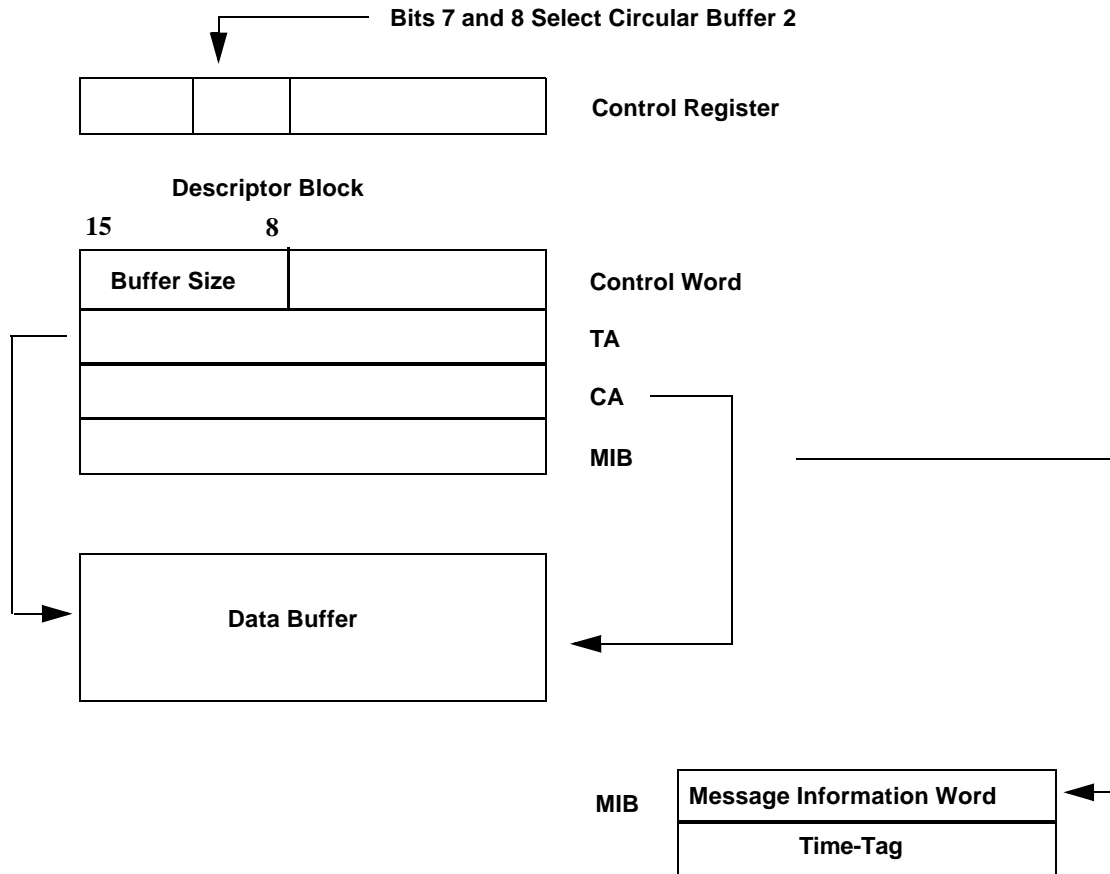

Figure 17. Circular Buffer Mode #2

5.7 Ping-Pong Enable/Disable Handshake

Prior to starting remote terminal operation, enable the buffer ping-pong feature by writing a logical 1 to bit 2 of the Control Register. During ping-pong operation, the remote terminal ping-pongs between the two data buffers, for each subaddress or mode code, on a message by message basis. Each unique MIL-STD-1553 subaddress and mode code is assigned two data buffer locations (A and B). The remote terminal retrieves data from a buffer or stores data into a buffer depending on the message type (i.e., transmit or receive command). During ping-pong operation, the remote terminal determines the active subaddress or mode code buffer at the beginning of message processing, the remote terminal complements bit 2 of the Descriptor Control Word to access the alternate buffer on the following message (i.e., ping-pong). See Figure 18 for ping-pong buffer flow chart.

To off-load or load the subaddress and mode code buffers without collisions (e.g., remote terminal writing and application software reading the same buffer), the application software must disable ping-pong operation (i.e., freeze the remote terminal access to a single buffer, either A or B). Disabling ping-pong operation allows the application software to off-load or load the alternate buffer while the remote terminal continues to use the active buffer. To implement this architecture, ping-pong operation must enable and disable asynchronously via software with feedback to indicate that buffer ping-ponging is truly disabled. Second, unique subaddress and mode code flags indicate which buffer is active. Each unique subaddress and mode code is assigned a flag which indicates the active buffer.

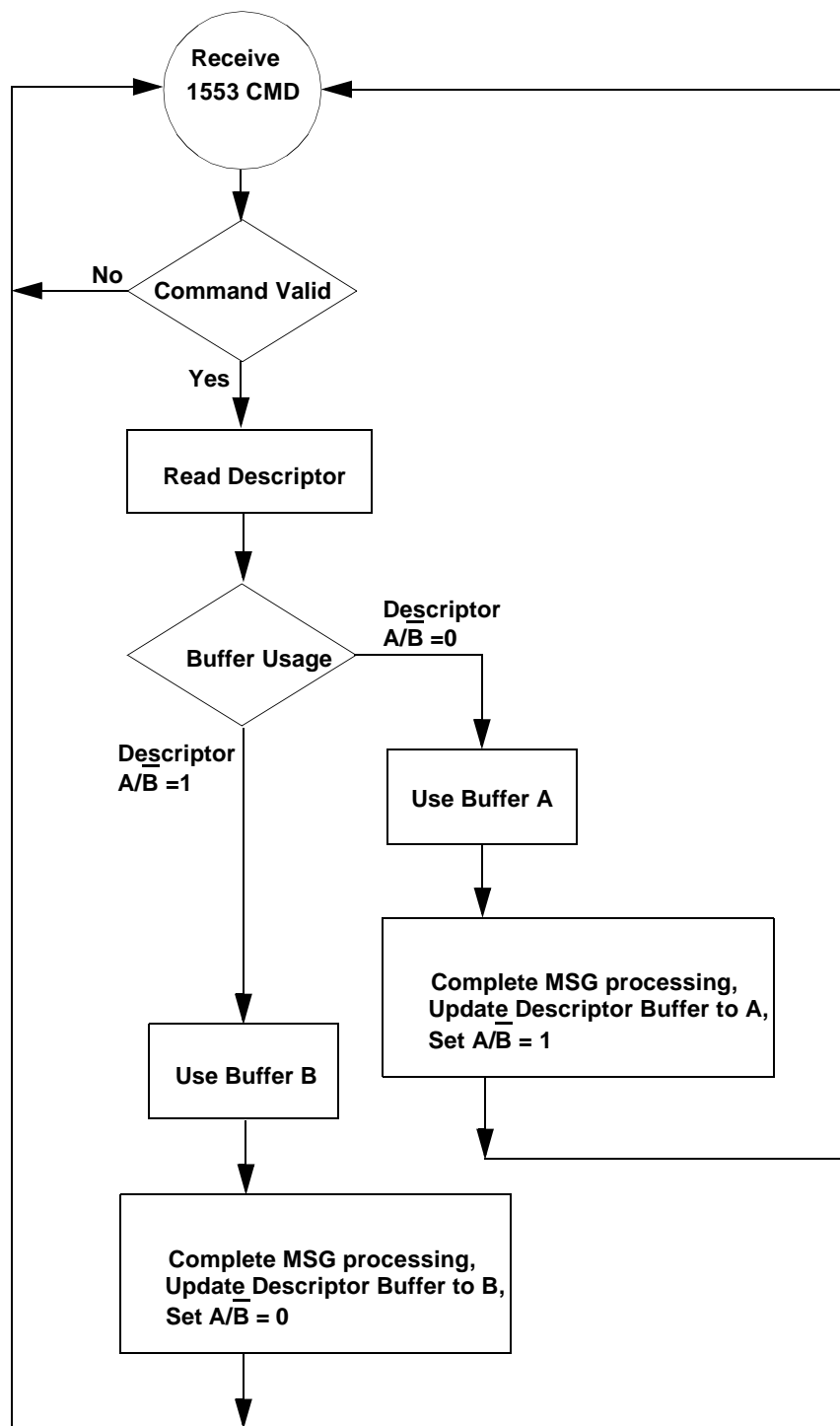

Figure 18. Ping-Pong Buffer Flow Chart

To begin the process of off-loading or loading the remote terminal's subaddress and/or mode code buffers, when using the ping-pong feature, the application software performs the following sequence: disables ping-pong operation, determines the active buffer, services the alternate buffer, enables ping-pong operation.

The application software disables ping-pong operation by writing a logical zero to Control Register bit 2. The disable of ping-pong operation is acknowledged by bit 9 of the Control Register. Bit 9 of the Control Register acknowledges the ping-pong disable by transitioning from a logical one to a logical zero. The application software interrogates bit 2 of each Descriptor Control Word to determine the active buffer on a subaddress or mode code basis. If bit 2 is a logical zero, the remote terminal uses Buffer A and the application software off-loads or loads Buffer B. If bit 2 is a logical one, the remote terminal uses Buffer B and the application software off-loads or loads Buffer A. Figure 19 displays Control Register bits for ping-pong enable/disable and acknowledge.

The application software enables ping-pong operation by writing a logical one to Control Register bit 2. The enable of ping-pong operation is acknowledged by bit 9 of the Control Register. Bit 9 of the Control Register acknowledges the ping-pong enable by transitioning from a logical zero to a logical one.

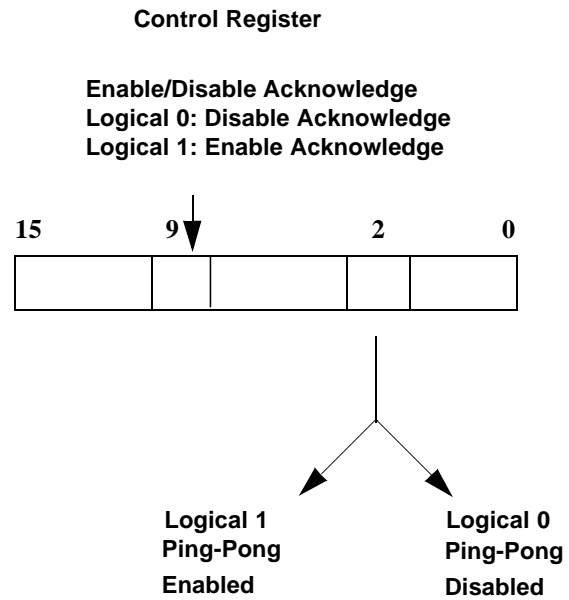

Figure 19. Ping-Pong Handshake

6.0 INTERRUPT ARCHITECTURE

6.1 SμMMIT E & SμMMIT LXE/DXE

The SμMMIT E & SμMMIT LXE/DXE interrupt architecture involves three internal registers, an Interrupt Log List and two interrupt outputs. The three internal registers include a Pending Interrupt Register, Interrupt Mask Register, and Interrupt Log List Register. See figure 20 and register descriptions for additional information. The Pending Interrupt Register contains information that identifies the events generating the interrupts. The Interrupt Mask Register allows the user to mask or disable the generation of interrupts. The Interrupt Log List Register contains the base address of a 32-word interrupt ring buffer. Two interrupt outputs signal the occurrence of an interrupt event. The interrupt architecture differentiates interrupts as either a hardware interrupt ($\overline{YF_INT}$) or message interrupt ($\overline{MSG_INT}$).

The $\overline{YF_INT}$ interrupt bits are stored in the upper four bits of the Pending Interrupt Register and the BIT Word register. These four interrupts must be processed as they occur since they are not stored in the Interrupt Log List.

Note: If the pending interrupt register is not cleared after the first $\overline{YF_INT}$, the setting of other $\overline{YF_INT}$ bits will not result in a $\overline{YF_INT}$ pulse.

The $\overline{MSG_INT}$ bits are stored in the Pending Interrupt Register. These interrupts are entered into the Interrupt Log List, if the Interrupt Log List is enabled.

The SμMMIT E & SμMMIT LXE/DXE interrupt architecture also allows the entry of 16 interrupts into a 32-word ring buffer. The SμMMIT E & SμMMIT LXE/DXE automatically handles the interrupt logging overhead. Each interrupt generates two words of information to assist the host or subsystem when processing interrupts. The Interrupt Identification Word (IIW) identifies the type(s) of interrupt that occurred. The Interrupt Address Word (IAW) identifies the interrupt source via a 16-bit address.

The SμMMIT E & SμMMIT LXE/DXE asserts one of two outputs, $\overline{MSG_INT}$ or $\overline{YF_INT}$, to signal the host or subsystem that an interrupt event occurred. The $\overline{YF_INT}$ may occur at any

time. The $\overline{MSG_INT}$ asserts after the final \overline{DMACK} negation associated with the storage of the IIW and IAW.

6.1.1 Interrupt Identification Word (IIW)

The Interrupt Identification Word (IIW) is a 16-bit word identifying the interrupt type(s). The format is similar to the Pending Interrupt Register. The host or subsystem reads the IIW to determine which interrupt event occurred. The bit description for the IIW is provided in Table 9.

6.1.2 Interrupt Address Word (IAW)

The Interrupt Address Word (IAW) is a 16-bit word that identifies the interrupt source. Depending on the mode of operation (i.e., SRT, SBC, or SMT), the IAW has different meanings. In the SRT mode of operation, the IAW identifies the subaddress or mode code descriptor that generated the interrupt. For the SBC mode of operation, the IAW points to the command block addressed when the interrupt occurred. In the SMT mode of operation, the IAW marks the monitor counter count when the interrupt occurred. The host uses the IAW with the Initial Monitor Command Block Pointer Register to determine the monitor command block that generates the interrupt.

When the SMT is operating concurrently with the SRT, the host must determine if the IAW contains information for the SRT or SMT. The determination is made by comparing the contents of the IAW base address with the descriptor base address. If a match occurs, then the IAW contains a subaddress or mode code identifier. If no match occurs, the IAW contains monitor counter information.

6.1.3 Interrupt Log List Address

The interrupt log list resides in a 32-word ring buffer. The host or subsystem defines the location buffer, within a 64K x 16 memory space, via the Interrupt Log List Register (Register 5). Restrict the ring buffer address to a 32-word boundary.

During initialization the host or subsystem writes a value to the Interrupt Log List Pointer Register, initializing the least significant five bits to a logic zero. The most significant 11 bits determine the base address of the buffer. The SμMMIT & SμMMIT LXE/DXE increments the ring buffer pointer on the

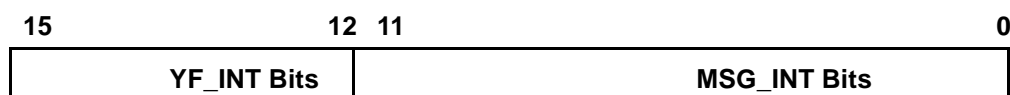

Figure 20. Pending Interrupt and Mask Register

occurrence of the first interrupt, storing the IIW and IAW at locations 00000 and 00001 respectively. The SμMMIT E & SμMMIT LXE/DXE logs ensuing interrupts sequentially into the ring buffer until interrupt number 16 occurs. The SμMMIT E & SμMMIT LXE/DXE enters interrupt 16's IIW in buffer location 11110 and the IAW at location 11111. The ring wraps-around at a value of 11111.

The SμMMIT E & SμMMIT LXE/DXE increments the ring buffer pointer as interrupts occur. The least significant five bits of the Interrupt Log List Pointer Register reflect the ring buffer pointer value. Figure 21 shows the ring buffer architecture.

The host or subsystem reads the ring buffer pointer value to determine the number of interrupts that have occurred. By extracting the least significant five bits from the Interrupt Log List Register and logically shifting the data once to the right, the host or subsystem determines the number of interrupt events.

Table 9. Interrupt Information Word

| Bit Number | Mnemonic | Description |
|-------------------|-----------------|---|
| 15-12 | N/A | Not Applicable. |
| 11 | MERR | Message Error Interrupt (All modes). |
| 10 | SUBAD | Subaddress Accessed Interrupt (SRT). |
| 9 | BDRCV | Broadcast Command Received Interrupt (SRT). |
| 8 | IXEQ0 | Index Equal Zero Interrupt (SRT). |
| 7 | ILCMD | Illegal Command Interrupt (SRT). |
| 6 | N/A | Not Applicable. |
| 5 | EOL | End of List (SBC). |
| 4 | ILLCMD | Illogical Command (SBC). |
| 3 | ILLOP | Illogical Opcode (SBC). |
| 2 | RTF | Retry Fail (SBC). |
| 1 | CBA | Command Block Accessed (SBC). |
| 0 | MBC | Monitor Block Count Equal Zero (SMT). |

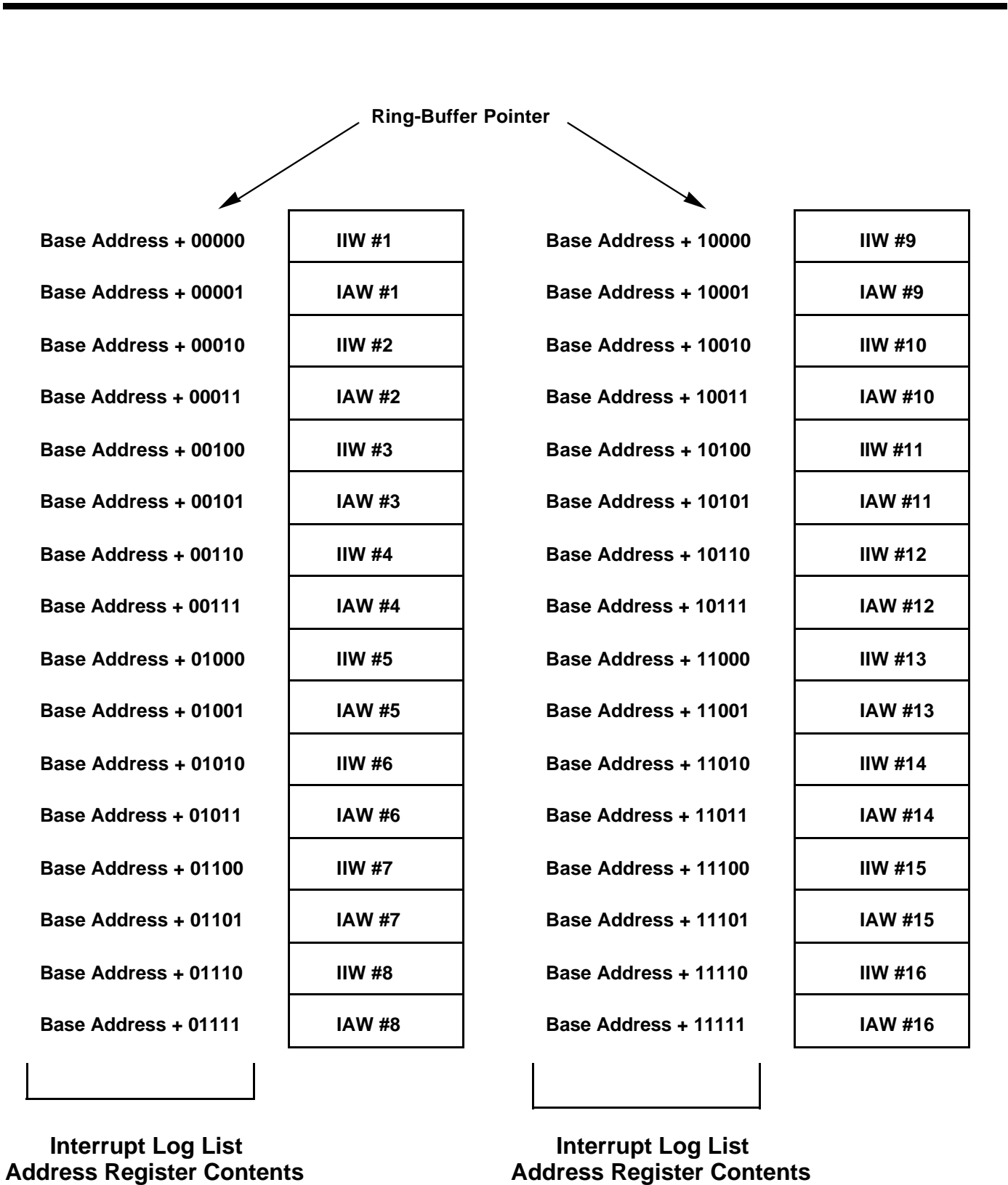

Figure 21. Interrupt Ring Buffer

6.2 SμMMIT XTE

The SμMMIT XTE's interrupt architecture involves three internal registers, an Interrupt Log List, two interrupt outputs, and two interrupt acknowledges. The three internal registers include a Pending Interrupt Register, Interrupt Mask Register, and Interrupt Log List Register. See figure 20 and register descriptions for additional information. The Pending Interrupt Register contains information that identifies the events generating the interrupts. The Interrupt Mask Register allows the user to mask or disable the generation of interrupts. The Interrupt Log List Register contains the base address of a 32-word interrupt ring buffer. Two interrupt outputs signal the occurrence of an interrupt event. The interrupt architecture differentiates interrupts as either a hardware interrupt ($\overline{YF_INT}$) or message interrupt ($\overline{MSG_INT}$). The user programs the interrupt outputs as either pulsed outputs or level outputs depending on system requirements.

Assertion of the $\overline{YF_INT}$ interrupt signals a hardware failure condition. Failures include DMA time-out, wrap-around self-test, terminal address parity, or built-in test (BIT). $\overline{YF_INT}$ failures are reflected in the four most significant bits of the Pending Interrupt Register. The $\overline{YF_INT}$ output asserts on the occurrence of a failure.

Assertion of the $\overline{MSG_INT}$ interrupt signals a message related event has occurred. $\overline{MSG_INT}$ events are reflected in the 12 least significant bits of the Pending Interrupt Register. The $\overline{MSG_INT}$ asserts after message processing is complete.

The interrupt architecture allows for the entry of 16 interrupts into a 32-word ring buffer (see figure 21). The SμMMIT XTE automatically handles the interrupt logging overhead. Each interrupt generates two words of information to help the host or subsystem perform interrupt processing. The Interrupt Identification Word (IIW) identifies the type(s) of interrupt that occurred. The Interrupt Address Word (IAW) identifies the interrupt source (e.g., subaddress or command block) via a 16-bit address.

The SμMMIT XTE's interrupt outputs are user programmable. The user can select either pulsed interrupt outputs or level sensitive outputs. In the level mode of operation, assertion of either input (i.e., $\overline{YF_ACK}$ or $\overline{MSG_ACK}$) negates the respective interrupt output (i.e., $\overline{YF_INT}$ or $\overline{MSG_INT}$). The state of MSEL(4) selects the mode of operation, Table 10 reviews operation.

Table 10. MSEL(4) Operation

| MSEL(4) | $\overline{YF_INT}$ | $\overline{YF_ACK}$ |
|---------|-----------------------|-----------------------|
| | $\overline{MSG_INT}$ | $\overline{MSG_ACK}$ |
| 0 | Pulse Output | Tied High |
| 1 | Level Output | Active Low |

6.2.1 Interrupt Identification Word (IIW)

The Interrupt Identification Word (IIW) is a 16-bit word identifying the interrupt type(s). The format is similar to the Pending Interrupt Register. The host or subsystem reads the IIW to determine which interrupt event occurred. The bit descriptor for the IIW is provided in Table 9.

6.2.2 Interrupt Address Word (IAW)

The Interrupt Address Word (IAW) is a 16-bit word that identifies the interrupt source. Depending on the mode of operation (i.e., SRT, SBC, or SMT), the IAW has different meanings. In the SRT mode of operation, the IAW identifies the subaddress or mode code descriptor that generated the interrupt. For the SBC mode of operation, the IAW points to the command block addressed when the interrupt occurred. In the SMT mode of operation, the IAW marks the monitor counter count when the interrupt occurred. The host uses the IAW with the Initial Monitor Command Block Pointer Register to determine the monitor command block that generates the interrupt.

When the SMT is operating concurrently with the SRT, the host must determine if the IAW contains information for the SRT or SMT. The determination is made by comparing the contents of the IAW base address with the descriptor base address. If a match occurs, then the IAW contains a subaddress or mode code identifier. If no match occurs, the IAW contains monitor counter information.

6.2.3 Interrupt Log List Address

The interrupt log list resides in a 32-word ring buffer. The host or subsystem defines the location buffer, within a 32K x 16 memory space, via the Interrupt Log List Register (Register 5). Restrict the ring buffer address to a 32-word boundary.

During initialization the host or subsystem writes a value to the Interrupt Log List Pointer Register, initializing the least significant five bits to a logic zero. The most significant 11 bits determines the base address of the buffer. The SμMMIT XTE increments the ring buffer pointer on the occurrence of the first interrupt, storing the IIW and IAW at locations 00000 and 00001 respectively. The SμMMIT XTE logs ensuing interrupts sequentially into the ring buffer until interrupt number 16 occurs. The SμMMIT XTE enters interrupt 16's IIW in buffer location 11110 and the IAW at location 11111. The ring wraps-around at a value of 11111.

The SμMMIT XTE increments the ring buffer pointer as interrupts occur. The least significant five bits of the Interrupt Log List Pointer Register reflect the ring buffer pointer value. Figure 21 shows the ring buffer architecture.

The host or subsystem reads the ring buffer pointer value to determine the number of interrupts that have occurred. By extracting the least significant five bits from the Interrupt Log List Register and logically shifting the data once to the right, the host or subsystem determines the number of interrupt events.

7.0 AUTO-INITIALIZATION

7.1 S μ MMIT E & S μ MMIT LXE/DXE

The S μ MMIT E & S μ MMIT LXE/DXE auto-initialization feature allows autonomous operation. The S μ MMIT E & S μ MMIT LXE/DXE will automatically configure itself for operation from nonvolatile 16-bit wide memory (PROM, ROM, E²PROM, EPROM, etc.). The configuration sequence begins after the negation of input pin $\overline{\text{MRST}}$, if $\overline{\text{AUTOEN}}$ is enabled. For each mode of operation, the auto-initialization function is different. The following section outlines the auto-initialization feature for each mode of operation.

7.1.1 SRT Auto-Initialization

During auto-initialization, the S μ MMIT E & S μ MMIT LXE/DXE loads all internal registers and transfers the descriptor space into RAM. Initialize registers not used during SRT operation to 0000 (hex). The SRT must have 32 memory locations allocated for register data.

Following register initialization, the S μ MMIT E & S μ MMIT LXE/DXE reads the descriptor from ROM and enters the descriptor into RAM. The starting address for the descriptor is read from the Descriptor Pointer Register. The S μ MMIT E & S μ MMIT LXE/DXE internally generates all address information required for auto-initialization.

The S μ MMIT E & S μ MMIT LXE /DXE requires 544 consecutive ROM locations for initialization. The 544 memory locations include: 32 for internal register information, 256 for subaddress descriptor information, and 256 for mode code descriptor information. Unused descriptor blocks should be initialized to four words of 0000 (hex).

The SRT accesses 544 consecutive memory locations in 32-word blocks. The SRT arbitrates for the bus once. Once access is granted, the SRT reads 32 words from ROM, then transfers the information into RAM. The SRT does not release the bus until all 544 ROM locations are transferred. The SRT does not respond to MIL-STD-1553 commands until initialization is complete, the start execution bit has been set, and the RT parity has been verified. After initialization, the SRT can respond to MIL-STD-1553 commands.

7.1.2 SMT Auto-Initialization

SMT auto-initialization requires only the loading of internal registers. Registers not used during SMT operation should be initialized to 0000 (hex). The SMT requires allocation of 32 memory locations for register data. The S μ MMIT E & S μ MMIT

LXE/DXE internally generates all address information for auto-initialization.

When operating as a concurrent SRT and SMT, the S μ MMIT E & S μ MMIT LXE/DXE loads all internal registers for both SRT and SMT modes of operation. The device then transfers the descriptor from ROM to RAM.

7.1.3 SBC Auto-Initialization

During auto-initialization the S μ MMIT E & S μ MMIT LXE/DXE loads all internal registers and transfers the command block(s) into RAM. Registers not used during SBC operation should be initialized to 0000 (hex). The SBC requires the allocation of 32 memory locations for register data.

Following register initialization, the S μ MMIT E & S μ MMIT LXE/DXE reads command block(s) information from ROM and enters them into RAM. The starting address for the command block(s) is read from the Command Block Pointer Register. The S μ MMIT E & S μ MMIT LXE/DXE internally generates all address information for auto-initialization.

The SBC continues to read command blocks from ROM until the Command Block Initialization Count Register decrements to zero.

7.1.4 Auto-Initialization Hardware

To enable the auto-initialization function, assert the $\overline{\text{AUTOEN}}$ pin before the rising edge of $\overline{\text{MRST}}$. The de-assertion of $\overline{\text{MRST}}$ signals the beginning of the auto-initialization sequence. The assertion of output $\overline{\text{ROMEN}}$ enables the ROM for data access. Output $\overline{\text{ROMEN}}$ remains active until the completion of auto-initialization. Simultaneous with the assertion of $\overline{\text{ROMEN}}$, the S μ MMIT E & S μ MMIT LXE/DXE arbitrates for the bus by asserting $\overline{\text{DMAR}}$. Upon completion of auto-initialization, the S μ MMIT E & S μ MMIT LXE/DXE asserts the $\overline{\text{READY}}$ output pin. Output $\overline{\text{READY}}$ asserts after negation of $\overline{\text{DMACK}}$. At this time, the S μ MMIT E & S μ MMIT LXE/DXE is prepared for operation, if it has been started (i.e., $\text{STEX}=1$). The S μ MMIT E & S μ MMIT LXE/DXE is idle until reception of a valid command word, or begins command block processing.

The ROM's starting location is 0000 (hex), RAM and ROM are overlaid by using the $\overline{\text{ROMEN}}$ output pin as a ROM device select or output enable. Figures 22a and 22b show examples of the relative timing associated with an auto-initialization sequence.

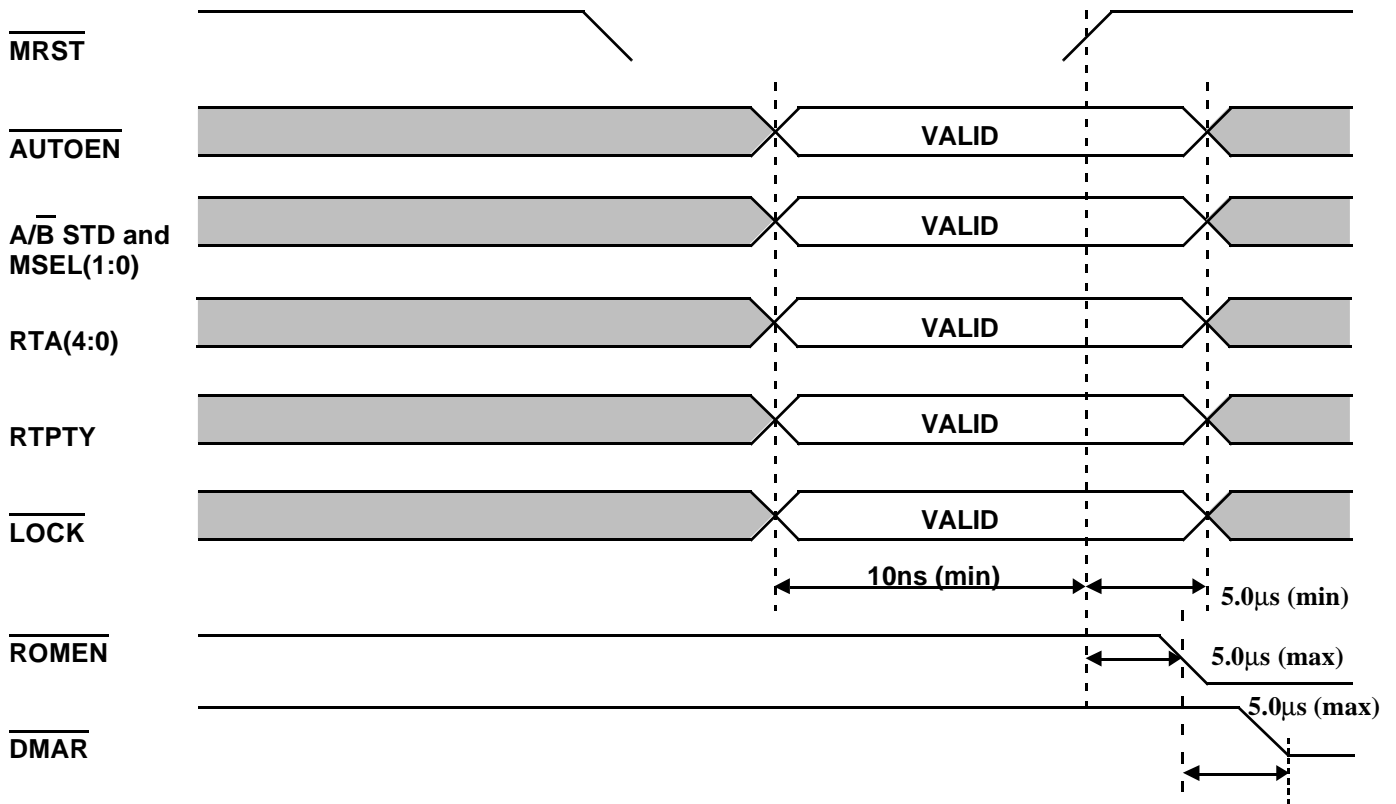

Note:

UTMC strongly recommends that these inputs remain static until the assertion of $\overline{\text{READY}}$.

Figure 22a. Auto-Initialization Timing

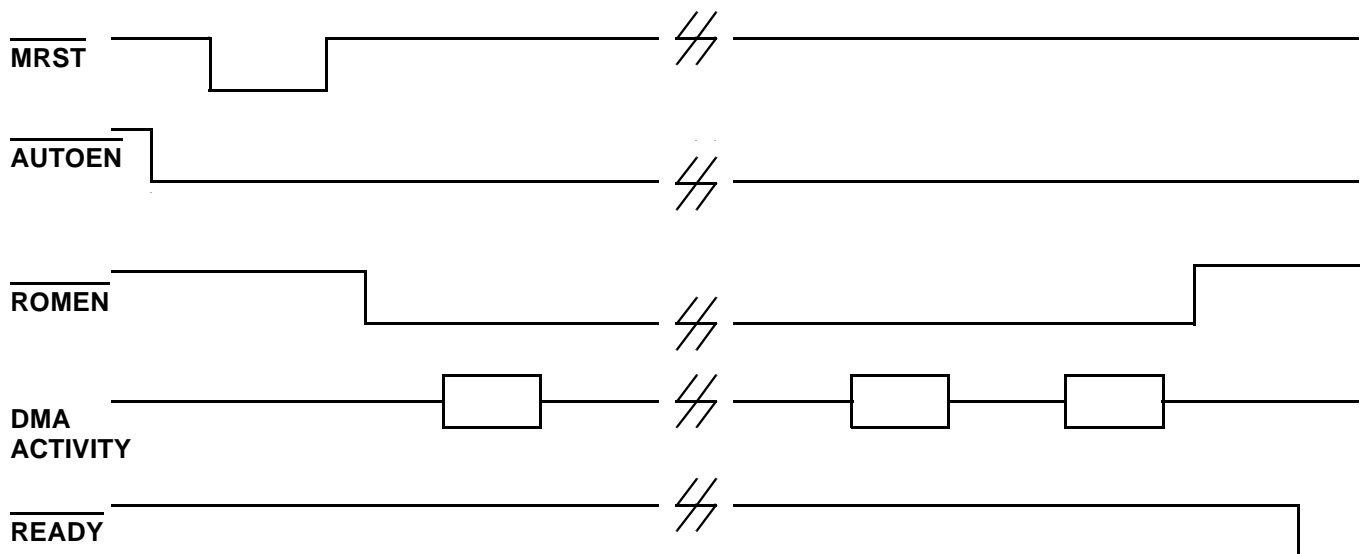

Figure 22b. Auto-Initialization DMA Sequence

7.2 SμMMIT XTE

The SμMMIT XTE auto-initialization feature allows autonomous operation. The SμMMIT XTE will automatically configure itself for operation from nonvolatile byte-wide memory (PROM, ROM, E²PROM, EPROM, etc.). The configuration sequence begins after the negation of input pin $\overline{\text{MRST}}$, if $\overline{\text{AUTOEN}}$ is enabled. For each mode of operation, the auto-initialization function is different. The following sections outline the auto-initialization feature for each mode of operation.

7.2.1 SRT Auto-Initialization

During auto-initialization, the SμMMIT XTE loads all internal registers and transfers the descriptor space into RAM. Initialize registers not used during SRT operation to 0000 (hex). The SRT must have 64 memory locations allocated for register data.

Following register initialization, the SμMMIT XTE reads the descriptor from ROM and enters the descriptor into RAM. The starting address for the descriptor is read from the Descriptor Pointer Register. The SμMMIT XTE internally generates all address information required for auto-initialization.

The SμMMIT XTE requires 1088 consecutive ROM locations for initialization. The 1088 memory locations include: 64 for internal register information, 512 for subaddress descriptor information, and 512 for mode code descriptor information. Unused descriptor blocks should be initialized to four words of 0000 (hex).

The SRT accesses 1088 consecutive memory locations in 64-word blocks. Once access is granted, the SRT reads words from ROM, then transfers the information into RAM. The SRT does not respond to MIL-STD-1553 commands until initialization is complete, the start execution bit has been set, and the RT parity has been verified. After initialization, the SRT can respond to MIL-STD-1553 commands.

7.2.2 SMT Auto-Initialization

SMT auto-initialization requires only the loading of internal registers. Registers not used during SMT operation should be initialized to 0000 (hex). The SMT requires allocation of 64 memory locations for register data. The SμMMIT XTE internally generates all address information for auto-initialization.

When operating as a concurrent SRT and SMT, the SμMMIT XTE loads all internal registers for both SRT and SMT modes of operation. The device then transfers the descriptor from ROM to RAM.

7.2.3 SBC Auto-Initialization

During auto-initialization the SμMMIT XTE loads all internal registers and transfers the command block(s) into RAM. Registers not used during SBC operation should be initialized to 0000 (hex). The SBC requires the allocation of 64 memory locations for register data.

Following register initialization, the SμMMIT XTE reads command block(s) information from ROM and enters them into RAM. The starting address for the command block(s) is read from the Command Block Pointer Register. The SμMMIT XTE internally generates all address information for auto-initialization.

The SBC continues to read command blocks from ROM until the Command Block Initialization Count Register decrements to zero.

7.2.4 Auto-Initialization Hardware

An external auto-initialization bus allows configuration of SμMMIT XTE without host intervention. Auto-initialization is ideal for low cost remote sensing applications where a host microprocessor or microcontroller is not required.

To enable the auto-initialization function, assert the $\overline{\text{AUTOEN}}$ pin prior to the rising edge of $\overline{\text{MRST}}$. The assertion of $\overline{\text{MRST}}$ signals the beginning of the auto-initialization sequence. The SμMMIT XTE enables the boot memory by asserting the $\overline{\text{ECS}}$ output. The SμMMIT XTE accesses up to 8K x 8 words via the auto-initialization bus. Table 8 reviews the memory requirements for SμMMIT XTE auto-initialization.

Table 11. Auto-Initialization Memory Requirements

| Mode | Memory (x8) |
|------|--------------------------|
| SRT | 1088 |
| SMT | 64 |
| SBC | $64 + [N \times (16)]^1$ |

Note:

1. N equals the number of command blocks.

To interface to slower non-volatile memory the auto-initialization read cycle period is programmable. The user selects between zero and seven wait states per read. A wait state is equal to 82ns. The user programs the read cycle duration via inputs EC(2:0). The S μ MMIT XTE latches inputs EC(2:0) on the rising edge of $\overline{\text{MRST}}$. Table 12 reviews the possible combinations of wait-states. Figures 23a and 23b show a system configuration along with typical auto-initialization read cycles. Following completion of an auto-initialization sequence the S μ MMIT XTE asserts the $\overline{\text{READY}}$ output.

Table 12. Programmable Wait-State

| EC(2:0) ₂ | Number of Wait-States |
|----------------------|-----------------------|
| 000 | 0 |
| 001 | 1 |
| 010 | 2 |
| 011 | 3 |
| 100 | 4 |
| 101 | 5 |
| 110 | 6 |
| 111 | 7 |

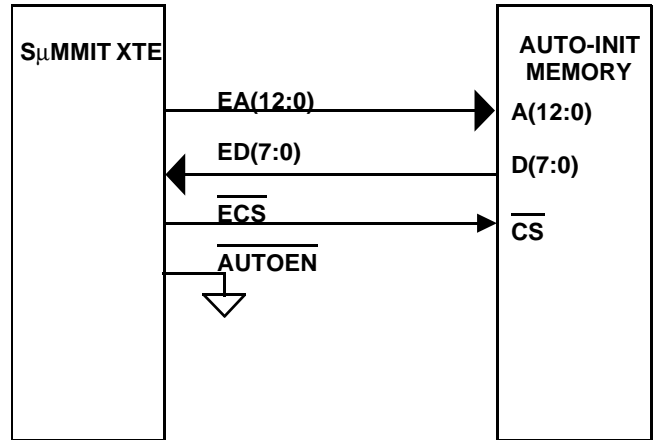
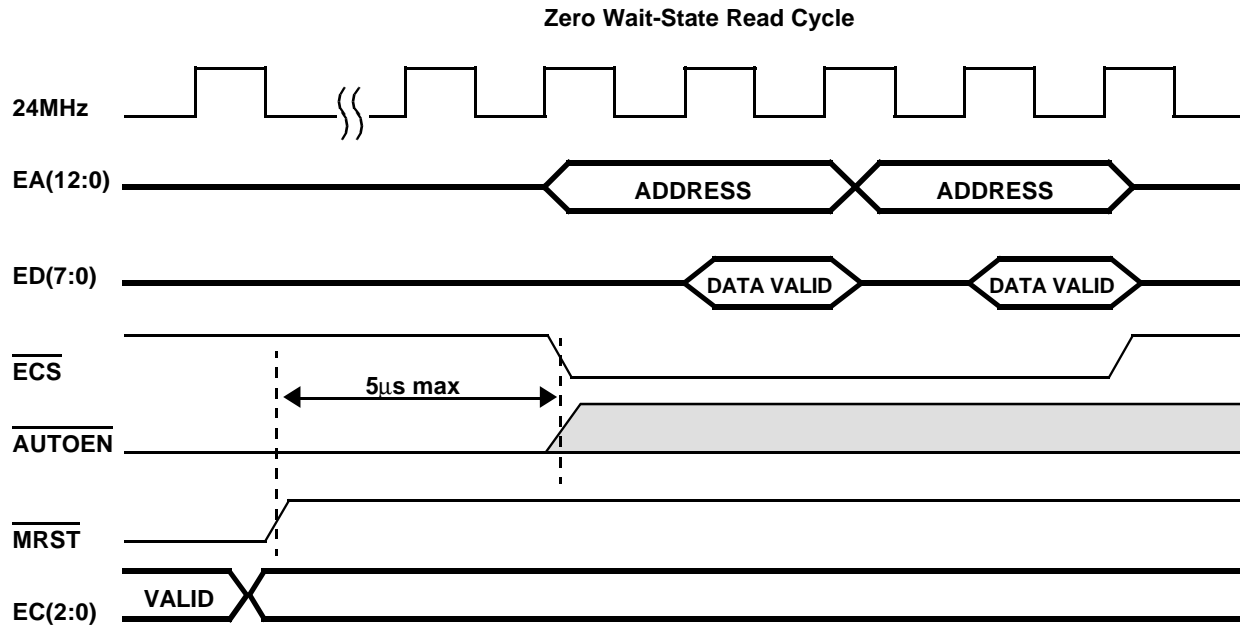

Figure 23a. Auto-Initialization System Configuration



Note:
Two bytes are read on each ECS cycle using only an address transition (AT).

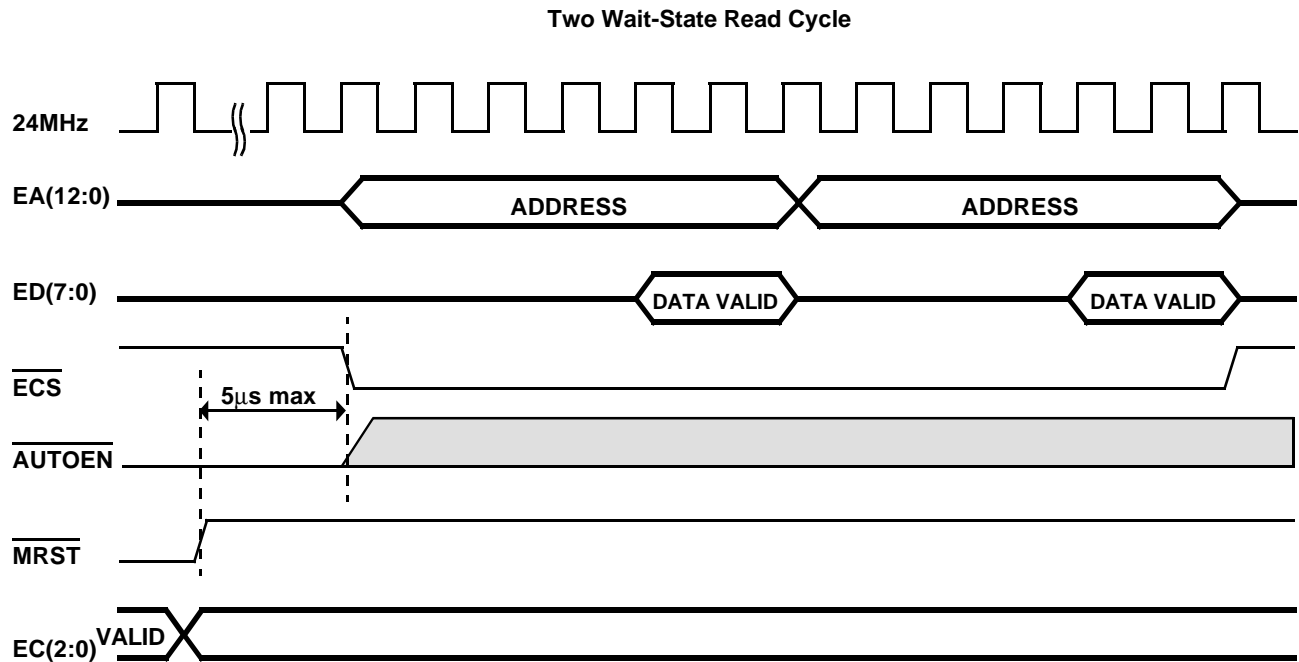

Figure 23b. Auto-Initialization Read Cycle

8.0 Testability

The following sections review the built-in test capabilities of the S μ MMIT family. The S μ MMIT family ranges from the simple S μ MMIT E to the complex S μ MMIT XTE. The varying complexity results in slightly different test techniques to exercise each product type. Table 13 is a list of the various components that comprehend each of the different S μ MMIT product.

Table 13. S μ MMIT Family Internal Component List

| Product | Protocol Die | Transceivers | Memory | MMU |
|------------------|--------------|--------------|--------|-----|
| S μ MMIT E | Yes | No | No | No |
| S μ MMIT LXE | Yes | Yes | No | No |
| S μ MMIT DXE | Yes | Yes | No | No |
| S μ MMIT XTE | Yes | Yes | Yes | Yes |

A S μ MMIT product's built-in test (BIT) varies depending on the product's internal component mix and the BIT initiating sequence. BIT's execution time will also vary depending on the number of internal components under test. Table 14 reviews the various BIT initiation sequences and the components that the sequence tests along with BIT execution times.

Table 14. BIT Initiation

| Initiation Type | Protocol Die | Transceivers ¹ | Memory | MMU | Execution Time ² |
|----------------------------------|--------------|---------------------------|--------|-----|-----------------------------|
| CPU Initiated ² | Yes | No | Yes | No | 1mS/80mS |
| Mode Code Initiated ⁴ | Yes | No | No | No | 1mS |
| Op-Code Initiated ⁵ | Yes | No | No | No | 1mS |
| JTAG 1149.1 ⁶ | Yes | No | No | Yes | N/A |
| JTAG/RUNBIST | Yes | No | No | No | 1mS |

Notes:

1. The transceiver is tested with the data wrap-around feature of the S μ MMIT family. See sections 2.1.5, 3.1.5, 4.1.5.
2. Control Register write of 4000₁₆. Before initiating memory test, reset the S μ MMIT XTE by asserting $\overline{\text{MRST}}$.
3. Remote Terminal mode of operation, BIT initiated after reception of mode code command.
4. Bus Controller mode of operation, BIT initiated after the fetch of a command block containing an initiate BIT op-code.
5. S μ MMIT test 1mS. Memory test 70mS.
6. JTAG can operate up to 1MHz.

9.0 SYSTEM CONFIGURATION

9.1 S μ MMIT E & S μ MMIT LXE/DXE

9.1.1 Transmitter/Receiver Interface

The S μ MMIT Manchester II encoder/decoder interfaces directly with the UT63M100 Series Bus Transceiver, using TA- $\overline{\text{TA}}$ and RA- $\overline{\text{RA}}$ signals for Channel A, and TB- $\overline{\text{TB}}$ and RB- $\overline{\text{RB}}$ signals for Channel B. See appendix I for additional information on UTMIC transceivers. The S μ MMIT also provides $\overline{\text{TIMERONA}}$ and $\overline{\text{TIMERONB}}$ output signals to assist in meeting the MIL-STD-1553B fail-safe timer requirements (see figures 24a and 24b). Reference section 10 for S μ MMIT LXE/DXE serial bus interface information.

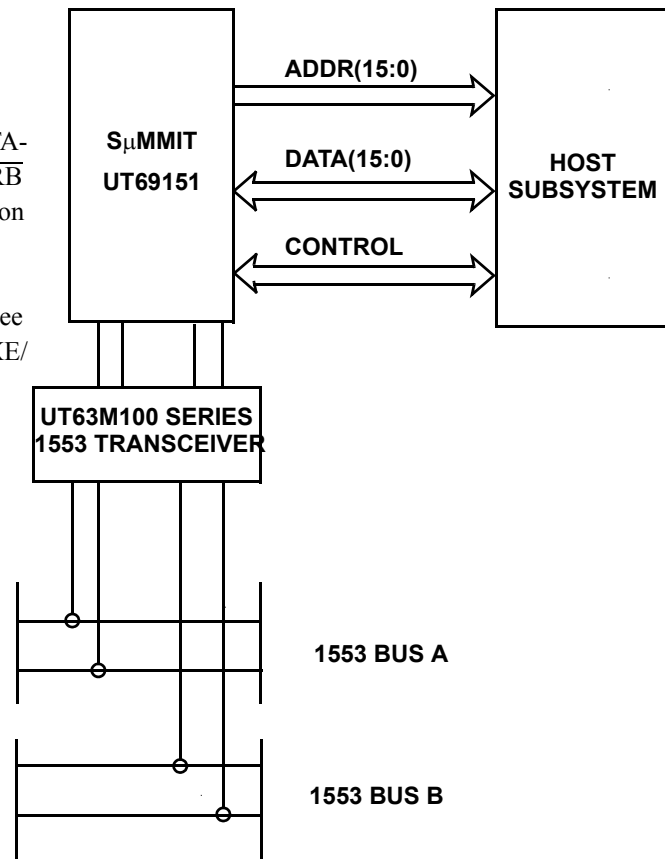

Figure 24a. S μ MMIT General System Diagram

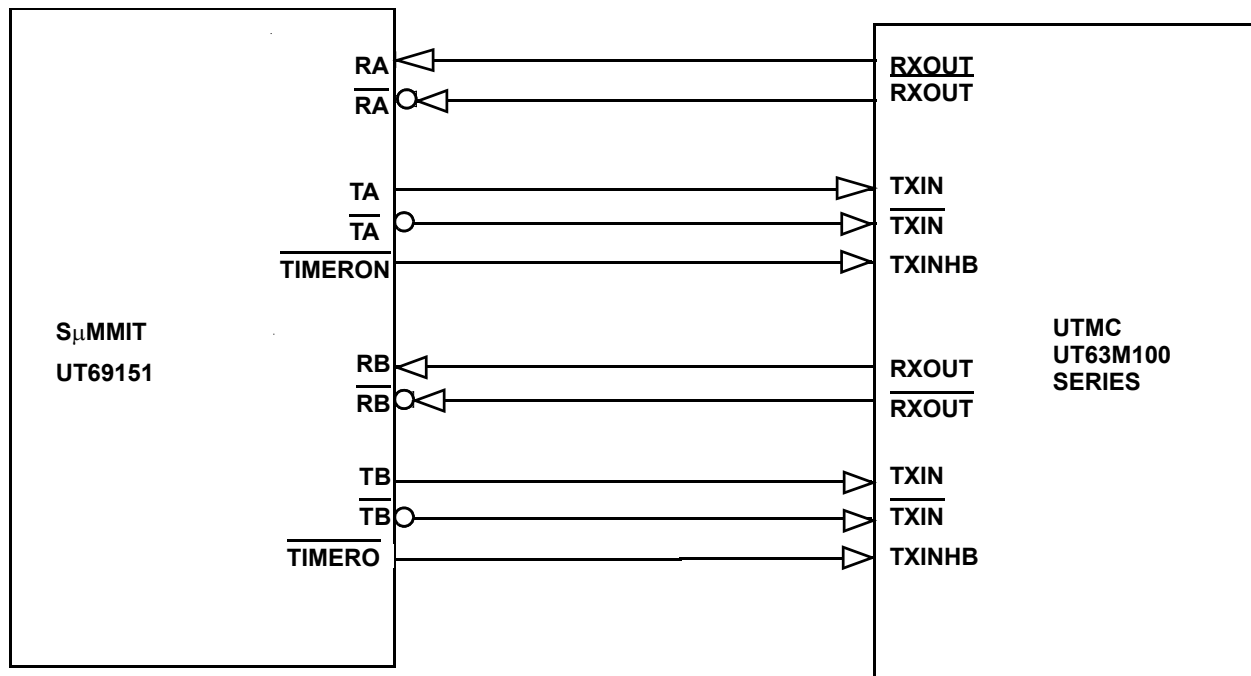

Figure 24b. S μ MMIT Transceiver Interface Diagram

9.1.2 Register Transfers

The host's or subsystem's access to the S μ MMIT E & S μ MMIT LXE/DXE internal registers is similar to its access to RAM. After gaining control of the memory bus, the host supplies address information to bidirectional address bus pins A(4:0). After supplying the address information, the host asserts S μ MMIT E & S μ MMIT LXE/DXE inputs \overline{CS} and RD/ \overline{WR} to designate a register access and the type of access. The memory access terminates on the negation of \overline{CS} . For more information on register cycles refer to the timing diagrams and AC electrical specifications in section 20. For register utilization versus mode of operation see Table 15.

Note: Modifying (i.e., writing) internal registers is not recommended while the S μ MMITE & S μ MMITLXE/DXE is processing messages (i.e., \overline{TERACT} active). The only exception occurs when the S μ MMIT E & S μ MMIT LXE/DXE is in the SBC mode of operation where a write to bit 15 of the Control Register is permitted.

Table 15. Internal Register Utilization

| Register Number | Register Number 8-Bit Mode (S μ MMIT XTE only) | Register Name | SRT | SBC | SMT |
|-----------------|--|---|-----------|-----|-----|
| 0 | 0,1 | Control | ✓ | ✓ | ✓ |
| 1 | 2,3 | Operational Status | ✓ | ✓ | ✓ |
| 2 | 4,5 | Current Command | ✓ | ✓ | ✓ |
| 3 | 6,7 | Interrupt Mask | ✓ | ✓ | ✓ |
| 4 | 8,9 | Pending Interrupt | ✓ | ✓ | ✓ |
| 5 | A,B | Interrupt Log List | ✓ | ✓ | ✓ |
| 6 | C,D | BIT Word | ✓ | ✓ | ✓ |
| 7 | E,F | Time Tag (SRT and SMT) Miner Frame Timer (SBC) | ✓ | ✓ | ✓ |
| 8 | 10,11 | SRT Descriptor Pointer (SRT) Command Block Pointer (SBC) | ✓ | ✓ | |
| 9 | 12,13 | 1553 Status Word Bits | ✓ | | |
| A | 14,15 | Command Block Initialization Count (BC) | | ✓ | |
| B | 16,17 | Initial Monitor Command Block Pointer | | | ✓ |
| C | 18,19 | Initial Monitor Data Pointer | | | ✓ |
| D | 1A,1B | Monitor Block Count | | | ✓ |
| E | 1C,1D | Monitor Filter | | | ✓ |
| F | 1E,1F | Monitor Filter | | | ✓ |
| 10 to 1F | 20 to 3F | Illegalization | ✓ (16) | | |
| | | Total | 26 | 10 | 13 |

9.1.3 DMA Configuration

For a DMA system configuration the S μ MMIT E & S μ MMIT LXE/DXE shares memory with the host and/or subsystem. The S μ MMIT E & S μ MMIT LXE/DXE gains access to memory through an arbitration process. The S μ MMIT E & S μ MMIT LXE/DXE requests access to memory by asserting the $\overline{\text{DMAR}}$ signal. After receiving a grant signal (i.e., assertion of $\overline{\text{DMAG}}$) from the bus arbiter, the S μ MMIT E & S μ MMIT LXE/DXE asserts $\overline{\text{DMACK}}$ to acknowledge control of the bus. The S μ MMIT E & S μ MMIT LXE/DXE continues to assert $\overline{\text{DMACK}}$ until all accesses are complete. After completion of all accesses, $\overline{\text{DMACK}}$ negates releasing the bus. Figure 25 shows an example DMA system configuration.

9.1.4 DMA Transfers

Following the assertion of $\overline{\text{DMACK}}$, the S μ MMIT activates the address bus A(15:0). During write cycles, the bidirectional data bus D(15:0) activates, supplying data for the write cycle. For read cycles, the bidirectional data bus remains an input. Memory control signals $\overline{\text{RCS}}$, $\overline{\text{RRD}}$, and $\overline{\text{RWR}}$ assert following the address bus activation. These signals control the memory chip select, output enable and write inputs. Table 16 is a summary of DMA activity during message processing.

For both read and write memory cycles, $\overline{\text{DTACK}}$ is an input to the S μ MMIT E & S μ MMIT LXE/DXE. A non-wait state memory access requires two clock cycles. For accessing slower memory devices, hold $\overline{\text{DTACK}}$ to a logical one. This results in the stretching of memory cycles beyond the two clock cycles. The S μ MMIT E & S μ MMIT LXE/DXE samples $\overline{\text{DTACK}}$ on the rising edge of the 24 MHz clock. If the memory logic fails to assert $\overline{\text{DTACK}}$ before the rising edge of the clock, the S μ MMIT E & S μ MMIT LXE/DXE extends the memory cycle. One clock cycle is added to the memory cycle and $\overline{\text{DTACK}}$ is again sampled on the clock rising edge. If $\overline{\text{DTACK}}$ remains negated, the S μ MMIT E & S μ MMIT LXE/DXE continues to add one clock cycle to the memory cycle and samples $\overline{\text{DTACK}}$ on each rising edge of the clock.

UTMC's UT54ACS220/UT54ACTS220 automatically generates one wait state for either the S μ MMIT E or S μ MMIT LXE/DXE. See figure 26 for additional information. See appendix 2 for additional information on the UT54ACS220/UT54ACTS220.

Assertion of $\overline{\text{DTACK}}$ signals the S μ MMIT E & S μ MMIT LXE/DXE to terminate the memory cycle. The memory cycle terminates one clock cycle after $\overline{\text{DTACK}}$ assertion. For more information on memory cycles, refer to the timing diagrams and AC electrical specifications in section 20.

9.1.5 Buffer Mode Operation

The S μ MMIT E & S μ MMIT LXE/DXE have the optional use of an internal 32-word buffer to enhance message processing. Use of this internal buffer decreases the number of times the S μ MMIT E & S μ MMIT LXE/DXE arbitrates for memory during message processing. The number of memory accesses required to process a command is dependent on the mode of operation (SRT, SBC, SMT).

The S μ MMIT E & S μ MMIT LXE/DXE stores all data words associated with a receive message into memory using a single DMA burst. When transmitting information, the S μ MMIT E & S μ MMIT LXE/DXE arbitrates for a memory access and extracts all data for transmission from external memory in a single DMA burst. For either receive or transmit messages, the S μ MMIT E & S μ MMIT LXE/DXE does not release the memory bus until all data is transferred to or from external memory. The buffer mode of operation eliminates the S μ MMIT E & S μ MMIT LXE/DXE arbitration for the bus each time a data word memory access is required.

To enable use of the internal message buffer, the host asserts bit 6 of the Control Register. If the buffer feature is not enabled, the S μ MMIT E & S μ MMIT LXE/DXE arbitrates each time data storage or retrieval is required. The host or subsystem does not have access to this internal buffer.

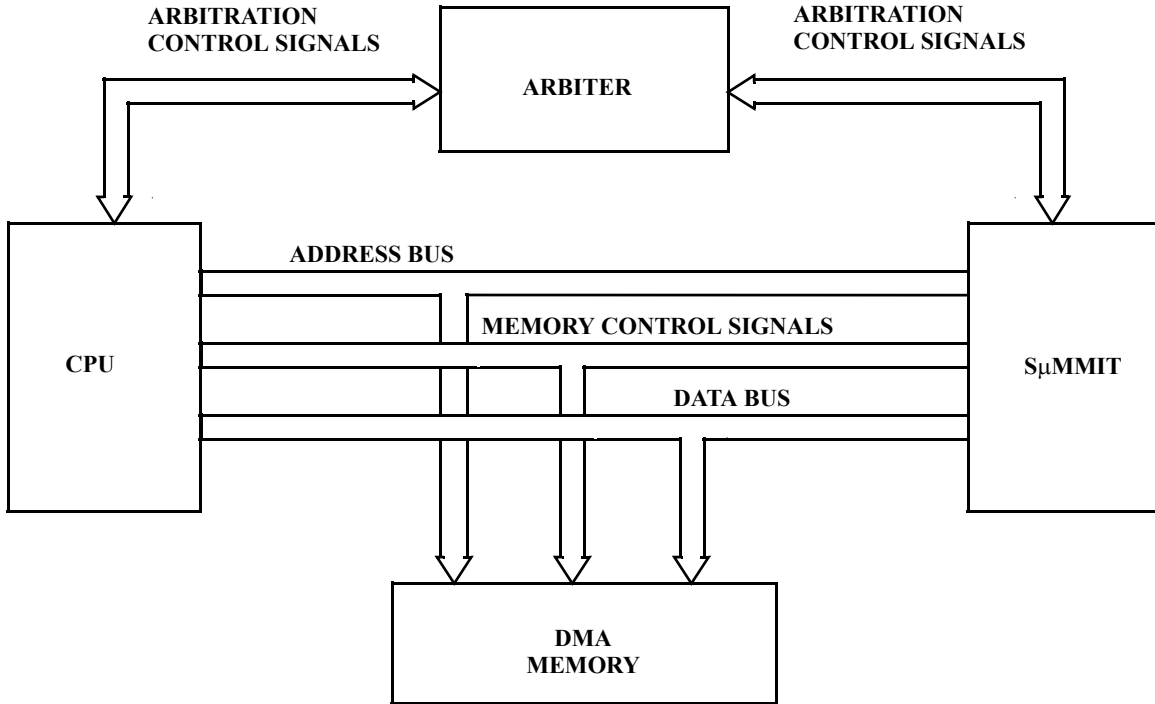

Figure 25. DMA System Configuration

Table 16. DMA

BC Write Scenario

| Number of Words | Word Type |
|-------------------|--|
| 1-32 ¹ | Data Word |
| 2 | Interrupt Information Word Interrupt Address Word |
| 6 | Control Word Cmd Word 1 Cmd Word 2 Data Pointer Status Word 1 Status Word 2 |
| 8 | Control Word Cmd Word 1 Cmd Word 2 Data Pointer Status Word 1 Status Word 2 Interrupt Information Word Interrupt Address Word |

BC Read Scenario

| Number of Words | Word Type |
|-------------------|---|
| 1-32 ¹ | Data Word |
| 8 | Control Word Cmd Word 1 Cmd Word 2 Data Pointer Status Word 1 Status Word 2 Branch Address Timer Value |

Monitor Write Scenario

| Number of Words | Word Type |
|-------------------|---|
| 1-32 ¹ | Data Word |
| 7 | Control Word Cmd Word 1 Cmd Word 2 Data Pointer Status Word 1 Status Word 2 Time Tag |
| 9 | Control Word Cmd Word 1 Cmd Word 2 Data Pointer Status Word 1 Status Word 2 Time Tag Interrupt Status Word Interrupt Address Word |

RT Write Scenario

| Number of Words | Word Type |
|-------------------|---|
| 1-32 ¹ | Data Word |
| 3 | Message Information Word Time-Tag Word Control Word |
| 4 | Message Information Word Time-Tag Word Control Word Data Pointer |
| 5 | Message Information Word Time-Tag Word Control Word Interrupt Information Word Interrupt Address Word |
| 6 | Message Information Word Time-Tag Word Control Word Data Pointer Interrupt Information Word Interrupt Address Word |

RT Read Scenario

| Number of Words | Word Type |
|-------------------|--|
| 1-32 ¹ | Data Word |
| 4 | Control Word Data Pointer A Data Pointer B Broadcast Data Pointer |

Note:

1. If buffer mode selected, more than 1 and up to 32 words can be read/written.

9.2 SμMMIT XTE

The SμMMIT XTE supplies hardware designers with a flexible interface to meet the needs of state-of-the-art MIL-STD-1553 interfaces. The SμMMIT XTE contains internal SRAM and a memory management unit, interfaces to either 8-bit or 16-bit subsystems, supports multiplexed and non-multiplexed interfaces, and has user selectable control signals.

9.2.1 Internal Registers

The SμMMIT XTE contains 32 internal registers that control and report on message activity and operation. The 32 registers are memory mapped into the subsystem memory. Table 17 reviews the registers and identifies the mode of operation applicable. The host reads or writes these registers using the timing diagrams shown in figures 27 a-d.

9.2.2 Memory Map

The SμMMIT XTE contains 512Kbits of memory for message storage and system data storage. MSEL(5) determines the organization of the memory as either by 16 or by 8. When organized by 16 (i.e., MSEL(5) = 0) the SμMMIT XTE's internal memory looks like 32K x 16 of SRAM. For by 8

applications (MSEL(5) = 1) the SμMMIT XTE's internal memory looks like 64K x 8 of SRAM. The host reads or writes SRAM using the timing diagrams shown in figures 27 a-d. Table 17 shows the memory organization for either 8-bit or 16-bit operation.

9.2.3 Buffer Mode Operation

For the SμMMIT XTE operation, disable buffer mode, i.e., control register bit 6 = Logic 0.

9.2.4 Hardware Interface

The SμMMIT XTE offers hardware designers a flexible interface to commonly found embedded computers. The hardware designer selects control signals, bus widths, and bus functionality (i.e., non-multiplexed versus multiplexed) to meet their interface requirements. Table 18 reviews how the user selects the SμMMIT XTE's operation that best meets their interface requirements.

Figures 28 a-d show typical system interfaces and use of the mode select inputs to configure the SμMMIT XTE to interface to various embedded computers.

Table 17. Memory Organization

| Mode | Memory Organization | Register Location | Memory Range |
|--------|---------------------|--------------------------|--------------------------|
| 8-bit | 64K x 8 | 0000 (hex) to 003F (hex) | 0040 (hex) to FFFF (hex) |
| 16-bit | 32K x 16 | 0000 (hex) to 001F (hex) | 0020 (hex) to 7FFF (hex) |

Table 18. User-Selectable Control Signals

| Function | Input Pin | Logic 1 | Logic 0 |
|--------------------------|-----------|---|--|
| Control Signal Select | MSEL(2) | $\overline{R/\overline{WR}}$, \overline{CS} , \overline{DS} , \overline{RDY} | \overline{RD} , \overline{WR} , \overline{CS} , \overline{RDY} , \overline{DS} |
| Bus Functionality Select | MSEL(3) | Non-Multiplexed Address and Data | Multiplexed Address and Data, ALE |
| Interrupt Select | MSEL(4) | Level ($\overline{YF_INT}$, $\overline{MSG_INT}$, $\overline{YF_ACK}$, and $\overline{MSG_ACK}$) | Pulse ($\overline{YF_INT}$ and $\overline{MSG_INT}$) |
| Bus Width Select | MSEL(5) | 8-bit | 16-bit |

Non-Multiplexed Memory Register Write Access (8-bit Mode)^{1, 2}

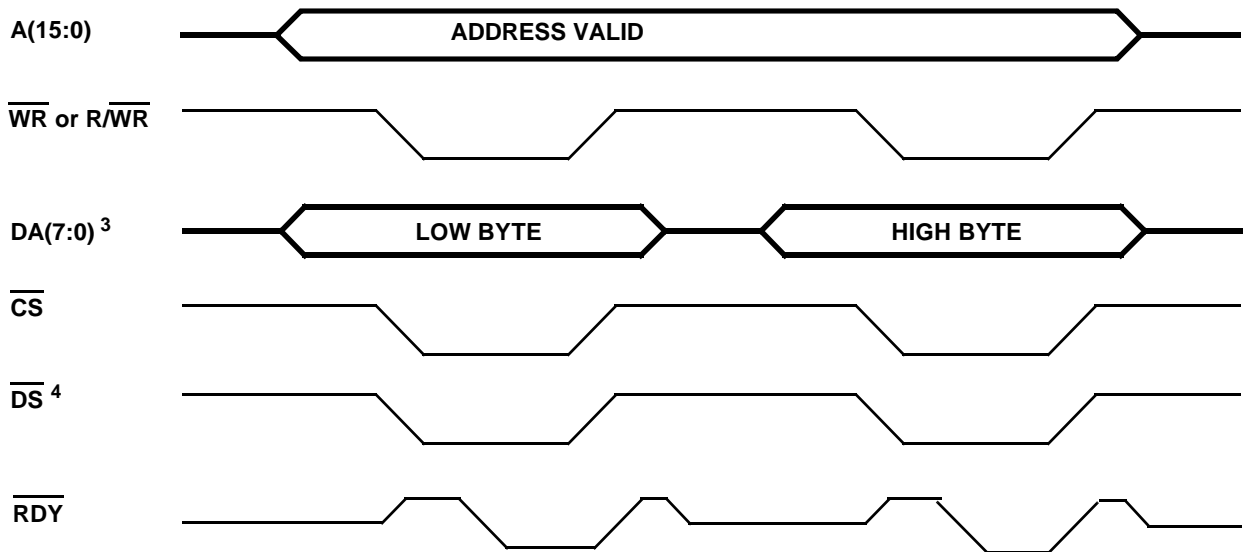

Notes:

1. ALE must be tied high.
2. Latter assertion of \overline{CS} , \overline{DS} , \overline{WR} or $\overline{R/\overline{WR}}$ starts cycle.
3. Tie DA(15:8) to V_{DD} via a 10K resistor.
4. \overline{DS} asserts to signal that data is valid on the bus.

Non-Multiplexed Memory/Register Read Access (8-bit Mode)^{1, 2}

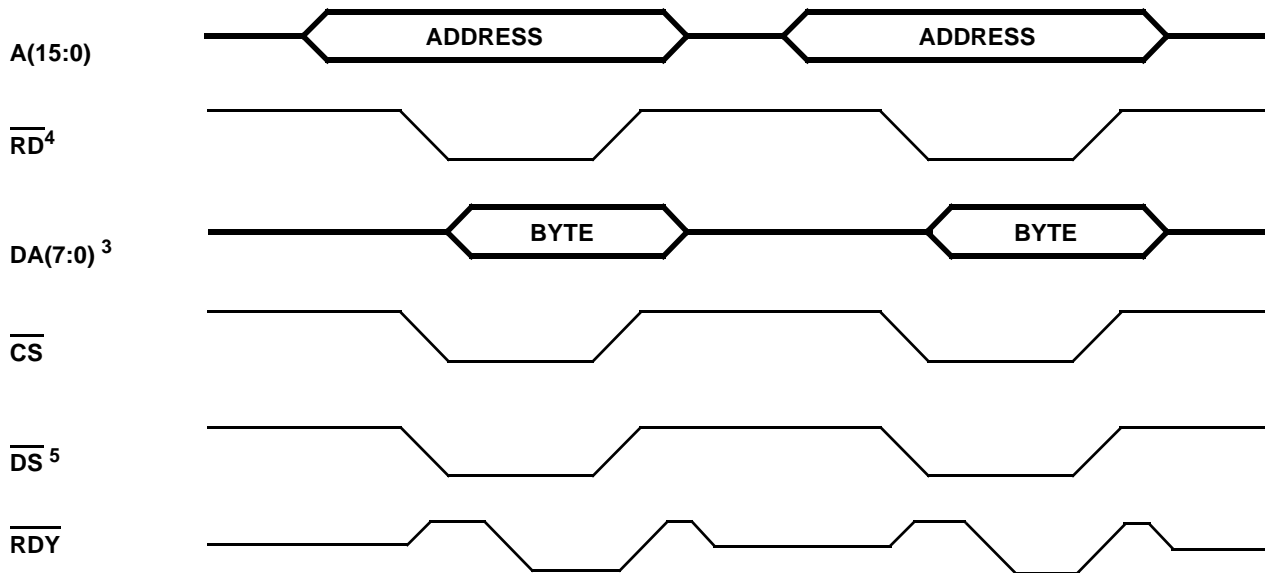

Notes:

1. ALE must be tied high.
2. Latter assertion of \overline{CS} , \overline{DS} , \overline{RD} starts cycle.
3. Tie DA(15:8) to V_{DD} via a 10K resistor.
4. When using $\overline{R/\overline{WR}}$ as an input signal tie \overline{RD} to a logical one. During the read cycle $\overline{R/\overline{WR}}$ remains a logical 1.
5. \overline{DS} asserts to signal the μ MMIT XTE to place data on the bus.

Figure 27a. 8-bit Memory and Register Access

Non-Multiplexed Memory/Register Write Access (16-bit Mode)^{1,2}

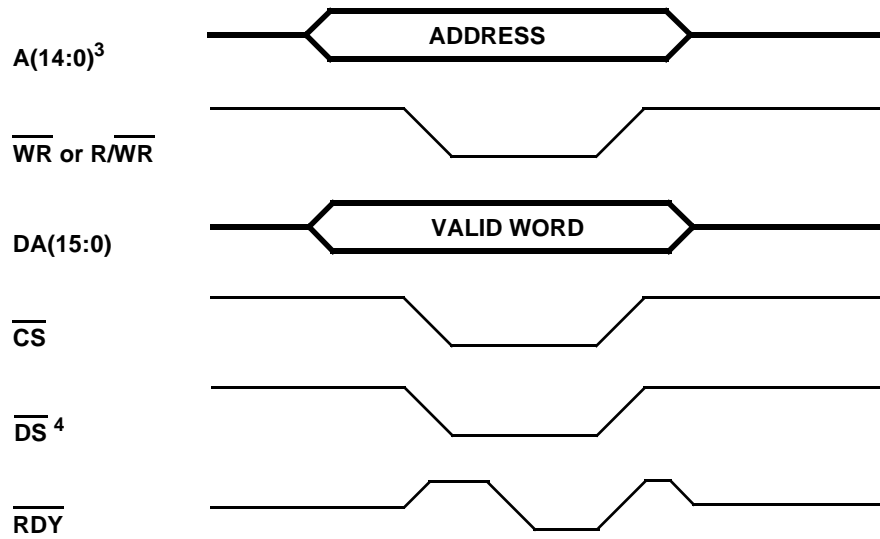

Notes:

1. ALE must be tied high.
2. Latter assertion of $\overline{\text{CS}}$, $\overline{\text{DS}}$, $\overline{\text{WR}}$ or $\overline{\text{R/WR}}$ starts cycle.
3. A15 must be tied low.
4. $\overline{\text{DS}}$ asserts to signal that data is valid on the bus.

Non-Multiplexed Memory/Register Read Access (16-bit Mode)^{1,2}

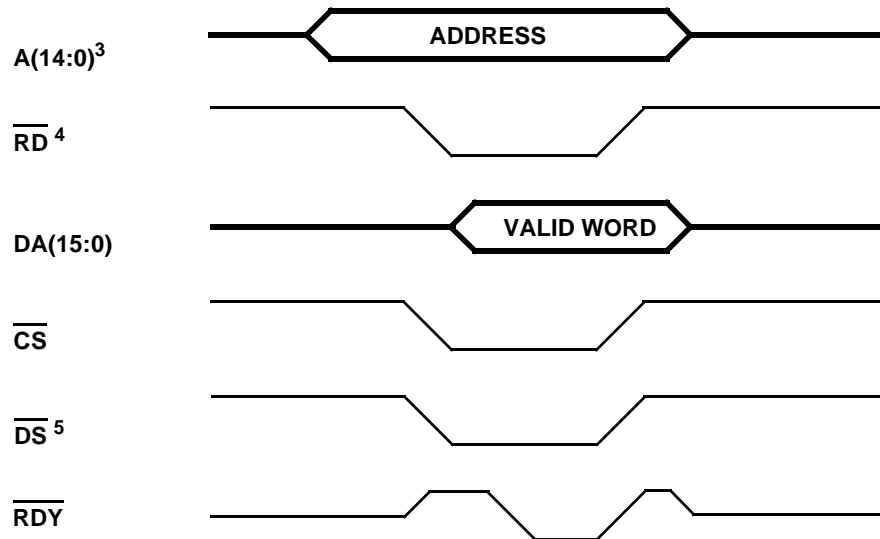

Notes:

1. ALE must be tied high.
2. Latter assertion of $\overline{\text{CS}}$, $\overline{\text{DS}}$, $\overline{\text{RD}}$ starts cycle.
3. A15 must be tied low.
4. When using $\overline{\text{R/WR}}$ as an input signal tie $\overline{\text{RD}}$ to a logical one. During the read cycle $\overline{\text{R/WR}}$ remains a logic 1.
5. $\overline{\text{DS}}$ asserts to signal the SμMMIT XTE to place data on the bus.

Figure 27b. 16-bit Memory and Register Access

Multiplexed Memory Register Write Access (8-bit Mode)¹

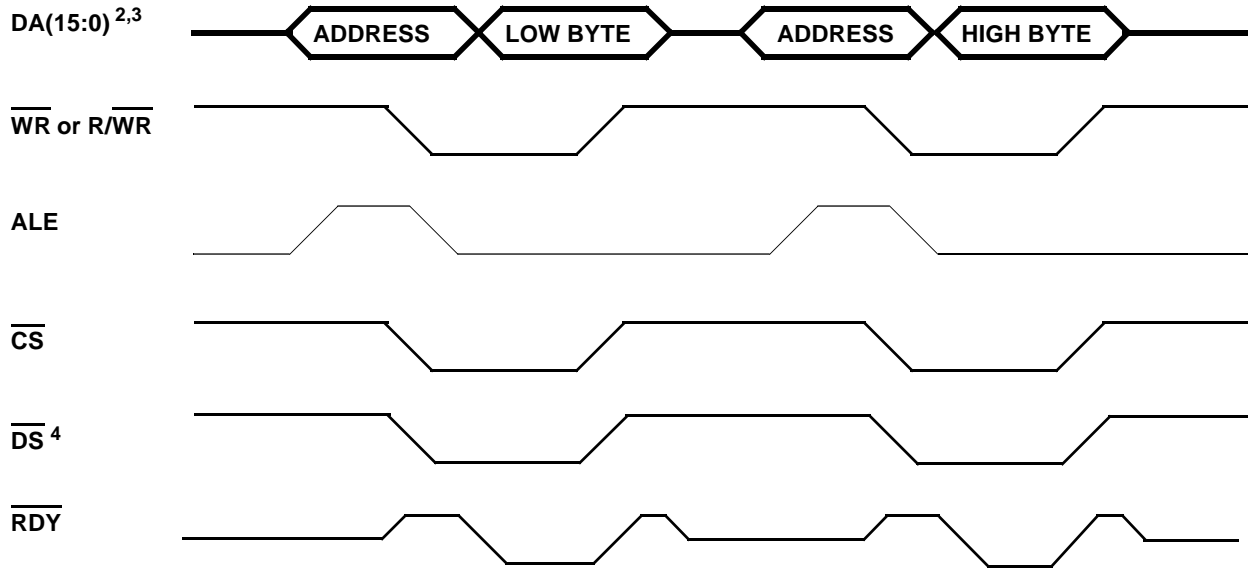

Notes:

1. Latter assertion of \overline{CS} , \overline{DS} , \overline{WR} or R/\overline{WR} starts cycle.
2. For multiplexed address and data interfaces ALE latches the address into the S μ MMIT XTE. Data is applied to inputs DA(7:0), tie A(15:0) to either a logical one or zero.
3. Tie DA(15:8) to V_{SS} via a 10K resistor.
4. \overline{DS} asserts to signal that data is valid on the bus.

Multiplexed Memory/Register Read Access (8-bit Mode)¹

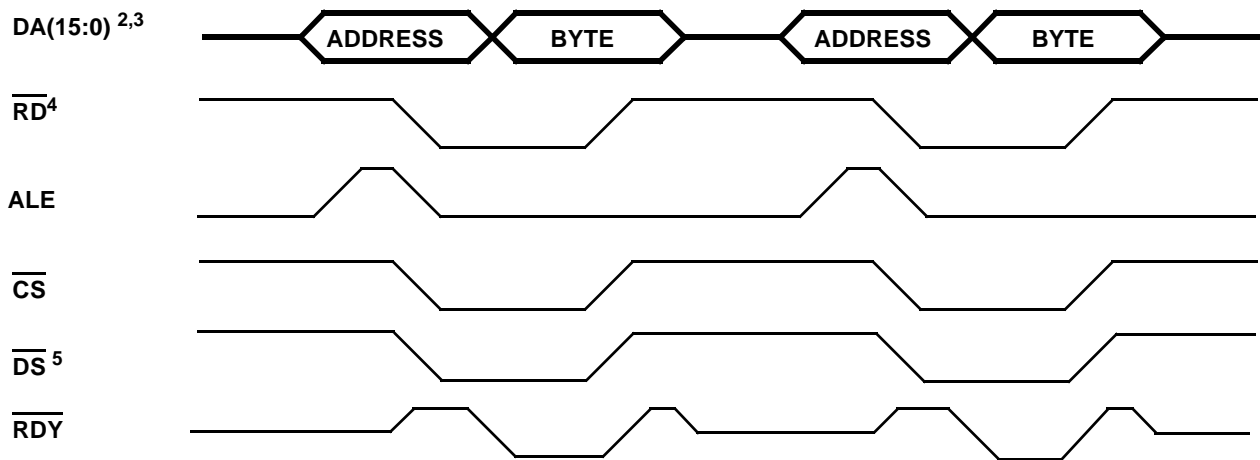

Notes:

1. Latter assertion of \overline{CS} , \overline{DS} , \overline{RD} starts cycle.
2. For multiplexed address and data interfaces ALE latches the address into the S μ MMIT XTE. Data is read from outputs DA(7:0), tie A(15:0) to either a logical one or zero.
3. Tie DA(15:8) to V_{SS} via a 10K resistor.
4. When using R/\overline{WR} as an input signal tie \overline{RD} to a logical one. During the read cycle R/\overline{WR} remains a logic 1.
5. \overline{DS} asserts to signal the S μ MMIT XTE to place data on the bus.

Figure 27c. Multiplexed 8-bit Memory and Register Access

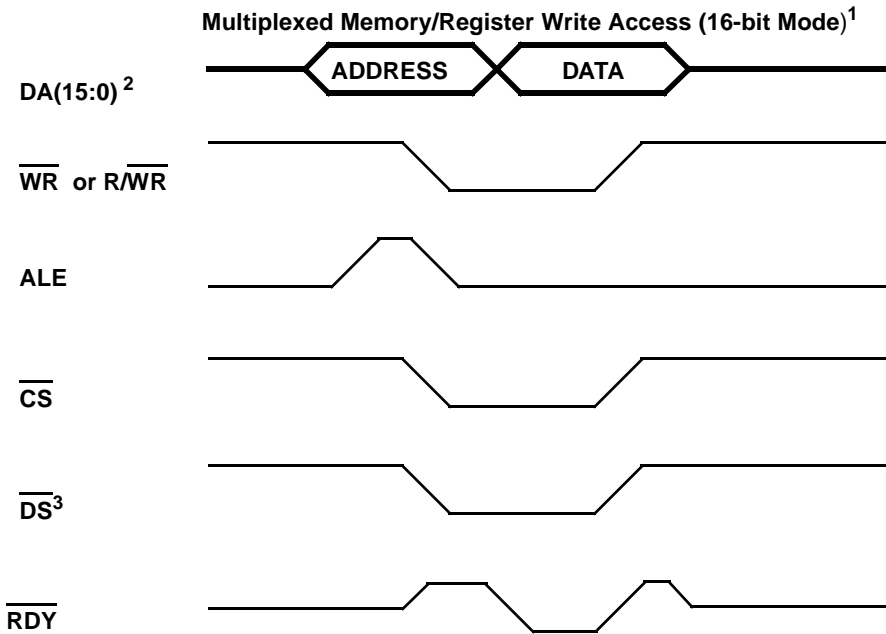

Notes:

1. Latter assertion of $\overline{\text{CS}}$, $\overline{\text{DS}}$, $\overline{\text{WR}}$ or $\overline{\text{R/WR}}$ starts cycle.
2. For multiplexed address and data interfaces ALE latches the address into the S μ MMIT XTE.
Data is applied to inputs DA(15:0), tie A(15:0) to either a logical one or zero.
3. $\overline{\text{DS}}$ asserts to signal that data is valid on the bus.

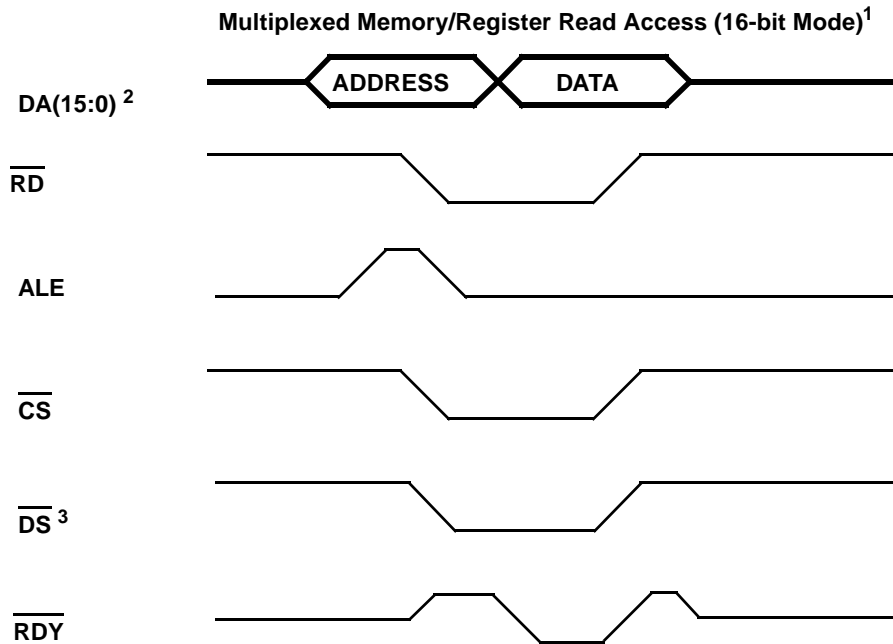

Notes:

1. Latter assertion of $\overline{\text{CS}}$, $\overline{\text{DS}}$, $\overline{\text{RD}}$ starts cycle.
2. For multiplexed address and data interfaces ALE latches the address into the S μ MMIT XTE.
Data is read from outputs DA(15:0), tie A(15:0) to either a logical one or zero.
3. $\overline{\text{DS}}$ asserts to signal the S μ MMIT XTE to place data on the bus.

Figure 27d. Multiplexed 16-bit Memory and Register Access

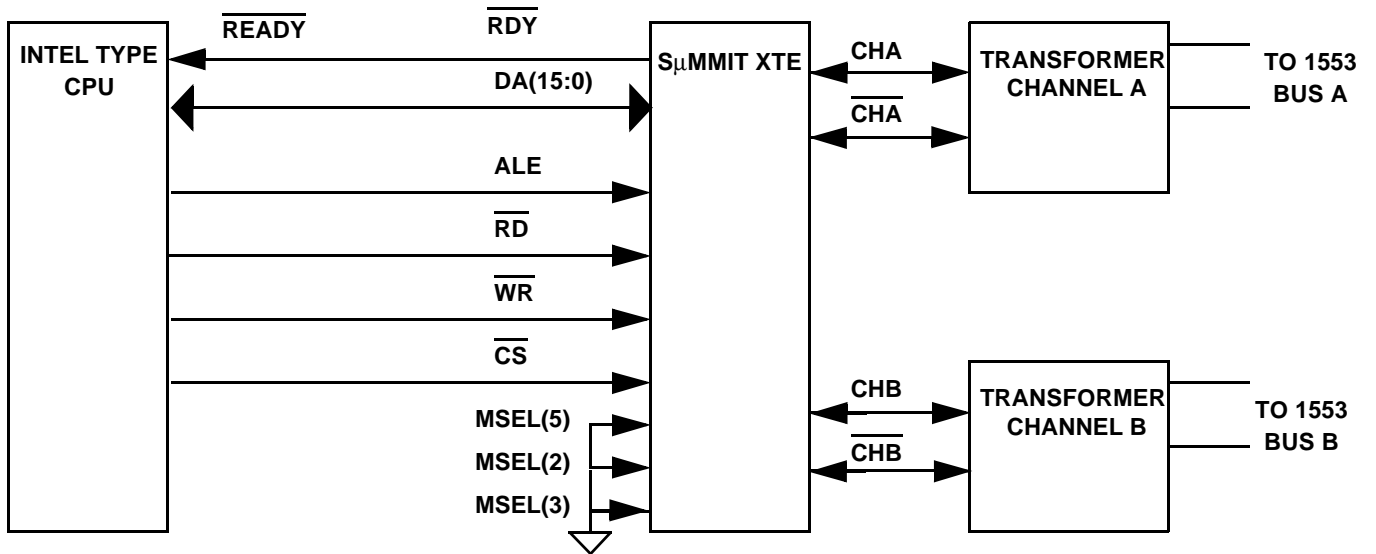

Figure 28a. 16-bit Interface (Intel Type)

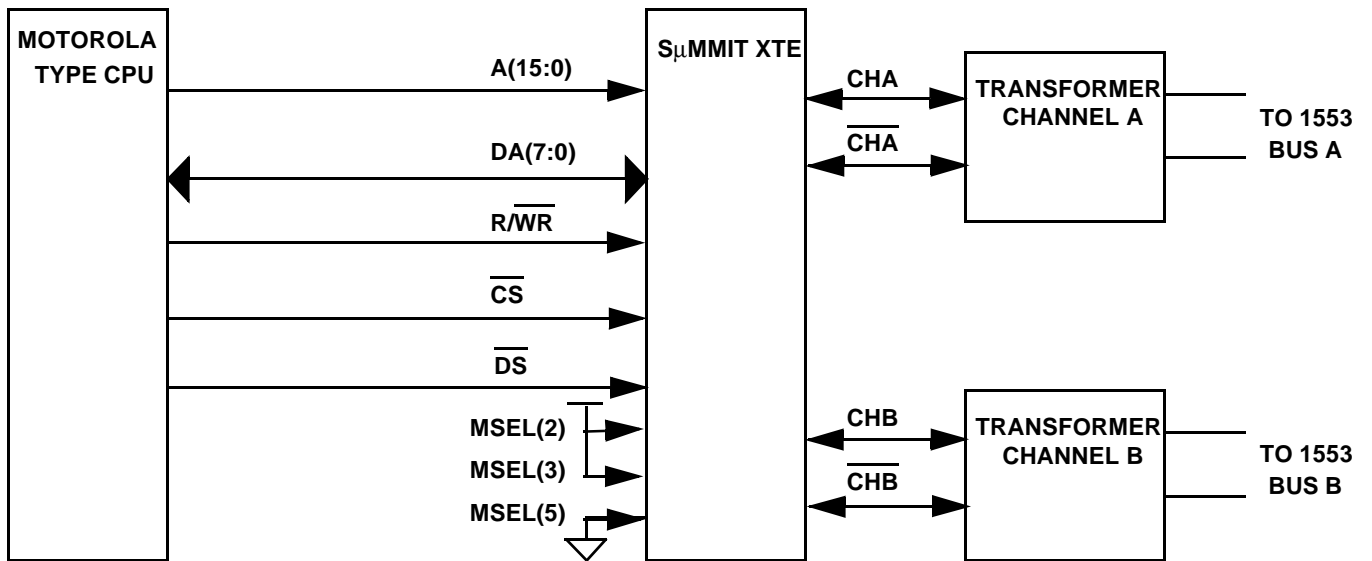

Figure 28b. 16-bit Interface (Motorola Type)

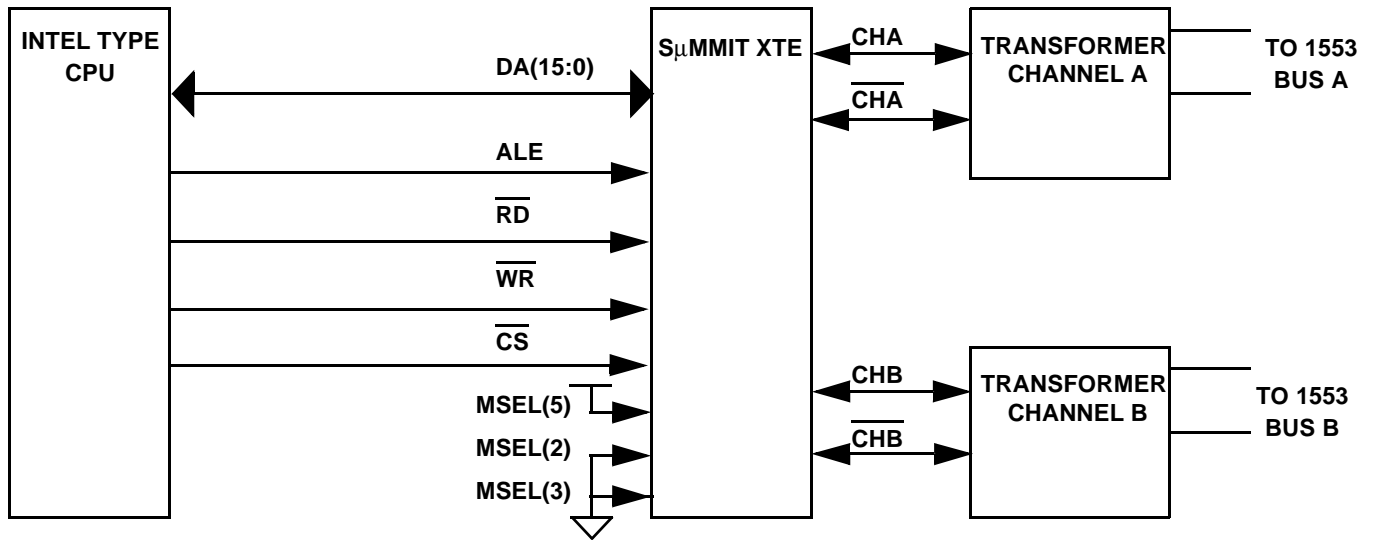

Figure 28c. 8-bit Interface (Intel Type)

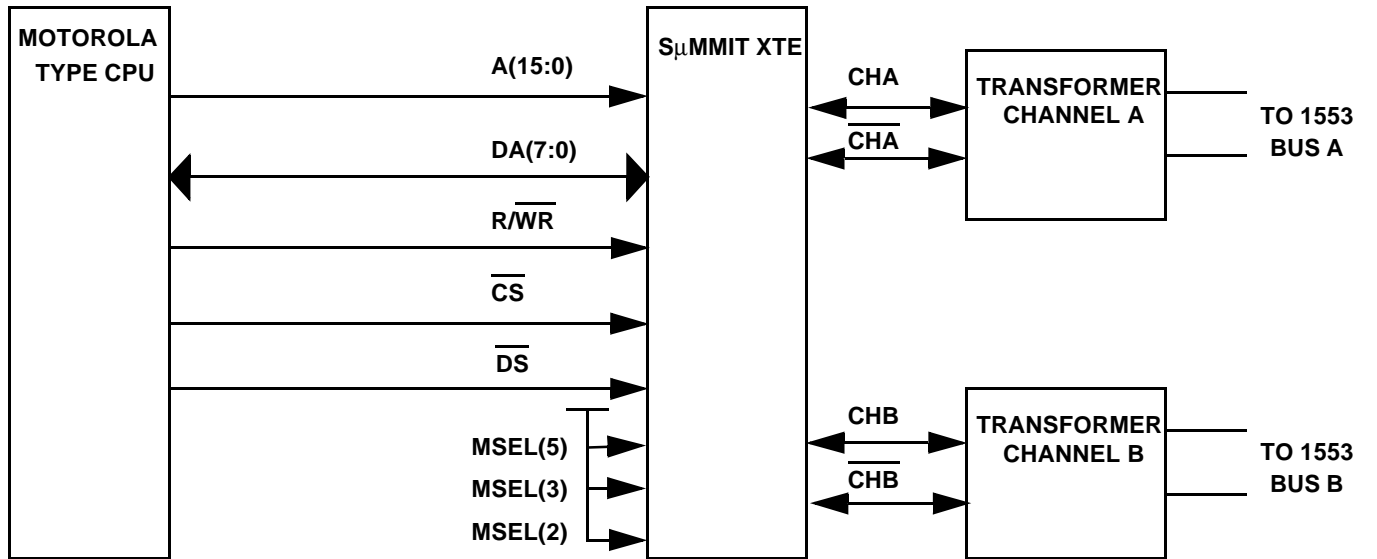

Figure 28d. 8-bit Interface (Motorola Type)

10.0 SERIAL DATA BUS INTERFACE

The S μ MMIT LXE/DXE & S μ MMIT XTE Manchester encoder/decoder interfaces directly to the MIL-STD-1553 bus via transformers, using $\overline{\text{CHA}}$ - $\overline{\text{CHA}}$ and $\overline{\text{CHB}}$ - $\overline{\text{CHB}}$. The designer can connect the S μ MMIT LXE/DXE & S μ MMIT XTE to the data bus via a short-stub (direct-coupling) connection or a long-stub (transformer-coupling) connection. Use a short-stub connection when the distance from the isolation transformer to the data bus does not exceed a one-foot maximum. Use a long-stub connection when the distance from the isolation transformer exceeds the one-foot maximum and is less than twenty feet. Figures 29 a-c show various examples of bus coupling configurations. The S μ MMIT LXE/DXE & S μ MMIT XTE is designed to function with MIL-STD-1553A and 1553B compatible transformers.

10.1 Transmitter

The transmitter section accepts Manchester II biphasic TTL data and converts this data into differential phase-modulated current drive. Transmitter current drivers are coupled to a MIL-STD-

1553 data bus via a transformer driven from the $\overline{\text{CHA}}$ ($\overline{\text{CHB}}$) and $\overline{\text{CHA}}$ ($\overline{\text{CHB}}$) terminals. The S μ MMIT LXE/DXE & S μ MMIT XTE internally generates a signal to the transceiver for the MIL-STD-1553 fail-safe timer requirement.

10.2 Receiver

The receiver section accepts biphasic differential data from a MIL-STD-1553 data bus at its $\overline{\text{CHA}}$ ($\overline{\text{CHB}}$) and $\overline{\text{CHA}}$ ($\overline{\text{CHB}}$) inputs. The receiver converts input data to biphasic Manchester II TTL format at internal RXOUT and $\overline{\text{RXOUT}}$ terminals. The internal outputs RXOUT and $\overline{\text{RXOUT}}$ represent positive and negative excursions (respectively) of the inputs $\overline{\text{CHA}}$ ($\overline{\text{CHB}}$) and $\overline{\text{CHA}}$ ($\overline{\text{CHB}}$).

10.3 Recommended Thermal Protection

All packages should mount to or contact a heat removal rail located in the printed circuit board. To insure proper heat transfer between the package and the heat removal rail, use a thermally-conductive material between the package and the heat removal rail. Use a material such as Mereco XLN-589 or equivalent to insure heat transfer between the package and heat removal rail.

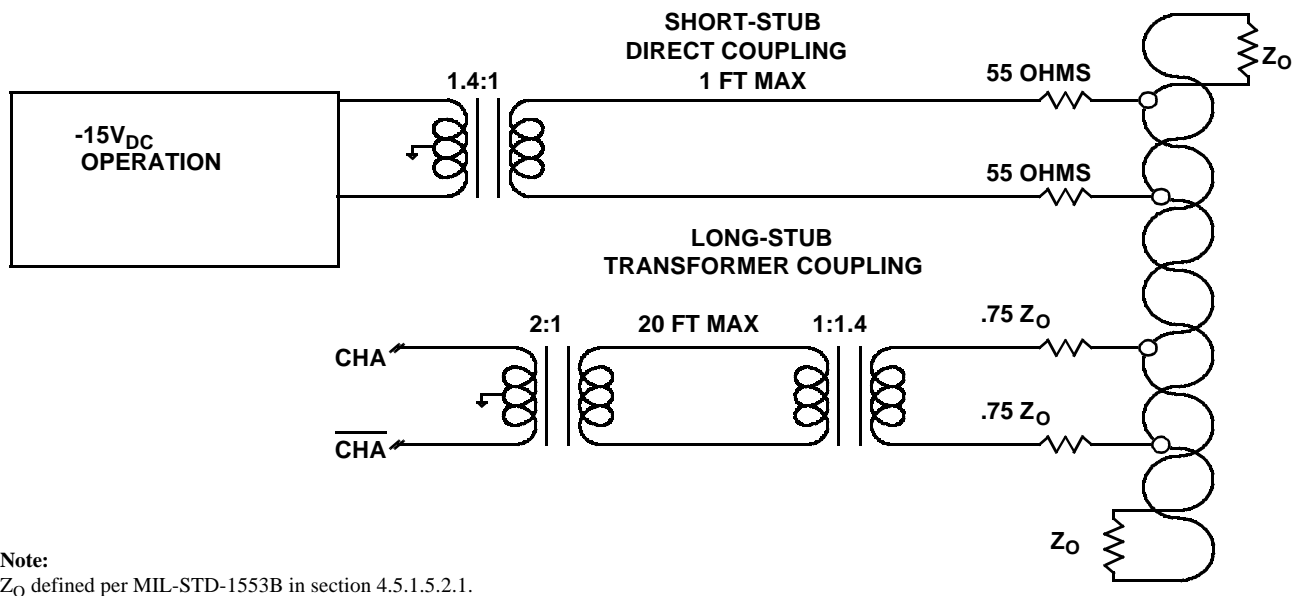

Note:

Z₀ defined per MIL-STD-1553B in section 4.5.1.5.2.1.

Figure 29a. S μ MMIT LXE15, XTE15 Bus Coupling Configuration

Table 19. Transformer Requirements Versus Power Supplies

| COUPLING TECHNIQUE | -12V_{DC} | -15V_{DC} | +5V_{DC} |
|---|--------------------------|--------------------------|-------------------------|
| DIRECT-COUPLED: Isolation | 1.2:1 | 1.4:1 | 1:2.5 |
| TRANSFORMER-COUPLED: Isolation Transformer Ratio | 1.66:1 | 2:1 | 1:1.79 |
| Coupling Transformer Ratio | 1:1.4 | 1:1.4 | 1:1.4 |

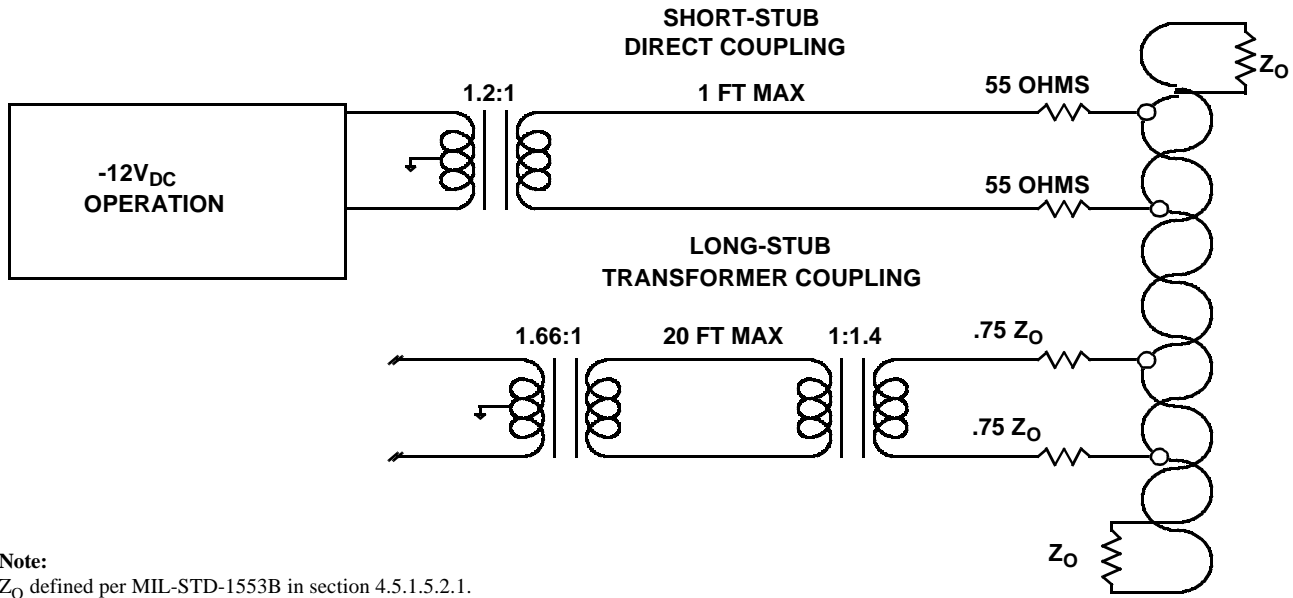

Figure 29b. S μ MMIT LXE12, XTE12 Bus Coupling Configuration

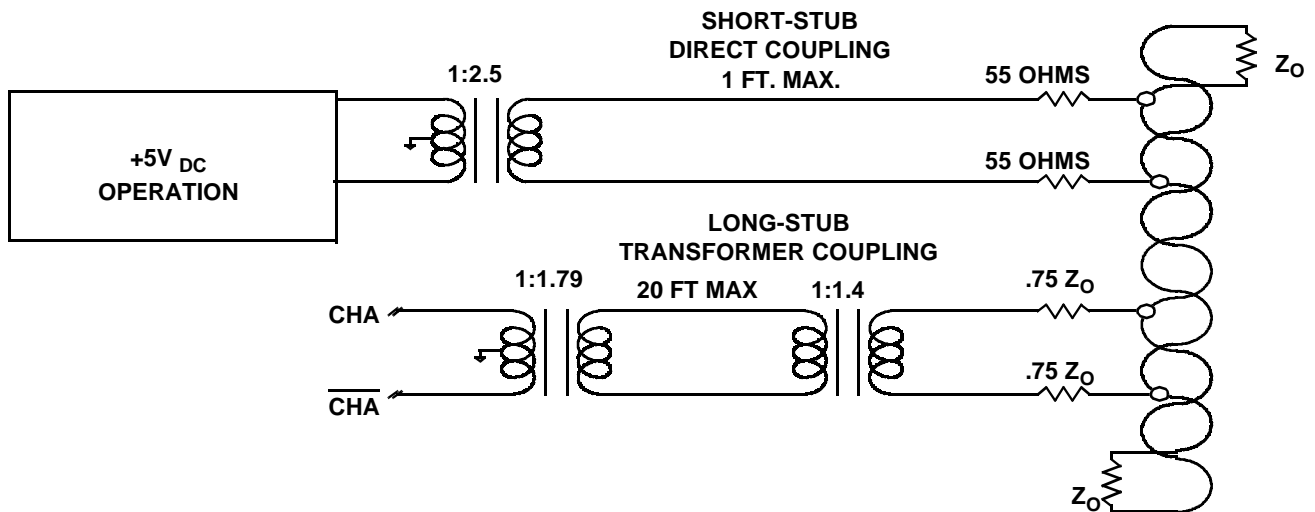

Figure 29c. S μ MMIT DXE, XTE5 Bus Coupling Configuration

11.0 S μ MMIT E PIN IDENTIFICATION AND DESCRIPTION

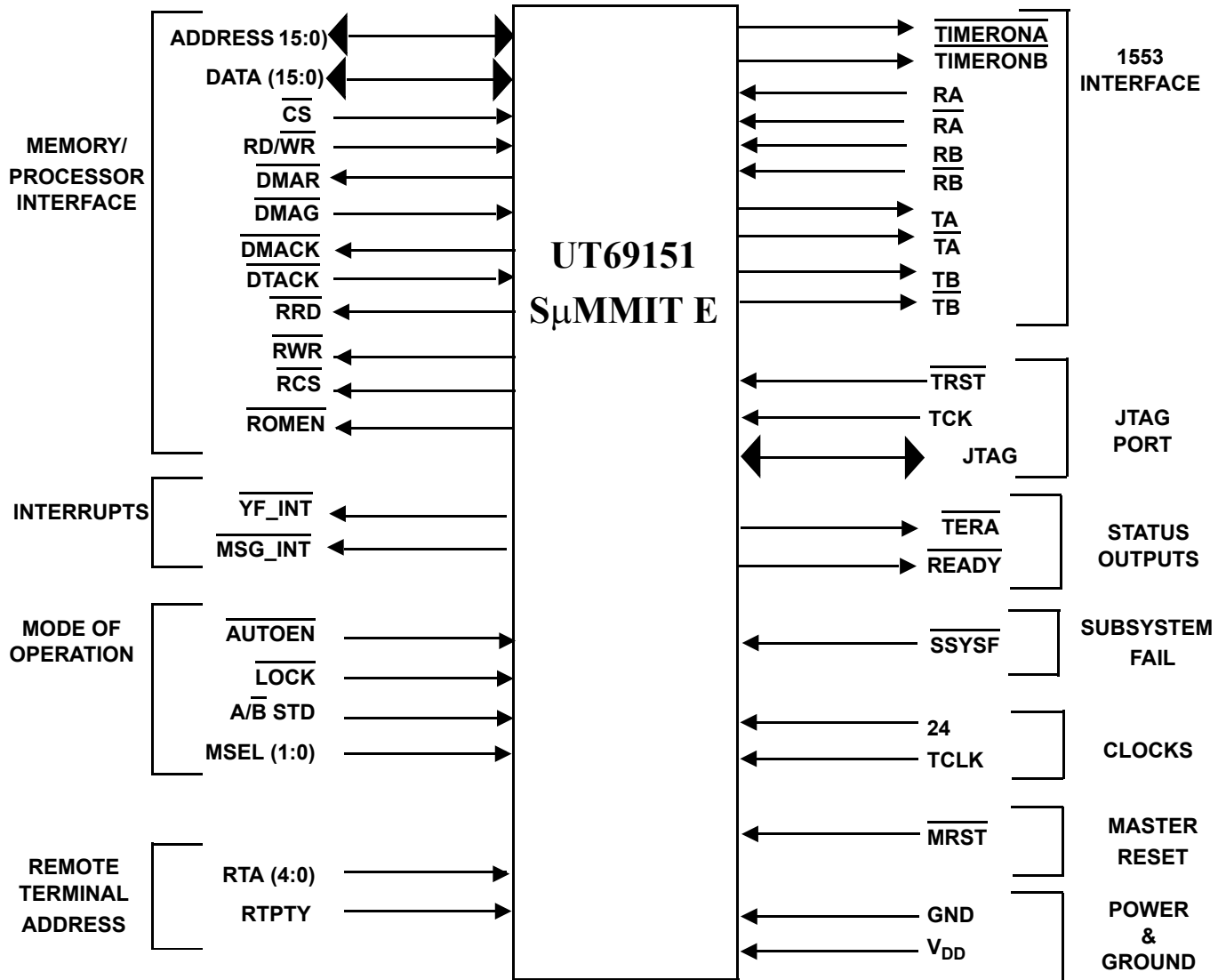

Figure 30. S μ MMIT E Functional Pin Description

11.1 S μ MMIT E Functional Pin Description

Legend for TYPE and ACTIVE fields¹:

TO = TTL output
 TTB = Three-state TTL bidirectional
 CI = CMOS input
 TUI = TTL input (internally pulled high)
 AH = Active high
 AL = Active low
 TI = TTL input
 OD = Open Drain
 TTO = Three-state TTL output
 PGA = Pingrid Array
 FP = Flatpack
 [] = 132-lead Flatpack

Note:

1. All pins described as TTL use CMOS transistors that are designed compatibility with TTL devices.

11.1.1 Data Bus

| Bit Number | Type | Active | Pin Number | | Description |
|------------|------|--------|------------|-----|---|
| | | | FP | PGA | |
| 15 | TTB | -- | 4 [7] | C1 | Bit 15 (MSB) of the bidirectional Data bus. |
| 14 | TTB | -- | 5 [8] | D2 | Bit 14 of the bidirectional Data bus. |
| 13 | TTB | -- | 6 [9] | D1 | Bit 13 of the bidirectional Data bus. |
| 12 | TTB | -- | 7 [10] | F2 | Bit 12 of the bidirectional Data bus. |
| 11 | TTB | -- | 8 [11] | E2 | Bit 11 of the bidirectional Data bus. |
| 10 | TTB | -- | 9 [15] | E1 | Bit 10 of the bidirectional Data bus. |
| 9 | TTB | -- | 10 [18] | F1 | Bit 9 of the bidirectional Data bus. |
| 8 | TTB | -- | 13 [19] | G1 | Bit 8 of the bidirectional Data bus. |
| 7 | TTB | -- | 14 [20] | G2 | Bit 7 of the bidirectional Data bus. |
| 6 | TTB | -- | 15 [24] | G3 | Bit 6 of the bidirectional Data bus. |
| 5 | TTB | -- | 16 [25] | H1 | Bit 5 of the bidirectional Data bus. |
| 4 | TTB | -- | 17 [26] | H2 | Bit 4 of the bidirectional Data bus. |
| 3 | TTB | -- | 18 [27] | J1 | Bit 3 of the bidirectional Data bus. |
| 2 | TTB | -- | 19 [30] | K1 | Bit 2 of the bidirectional Data bus. |
| 1 | TTB | -- | 20 [31] | J2 | Bit 1 of the bidirectional Data bus. |
| 0 | TTB | -- | 21 [32] | L1 | Bit 0 (LSB) of the bidirectional Data bus. |

11.1.2 Address Bus

| Bit Number | Type RadHard | Type Non-RadHard ¹ | Active | Pin Number | | Description |
|------------|--------------|-------------------------------|--------|------------|-----|---|
| | | | | FP | PGA | |
| 15 | TTO | TTB | -- | 64 [101] | B10 | Bit 15 (MSB) of the Address bus. |
| 14 | TTO | TTB | -- | 65 [102] | B9 | Bit 14 of the Address bus. |
| 13 | TTO | TTB | -- | 66 [103] | A10 | Bit 13 of the Address bus. |
| 12 | TTO | TTB | -- | 67 [106] | A9 | Bit 12 of the Address bus. |
| 11 | TTO | TTB | -- | 68 [107] | B8 | Bit 11 of the Address bus. |
| 10 | TTO | TTB | -- | 69 [108] | A8 | Bit 10 of the Address bus. |
| 9 | TTO | TTB | -- | 70 [109] | C7 | Bit 9 of the Address bus. |
| 8 | TTO | TTB | -- | 71 [110] | B7 | Bit 8 of the Address bus. |
| 7 | TTO | TTB | -- | 72 [114] | A7 | Bit 7 of the Address bus. |
| 6 | TTO | TTB | -- | 76 [118] | A5 | Bit 6 of the Address bus. |
| 5 | TTO | TTB | -- | 77 [119] | B5 | Bit 5 of the Address bus. |
| 4 | TTB | TTB | -- | 78 [123] | A6 | Bit 4 of the bidirectional Address bus. |
| 3 | TTB | TTB | -- | 79 [124] | A4 | Bit 3 of the bidirectional Address bus. |
| 2 | TTB | TTB | -- | 80 [125] | B4 | Bit 2 of the bidirectional Address bus. |
| 1 | TTB | TTB | -- | 81 [126] | A3 | Bit 1 of the bidirectional Address bus. |
| 0 | TTB | TTB | -- | 82 [129] | A2 | Bit 0 (LSB) of the bidirectional Address bus. |

Note:

1. Address lines are inputs while $\overline{\text{DMACK}}$ is inactive.

11.1.3 Remote Terminal Address Inputs

| Name | Type | Active | Pin Number | | Description |
|-------|------|--------|------------|-----|---|
| | | | FP | PGA | |
| RTA4 | TUI | -- | 37 [58] | L8 | Remote terminal Address Bit 4. This is the most significant bit for the RT address. |
| RTA3 | TUI | -- | 38 [59] | K8 | Remote Terminal Address Bit 3. This is bit 3 of the RT address. |
| RTA2 | TUI | -- | 39 [60] | L9 | Remote Terminal Address bit 2. This is bit 2 of the RT address. |
| RTA1 | TUI | -- | 40 [63] | L10 | Remote Terminal Address Bit 1. This is bit 1 of the RT address. |
| RTA0 | TUI | -- | 41 [64] | K9 | Remote Terminal Address Bit 0. This is bit 0 of the RT address. This is the least significant bit for the RT address. |
| RTPTY | TUI | -- | 42 [65] | L11 | Remote Terminal Parity. This is an odd parity input for the RT address. |

11.1.4 JTAG Testability Pins

| Name | Type | Active | Pin Number | | Description |
|--------------------------|------|--------|------------|-----|--|
| | | | FP | PGA | |
| TDO | TTO | -- | 49 [79] | G9 | TDO. This output performs the operation of Test Data Output as defined in the IEEE Standard 1149.1. This non-inverting output buffer is optimized for driving TTL loads. |
| TCK | TUI | -- | 54 [84] | E9 | TCK. This input performs the operation of Test Clock input as defined in the IEEE Standard 1149.1. This non-inverting input buffer is optimized for driving TTL input levels. Can operate up to 1MHz. |
| TMS | TUI | -- | 51 [81] | G11 | TMS. This input performs the operation of Test Mode Select as defined in the IEEE Standard 1149.1. This non-inverting input buffer is optimized for driving TTL input levels. |
| TDI | TUI | -- | 50 [80] | G10 | TDI. This input performs the operation of Test Data In as defined in the IEEE Standard 1149.1. This non-inverting input buffer is optimized for driving TTL input levels. |
| $\overline{\text{TRST}}$ | TUI | AL | 48 [78] | H11 | $\overline{\text{TRST}}$. This input provides the RESET to the TAP controller as defined in the IEEE Standard 1149.1. This non-inverting input buffer is optimized for driving TTL input levels. When not exercising JTAG, tie $\overline{\text{TRST}}$ to a logical 0. |

11.1.5 Biphase Inputs

| Name | Type | Active | Pin Number | | Description |
|------------------------|------|--------|------------|-----|--|
| | | | FP | PGA | |
| RA | TI | -- | 26 [41] | K4 | Receive Channel A (True). This is the Manchester-encoded true signal input for channel A. (Quiescent low). |
| $\overline{\text{RA}}$ | TI | -- | 25 [38] | L3 | Receive Channel A (Complement). This is the Manchester-encoded complement signal input for channel A. (Quiescent low). |
| RB | TI | -- | 33 [51] | J5 | Receive Channel B (True). This is the Manchester-encoded true signal input for channel B. (Quiescent low). |
| $\overline{\text{RB}}$ | TI | -- | 30 [48] | L5 | Receive Channel B (Complement). This is the Manchester-encoded complement signal input for channel B. (Quiescent low). |

11.1.6 Biphase Outputs

| Name | Type | Active | Pin Number | | Description |
|-----------------|-----------------|--------|------------|-----|--|
| | | | FP | PGA | |
| TA | TO ¹ | -- | 24 [37] | L2 | Transmit Channel A (True). This is the Manchester-encoded true signal output for channel A. The signal is idle low. (Quiescent low). |
| \overline{TA} | TO ¹ | -- | 23 [36] | K3 | Transmit Channel A (Complement). This is the Manchester-encoded complement signal output for channel A. The signal is idle low. (Quiescent low). |
| TB | TO ¹ | -- | 29 [44] | K5 | Transmit Channel B (True). This is the Manchester-encoded true signal output for channel B. The signal is idle low. (Quiescent low). |
| \overline{TB} | TO ¹ | -- | 28 [43] | K6 | Transmit Channel B (Complement). This is the Manchester-encoded complement signal output for channel B. The signal is idle low. (Quiescent low). |

Note:

1. These pins are driven low while \overline{MRST} is low and 24MHz is active.

11.1.7 DMA Signals

| Name | Type | Active | Pin Number | | Description |
|--------------------|-----------------|--------|------------|-----|--|
| | | | FP | PGA | |
| \overline{DMAR} | OD ¹ | AL | 55 [85] | E11 | DMA Request. This signal is asserted when access to RAM is required. It goes inactive upon receipt of the \overline{DMAG} signal. |
| \overline{DMAG} | TI | AL | 56 [86] | E10 | DMA Grant. Once this input is received, the S μ MMIT is allowed to access RAM. |
| \overline{DMACK} | OD ¹ | AL | 57 [90] | F11 | DMA Acknowledge. This signal is asserted by the S μ MMIT to indicate the receipt of \overline{DMAG} . The signal remains active until all RAM bus activity is completed. |
| \overline{DTACK} | TI | AL | 3 [4] | B1 | Data Transfer Acknowledge. This pin indicates that a data transfer is to occur and that the S μ MMIT may complete the memory cycle. |

Note:

1. This output will drive low and three-state only.

11.1.8 Control Signals

| Name | Type | Active | Pin Number | | Description | | | | | | | | | | | | | | | |
|----------------------------|-----------------|------------------------|------------|-----|---|---------|---------|-------------------|---|---|----------------------|---|---|-----------------------|---|---|------------------------|---|---|---------|
| | | | FP | PGA | | | | | | | | | | | | | | | | |
| RD/ $\overline{\text{WR}}$ | TI | -- | 63 [98] | A11 | Read/Write. This indicates the direction of data flow with respect to the host. A logic high signal means the host is trying to read data from the S μ MMIT, and a logic low signal means the host is trying to write data to the S μ MMIT. | | | | | | | | | | | | | | | |
| $\overline{\text{CS}}$ | TI | AL | 62 [97] | C10 | Chip Select. This pin selects the S μ MMIT when accessing the internal registers. | | | | | | | | | | | | | | | |
| $\overline{\text{RRD}}$ | TTO | AL | 84 [131] | A1 | RAM Read. This signal is generated by the S μ MMIT to read data from RAM. | | | | | | | | | | | | | | | |
| $\overline{\text{RWR}}$ | TTO | AL | 83 [130] | B3 | RAM Write. This signal is generated by the S μ MMIT to write data to RAM. | | | | | | | | | | | | | | | |
| $\overline{\text{RCS}}$ | TTO | AL | 1 [2] | B2 | RAM Chip Select. This signal is used in conjunction with the $\overline{\text{RRD}}/\overline{\text{RWR}}$ signals to access RAM. | | | | | | | | | | | | | | | |
| $\overline{\text{AUTOEN}}$ | TUI | AL | 60 [93] | C11 | Auto Enable. This pin, when active, enables automatic initialization. | | | | | | | | | | | | | | | |
| $\overline{\text{ROMEN}}$ | OD ¹ | AL | 61 [96] | B11 | ROM Enable. This pin, when active, enables the ROM for automatic initialization applications. | | | | | | | | | | | | | | | |
| $\overline{\text{SSYSF}}$ | TUI | AL | 36 [57] | J7 | Subsystem Fail. Upon receipt, this signal propagates directly to the RT 1553 Status Word. | | | | | | | | | | | | | | | |
| 24 MHz | CI | -- | 75 [117] | C5 | 24 MHz Clock. The 24MHz input clock requires a 50% \pm 5% duty cycle with an accuracy of \pm 0.01%. See Appendix A on UT54ACTS220 Clock Generator. | | | | | | | | | | | | | | | |
| $\overline{\text{MRST}}$ | TUI | AL | 47 [75] | H10 | Master Reset. This input pin resets the internal encoders, decoders, all registers, and associated logic. | | | | | | | | | | | | | | | |
| MSEL(1) | TI | -- | 45 [73] | K11 | Mode Select 1. This pin is the most significant bit for the mode select. For proper mode selection, see below: <table style="margin-left: auto; margin-right: auto;"> <thead> <tr> <th>MSEL(1)</th> <th>MSEL(0)</th> <th>Mode of Operation</th> </tr> </thead> <tbody> <tr> <td>0</td> <td>0</td> <td>Bus Controller = SBC</td> </tr> <tr> <td>0</td> <td>1</td> <td>Remote Terminal = SRT</td> </tr> <tr> <td>1</td> <td>0</td> <td>Monitor Terminal = SMT</td> </tr> <tr> <td>1</td> <td>1</td> <td>SMT/SRT</td> </tr> </tbody> </table> | MSEL(1) | MSEL(0) | Mode of Operation | 0 | 0 | Bus Controller = SBC | 0 | 1 | Remote Terminal = SRT | 1 | 0 | Monitor Terminal = SMT | 1 | 1 | SMT/SRT |
| MSEL(1) | MSEL(0) | Mode of Operation | | | | | | | | | | | | | | | | | | |
| 0 | 0 | Bus Controller = SBC | | | | | | | | | | | | | | | | | | |
| 0 | 1 | Remote Terminal = SRT | | | | | | | | | | | | | | | | | | |
| 1 | 0 | Monitor Terminal = SMT | | | | | | | | | | | | | | | | | | |
| 1 | 1 | SMT/SRT | | | | | | | | | | | | | | | | | | |
| MSEL(0) | TI | -- | 46 [74] | J11 | Mode Select 0. This pin is the least significant bit for the mode select. (See MSEL1 for proper logic states.) | | | | | | | | | | | | | | | |

Note:

1. This output will drive low and three-state only.

11.1.8 Control Signals (continued)

| Name | Type | Active | Pin Number | | Description |
|---------|------|--------|------------|-----|---|
| | | | FP | PGA | |
| TCLK | TI | -- | 2 [3] | C2 | Timer Clock. The internal timer is a 16-bit counter with a 64 μ s resolution when using the 24MHz input clock. For different applications, the user may input a clock (0-6MHz) to establish the timer resolution. (Duty Cycle = 50% \pm 10%). |
| A/B STD | TUI | -- | 44 [69] | J10 | Military Standard A or B. This pin defines whether the S μ MMIT will be used in a MIL-STD-1553A or 1553B mode of operation. |
| LOCK | TUI | AL | 43 [68] | K10 | Lock. This pin, when set active, prevents software changes to both the RT address, A/B STD, and mode select. |

Note:

1. High impedance and active low.

11.1.9 Status Signals

| Name | Type | Active | Pin Number | | Description |
|-----------|-----------------|--------|------------|-----|--|
| | | | FP | PGA | |
| TERACT | TO ² | AL | 34 [52] | L7 | Terminal Active. This output pin indicates that the terminal is actively processing a 1553 command. |
| TIMER ONA | TO ² | AL | 22 [35] | K2 | Timer On A. This is a 800 μ s fail-safe transmitter enable timer for channel A. This output is reset on receipt of a new command or after 760 μ s. |
| TIMER ONB | TO ² | AL | 27 [42] | L4 | Timer On B. This is a 800 μ s fail-safe transmitter enable timer for channel B. This output is reset on receipt of a new command or after 760ms. |
| MSG_INT | OD ¹ | AL | 58 [91] | D11 | Message Interrupt. This pin is active for three clock cycles (i.e., 125ns pulse) upon the occurrence of interrupt events which are enabled. |
| YF_INT | OD ¹ | AL | 59 [92] | D10 | You Failed Interrupt. This pin is active for three clock cycles (i.e., 125ns pulse) upon the occurrence of interrupt events which are enabled. |
| READY | TO ² | AL | 35 [53] | K7 | Ready. This signal indicates the S μ MMIT has completed a reset, an auto-initialization, or a BIT. After assertion of the READY signal initialization of the S μ MMIT for operation can begin. |

Note:

1. This output will drive low and three-state only.
2. These pins are driven high while MRST is low and 24MHz is active.

11.1.10 Power/Ground

The following shows the package location of all power and ground pins associated with the S μ MMIT.

| Pin Number | Pin Number | | Description |
|-----------------|--|-----------------|------------------------------|
| | FP | PGA | |
| V _{DD} | 12, 32, 53, 73 [17], [34], [50], [66], [83], [100], [115], [132] | E3, L6, F9, C6 | +5 Volt Power ($\pm 10\%$) |
| V _{SS} | 11, 31, 52, 74 [1], [16], [33], [49], [67], [82], [99], [116] | F3, J6, F10, B6 | Digital Ground |

11.1.11 No Connects

| Pin Number | Pin Number | | Description |
|------------|--|-----|-------------|
| | FP | PGA | |
| NC | [5], [6], [12], [13], [14], [21], [22], [23], [28], [29], [39], [40], [45], [46], [47], [54], [55], [56], [61], [62], [70], [71], [72], [76], [77], [87], [88], [89], [94], [95], [104], [105], [111], [112], [113], [120], [121], [122], [127], [128] | NA | No Connects |

12.0 S μ MMIT LXE/DXE PIN IDENTIFICATION AND DESCRIPTION

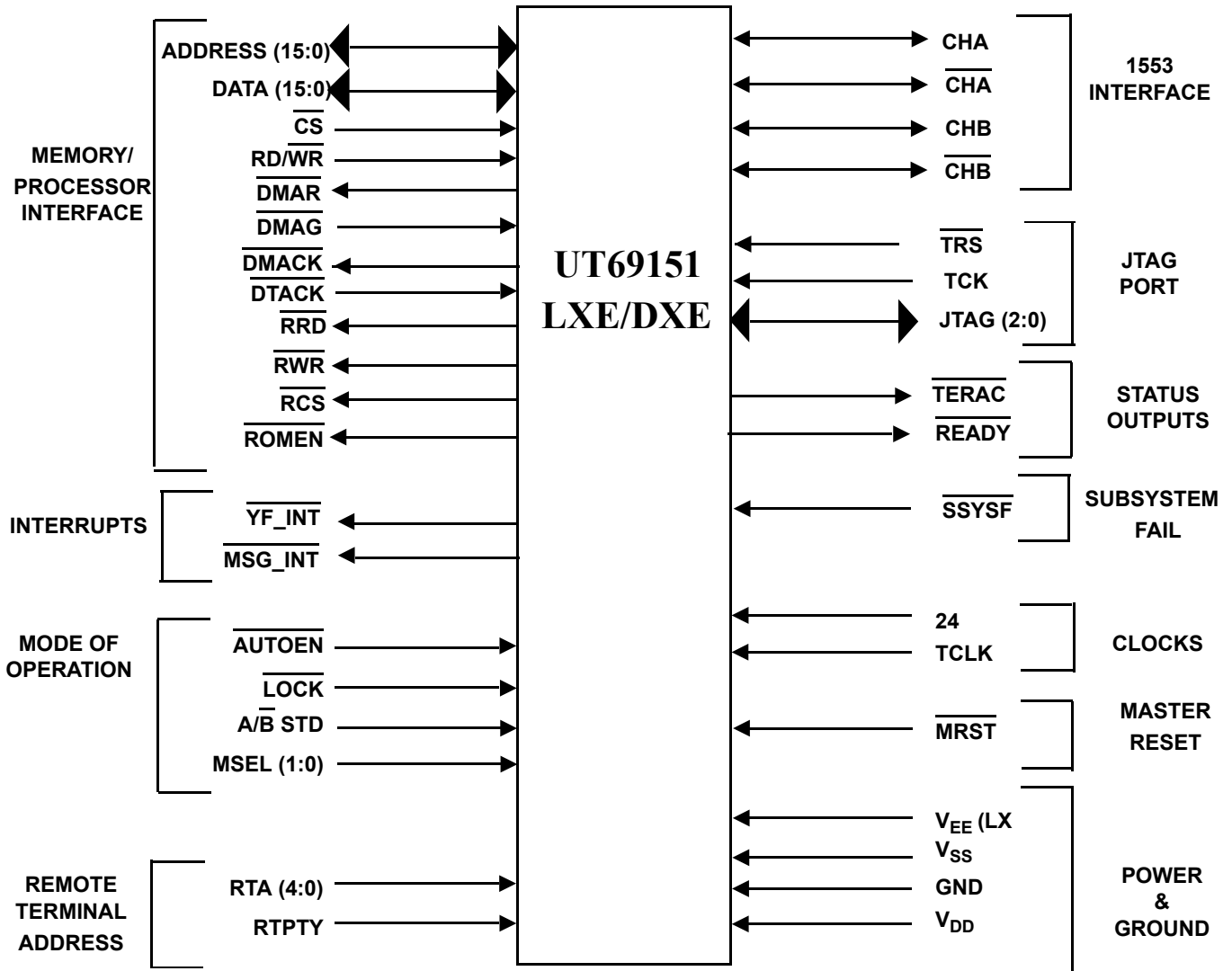

Figure 31. S μ MMIT LXE/DXE Functional Pin Description

12.1 S μ MMIT LXE/DXE Pin Functional Description

Legend for TYPE and ACTIVE fields¹:

TO = TTL output
 TTB = Three-state TTL bidirectional
 CI = CMOS input
 TUI = TTL input (internally pulled high)
 AH = Active high
 AL = Active low
 TI = TTL input
 OD = Open drain
 TTO = Three-state TTL output
 PGA = Pingrid Array
 FP = Flatpack
 DIO = Differential input/output

Note:

1. All pins described as TTL use CMOS transistors that are designed compatibility with TTL devices.

12.1.1 Data Bus

| Bit Number | Type | Active | Pin Number | | Description |
|------------|------|--------|------------|-----|---|
| | | | FP | PGA | |
| 15 | TTB | -- | 97 | V11 | Bit 15 (MSB) of the bidirectional Data bus. |
| 14 | TTB | -- | 96 | V5 | Bit 14 of the bidirectional Data bus. |
| 13 | TTB | -- | 95 | V9 | Bit 13 of the bidirectional Data bus. |
| 12 | TTB | -- | 94 | U10 | Bit 12 of the bidirectional Data bus. |
| 11 | TTB | -- | 93 | U12 | Bit 11 of the bidirectional Data bus. |
| 10 | TTB | -- | 92 | V15 | Bit 10 of the bidirectional Data bus. |
| 9 | TTB | -- | 91 | V13 | Bit 9 of the bidirectional Data bus. |
| 8 | TTB | -- | 90 | V17 | Bit 8 of the bidirectional Data bus. |
| 7 | TTB | -- | 89 | W18 | Bit 7 of the bidirectional Data bus. |
| 6 | TTB | -- | 88 | W16 | Bit 6 of the bidirectional Data bus. |
| 5 | TTB | -- | 87 | W14 | Bit 5 of the bidirectional Data bus. |
| 4 | TTB | -- | 86 | W20 | Bit 4 of the bidirectional Data bus. |
| 3 | TTB | -- | 85 | W22 | Bit 3 of the bidirectional Data bus. |
| 2 | TTB | -- | 84 | V21 | Bit 2 of the bidirectional Data bus. |
| 1 | TTB | -- | 83 | V19 | Bit 1 of the bidirectional Data bus. |
| 0 | TTB | -- | 82 | V23 | Bit 0 (LSB) of the bidirectional Data bus. |

12.1.2 Address Bus

| Bit Number | Type RadHard | Type Non-RadHard ¹ | Active | Pin Number | | Description |
|------------|--------------|-------------------------------|--------|------------|-----|---|
| | | | | FP | PGA | |
| 15 | TTO | TTB | -- | 26 | A2 | Bit 15 (MSB) of the Address bus. |
| 14 | TTO | TTB | -- | 25 | A4 | Bit 14 of the Address bus. |
| 13 | TTO | TTB | -- | 24 | A6 | Bit 13 of the Address bus. |
| 12 | TTO | TTB | -- | 23 | C2 | Bit 12 of the Address bus. |
| 11 | TTO | TTB | -- | 22 | B3 | Bit 11 of the Address bus. |
| 10 | TTO | TTB | -- | 21 | B5 | Bit 10 of the Address bus. |
| 9 | TTO | TTB | -- | 20 | D1 | Bit 9 of the Address bus. |
| 8 | TTO | TTB | -- | 19 | C6 | Bit 8 of the Address bus. |
| 7 | TTO | TTB | -- | 18 | D3 | Bit 7 of the Address bus. |
| 6 | TTO | TTB | -- | 17 | T7 | Bit 6 of the Address bus. |
| 5 | TTO | TTB | -- | 16 | W2 | Bit 5 of the Address bus. |
| 4 | TTB | TTB | -- | 15 | T3 | Bit 4 of the bidirectional Address bus. |
| 3 | TTB | TTB | -- | 14 | T1 | Bit 3 of the bidirectional Address bus. |
| 2 | TTB | TTB | -- | 13 | U6 | Bit 2 of the bidirectional Address bus. |
| 1 | TTB | TTB | -- | 12 | U2 | Bit 1 of the bidirectional Address bus. |
| 0 | TTB | TTB | -- | 11 | W6 | Bit 0 (LSB) of the bidirectional Address bus. |

Note:

1. Address lines are inputs while $\overline{\text{DMACK}}$ is inactive.

12.1.3 Remote Terminal Address Inputs

| Name | Type | Active | Pin Number | | Description |
|-------|------|--------|------------|-----|---|
| | | | FP | PGA | |
| RTA4 | TUI | -- | 59 | B17 | Remote terminal Address Bit 4. This is the most significant bit for the RT address. |
| RTA3 | TUI | -- | 58 | B19 | Remote Terminal Address Bit 3. This is bit 3 of the RT address. |
| RTA2 | TUI | -- | 57 | A20 | Remote Terminal Address bit 2. This is bit 2 of the RT address. |
| RTA1 | TUI | -- | 56 | B21 | Remote Terminal Address Bit 1. This is bit 1 of the RT address. |
| RTA0 | TUI | -- | 55 | A22 | Remote Terminal Address Bit 0. This is bit 0 of the RT address. This is the least significant bit for the RT address. |
| RTPTY | TUI | -- | 54 | B23 | Remote Terminal Parity. This is an odd parity input for the RT address. |

12.1.4 JTAG Testability Pins

| Name | Type | Active | Pin Number | | Description |
|--------------------------|------|--------|------------|-----|--|
| | | | FP | PGA | |
| TDO | TTO | -- | 52 | A18 | TDO. This output performs the operation of Test Data Output as defined in the IEEE Standard 1149.1. This non-inverting output buffer is optimized for driving TTL loads. |
| TCK | TI | -- | 49 | A14 | TCK. This input performs the operation of Test Clock input as defined in the IEEE Standard 1149.1. This non-inverting input buffer is optimized for driving TTL input levels. Can operate up to 1MHz. |
| TMS | TUI | -- | 50 | C14 | TMS. This input performs the operation of Test Mode Select as defined in the IEEE Standard 1149.1. This non-inverting input buffer is optimized for driving TTL input levels. |
| TDI | TUI | -- | 51 | A16 | TDI. This input performs the operation of Test Data In as defined in the IEEE Standard 1149.1. This non-inverting input buffer is optimized for driving TTL input levels. |
| $\overline{\text{TRST}}$ | TUI | AL | 53 | B15 | $\overline{\text{TRST}}$. This input provides the RESET to the TAP controller as defined in the IEEE Standard 1149.1. This non-inverting input buffer is optimized for driving TTL input levels. When not exercising JTAG, tie $\overline{\text{TRST}}$ to a logical 0. |

12.1.5 Biphase Inputs/Outputs

| Name | Type | Active | Pin Number | | Description |
|-------------------------|------|--------|------------|-----|---|
| | | | FP | PGA | |
| CHA | DIO | -- | 32 | U22 | Channel A (True). This is the Manchester-encoded true signal for channel A. |
| $\overline{\text{CHA}}$ | DIO | -- | 33 | U18 | Channel A (Complement). This is the Manchester-encoded complement signal input for channel A. |
| CHB | DIO | -- | 42 | C22 | Channel B (True). This is the Manchester-encoded true signal for channel B. |
| $\overline{\text{CHB}}$ | DIO | -- | 43 | C18 | Channel B (Complement). This is the Manchester-encoded complement signal for channel B. |

12.1.6 DMA Signals

| Name | Type | Active | Pin Number | | Description |
|---------------------------|-----------------|--------|------------|-----|---|
| | | | FP | PGA | |
| $\overline{\text{DMAR}}$ | OD ¹ | AL | 3 | D13 | DMA Request. This signal is asserted when access to RAM is required. It goes inactive upon receipt of the $\overline{\text{DMAG}}$ signal. |
| $\overline{\text{DMAG}}$ | TI | AL | 2 | C10 | DMA Grant. Once this input is received, the S μ MMIT LX/DX is allowed to access RAM. |
| $\overline{\text{DMACK}}$ | OD ¹ | AL | 1 | B7 | DMA Acknowledge. This signal is asserted by the S μ MMIT LX/DX to indicate the receipt of $\overline{\text{DMAG}}$. The signal remains active until all RAM bus activity is completed. |
| $\overline{\text{DTACK}}$ | TI | AL | 4 | V7 | Data Transfer Acknowledge. This pin indicates that a data transfer is to occur and that the S μ MMIT LX/DX may complete the memory cycle. |

Note:

1. This output will drive low and three-state only.

12.1.7 Control Signals

| Name | Type | Active | Pin Number | | Description | | | | | | | | | | | | | | | |
|----------------------------|-----------------|------------------------|------------|-----|---|---------|---------|-------------------|---|---|----------------------|---|---|-----------------------|---|---|------------------------|---|---|---------|
| | | | FP | PGA | | | | | | | | | | | | | | | | |
| RD/ $\overline{\text{WR}}$ | TI | -- | 81 | B11 | Read/Write. This indicates the direction of data flow with respect to the host. A logic high signal means the host is trying to read data from the S μ MMIT LX/DX, and a logic low signal means the host is trying to write data to the S μ MMIT LX/DX. | | | | | | | | | | | | | | | |
| $\overline{\text{CS}}$ | TI | AL | 80 | A10 | Chip Select. This pin selects the S μ MMIT LX/DX when accessing the internal registers. | | | | | | | | | | | | | | | |
| $\overline{\text{RRD}}$ | TTO | AL | 6 | V3 | RAM Read. This signal is generated by the S μ MMIT LX/DX to read data from RAM. | | | | | | | | | | | | | | | |
| $\overline{\text{RWR}}$ | TTO | AL | 7 | W4 | RAM Write. This signal is generated by the S μ MMIT LX/DX to write data to RAM. | | | | | | | | | | | | | | | |
| $\overline{\text{RCS}}$ | TTO | AL | 8 | W12 | RAM Chip Select. This signal is used in conjunction with the $\overline{\text{RRD}}$ / $\overline{\text{RWR}}$ signals to access RAM. | | | | | | | | | | | | | | | |
| $\overline{\text{AUTOEN}}$ | TI | AL | 79 | B9 | Auto Enable. This pin, when active, enables automatic initialization. | | | | | | | | | | | | | | | |
| $\overline{\text{ROMEN}}$ | OD ¹ | AL | 78 | A8 | ROM Enable. This pin, when active, enables the ROM for automatic initialization applications. | | | | | | | | | | | | | | | |
| $\overline{\text{SSYSF}}$ | TUI | AL | 75 | U14 | Subsystem Fail. Upon receipt, this signal propagates directly to the RT 1553 Status Word. | | | | | | | | | | | | | | | |
| 24 MHz | CI | -- | 74 | T9 | 24 MHz Clock. The 24MHz input clock requires a 50% \pm 5% duty cycle with an accuracy of \pm 0.01%. See appendix 2 on UT54ACTS220 Clock Generator. | | | | | | | | | | | | | | | |
| $\overline{\text{MRST}}$ | TUI | AL | 73 | D15 | Master Reset. This input pin resets the internal encoders, decoders, all registers, and associated logic. | | | | | | | | | | | | | | | |
| MSEL(1) | TI | -- | 72 | B13 | Mode Select 1. This pin is the most significant bit for the mode select. For proper mode selection, see below: <table style="margin-left: auto; margin-right: auto;"> <tr> <td>MSEL(1)</td> <td>MSEL(0)</td> <td>Mode of Operation</td> </tr> <tr> <td>0</td> <td>0</td> <td>Bus Controller = SBC</td> </tr> <tr> <td>0</td> <td>1</td> <td>Remote Terminal = SRT</td> </tr> <tr> <td>1</td> <td>0</td> <td>Monitor Terminal = SMT</td> </tr> <tr> <td>1</td> <td>1</td> <td>SMT/SRT</td> </tr> </table> | MSEL(1) | MSEL(0) | Mode of Operation | 0 | 0 | Bus Controller = SBC | 0 | 1 | Remote Terminal = SRT | 1 | 0 | Monitor Terminal = SMT | 1 | 1 | SMT/SRT |
| MSEL(1) | MSEL(0) | Mode of Operation | | | | | | | | | | | | | | | | | | |
| 0 | 0 | Bus Controller = SBC | | | | | | | | | | | | | | | | | | |
| 0 | 1 | Remote Terminal = SRT | | | | | | | | | | | | | | | | | | |
| 1 | 0 | Monitor Terminal = SMT | | | | | | | | | | | | | | | | | | |
| 1 | 1 | SMT/SRT | | | | | | | | | | | | | | | | | | |
| MSEL(0) | TI | -- | 71 | A12 | Mode Select 0. This pin is the least significant bit for the mode select. (See MSEL1 for proper logic states.) | | | | | | | | | | | | | | | |

Note:

1. This output will drive low and three-state only.

| Name | Type | Active | Pin Number | | Description |
|--------------------------|------|--------|------------|-----|---|
| | | | FP | PGA | |
| TCLK | TI | -- | 68 | W8 | Timer Clock. The internal timer is a 16-bit counter with a 64 μ s resolution when using the 24MHz input clock. For different applications, the user may input a clock (0-6MHz) to establish the timer resolution. (Duty Cycle = 50% \pm 10%). |
| A/ \bar{B} STD | TUI | -- | 70 | C16 | Military Standard A or B. This pin defines whether the S μ MMIT LX/DX will be used in a MIL-STD-1553A or 1553B mode of operation. |
| $\overline{\text{LOCK}}$ | TUI | AL | 69 | T13 | Lock. This pin, when set active, prevents software changes to both the RT address, A/ \bar{B} STD, and mode select. |

Note:

1. Open drain outputs; high impedance and active low.

12.1.8 Status Signals

| Name | Type | Active | Pin Number | | Description |
|------------------------------|-----------------|--------|------------|-----|--|
| | | | FP | PGA | |
| $\overline{\text{TERACT}}$ | TO ² | AL | 63 | U16 | Terminal Active. This output pin indicates that the terminal is actively processing a 1553 command. |
| $\overline{\text{MSG_INT}}$ | OD ¹ | AL | 65 | D9 | Message Interrupt. This pin is active for three clock cycles (i.e., 125ns pulse) upon the occurrence of interrupt events which are enabled. |
| $\overline{\text{YF_INT}}$ | OD ¹ | AL | 66 | C12 | You Failed Interrupt. This pin is active for three clock cycles (i.e., 125ns pulse) upon the occurrence of interrupt events which are enabled. |
| $\overline{\text{READY}}$ | TO ² | AL | 64 | T15 | Ready. This signal indicates the S μ MMIT has completed a reset, an auto-initialization, or a BIT. After assertion of the READY signal initialization of the S μ MMIT for operation can begin. |

Note:

1. This output will drive low and three-state only.
2. These pins are driven low while $\overline{\text{MRST}}$ is low and 24MHz is active.

12.1.9 Power/Ground

The following shows the package location of all power and ground pins associated with the S μ MMIT LXE\DXE.

| Pin Number | Pin Number | | Description |
|------------------------------|--------------------------------|------------------------------|--|
| | FP | PGA | |
| V _{DD} | 9, 60, 62, 76, 99, 100 | C4, U4, B1, D7, T5, W10 | +5 Volt Logic Power ($\pm 10\%$) |
| V _{CC} | 30, 35, 36, 39, 40, 45 | D19, T19, C24, U24 | LXE: +5 Volt Transceiver Power (+10%, -5%) Recommended de-coupling capacitors: 4.7 μ F and .1 μ F DXE: +5 Volt Transceiver Power ($\pm 10\%$) Recommended de-coupling capacitors; 47 μ F and .1 μ F |
| V _{EE} ¹ | 27, 28, 47, 48 | T21, T23, D21, D23 (LX only) | -12 or -15 Volt Transceiver Power ($\pm 5\%$) Recommended de-coupling capacitors: 4.7 μ F and .1 μ F |
| V _{SS} | 5, 10, 61, 67, 77, 98 | C8, U8, D5, D11, T11, V1 | Digital Ground |
| GND | 29, 31, 34, 37, 38, 41, 44, 46 | T17, U20, W24, D17, C20, A24 | Transceiver Ground |

Note:

1. The V_{EE} pins are not connected in the 5-Volt only S μ MMIT LXE/DXE.

13.0 S μ MMIT XTE PIN IDENTIFICATION AND DESCRIPTION

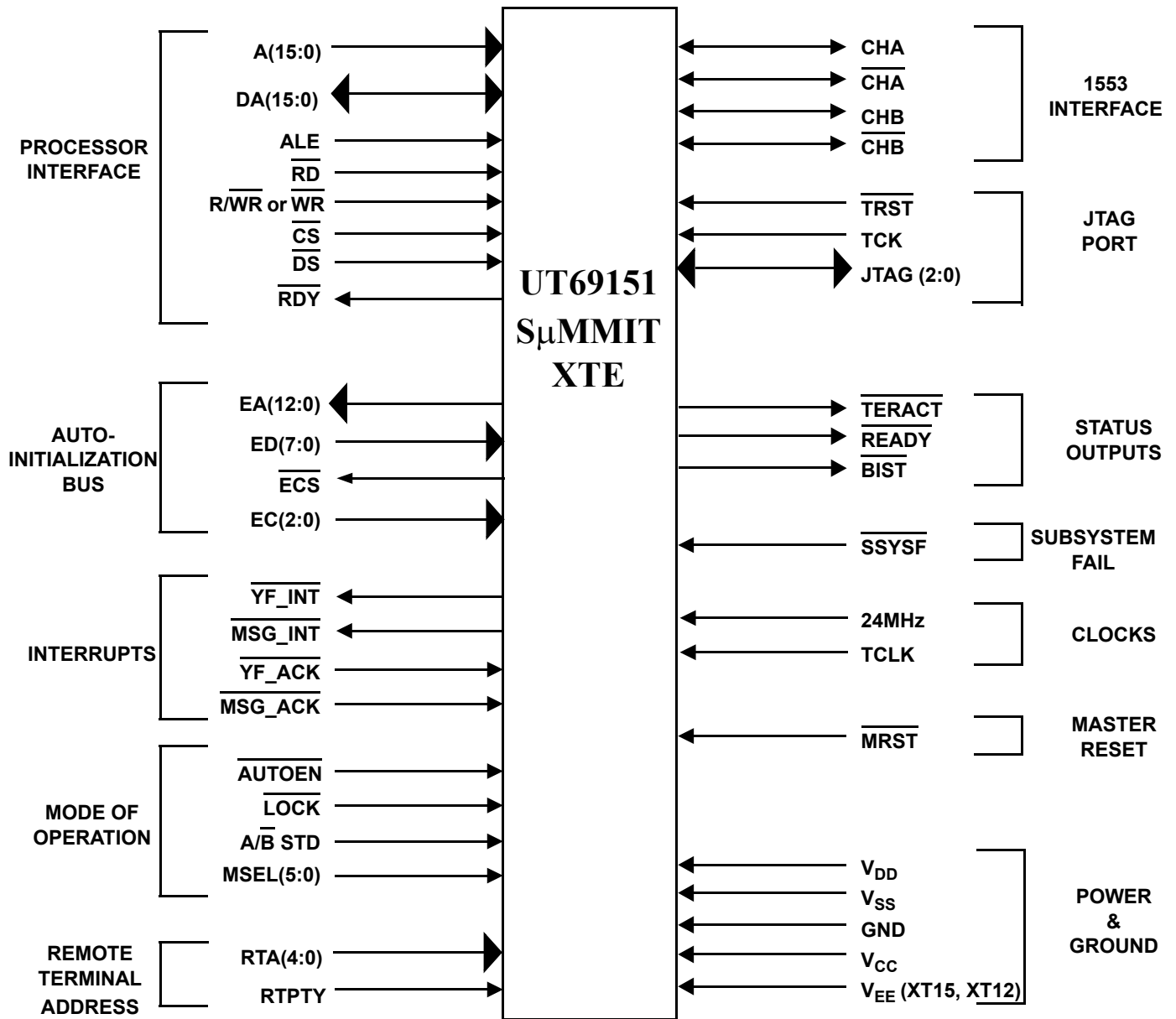

Figure 32. S μ MMIT XTE Functional Pin Diagram

13.1 SμMMIT XTE Functional Pin Description

Legend for TYPE and ACTIVE fields¹:

TO = TTL output
 TTB = Three-state TTL bidirectional
 CI = CMOS input
 TUI = TTL input (internally pulled high)
 AH = Active high
 AL = Active low
 TI = TTL input
 OD = Open drain
 TTO = Three-state TTL output
 PGA = Pingrid Array
 FP = Flatpack
 DIO = Differential input/output

Note:

1. All pins described as TTL use CMOS transistors that are designed compatibility with TTL devices.

13.1.1 Data Bus DA (15:0)

| Bit Number | Type | Active | Pin Number | | Description |
|------------|------|--------|------------|-----|---|
| | | | FP | PGA | |
| 15 | TTB | -- | 17 | N11 | Bit 15 (MSB) of the bidirectional Data bus. |
| 14 | TTB | -- | 18 | L10 | Bit 14 of the bidirectional Data bus. |
| 13 | TTB | -- | 19 | M11 | Bit 13 of the bidirectional Data bus. |
| 12 | TTB | -- | 20 | L11 | Bit 12 of the bidirectional Data bus. |
| 11 | TTB | -- | 21 | N12 | Bit 11 of the bidirectional Data bus. |
| 10 | TTB | -- | 22 | M12 | Bit 10 of the bidirectional Data bus. |
| 9 | TTB | -- | 23 | L12 | Bit 9 of the bidirectional Data bus. |
| 8 | TTB | -- | 24 | L13 | Bit 8 of the bidirectional Data bus. |
| 7 | TTB | -- | 25 | M13 | Bit 7 of the bidirectional Data bus. |
| 6 | TTB | -- | 26 | L14 | Bit 6 of the bidirectional Data bus. |
| 5 | TTB | -- | 28 | K11 | Bit 5 of the bidirectional Data bus. |
| 4 | TTB | -- | 29 | K13 | Bit 4 of the bidirectional Data bus. |
| 3 | TTB | -- | 30 | K12 | Bit 3 of the bidirectional Data bus. |
| 2 | TTB | -- | 31 | J11 | Bit 2 of the bidirectional Data bus. |
| 1 | TTB | -- | 32 | J12 | Bit 1 of the bidirectional Data bus. |
| 0 | TTB | -- | 33 | J13 | Bit 0 (LSB) of the bidirectional Data bus. |

13.1.2 Address Bus A(15:0)

| Bit Number | Type | Active | Pin Number | | Description |
|------------|------|--------|------------|-----|----------------------------------|
| | | | FP | PGA | |
| 15 | TI | -- | 38 | J14 | Bit 15 (MSB) of the Address bus. |
| 14 | TI | -- | 39 | H11 | Bit 14 of the Address bus. |
| 13 | TI | -- | 40 | H12 | Bit 13 of the Address bus. |
| 12 | TI | -- | 41 | H13 | Bit 12 of the Address bus. |
| 11 | TI | -- | 42 | G11 | Bit 11 of the Address bus. |
| 10 | TI | -- | 43 | G12 | Bit 10 of the Address bus. |
| 9 | TI | -- | 45 | G13 | Bit 9 of the Address bus. |
| 8 | TI | -- | 46 | G14 | Bit 8 of the Address bus. |
| 7 | TI | -- | 47 | F11 | Bit 7 of the Address bus. |
| 6 | TI | -- | 48 | F12 | Bit 6 of the Address bus. |
| 5 | TI | -- | 49 | F13 | Bit 5 of the Address bus. |
| 4 | TI | -- | 50 | D13 | Bit 4 of the Address bus. |
| 3 | TI | -- | 51 | E13 | Bit 3 of the Address bus. |
| 2 | TI | -- | 52 | C13 | Bit 2 of the Address bus. |
| 1 | TI | -- | 54 | E14 | Bit 1 of the Address bus. |
| 0 | TI | -- | 55 | C14 | Bit 0 (LSB) of the Address bus. |

13.1.3 Auto-initialization Address Bus EA(12:0)

| Bit Number | Type | Active | Pin Number | | Description |
|------------|------|--------|------------|-----|--|
| | | | FP | PGA | |
| 12 | TO | -- | 85 | F9 | Bit 12 (MSB) of the auto-init Address bus. |
| 11 | TO | -- | 84 | F10 | Bit 11 of the auto-init Address bus. |
| 10 | TO | -- | 83 | G10 | Bit 10 of the auto-init Address bus. |
| 9 | TO | -- | 82 | C11 | Bit 9 of the auto-init Address bus. |
| 8 | TO | -- | 81 | G9 | Bit 8 of the auto-init Address bus. |
| 7 | TO | -- | 80 | E11 | Bit 7 of the auto-init Address bus. |
| 6 | TO | -- | 79 | E10 | Bit 6 of the auto-init Address bus. |
| 5 | TO | -- | 78 | E9 | Bit 5 of the auto-init Address bus. |
| 4 | TO | -- | 77 | G8 | Bit 4 of the auto-init Address bus. |
| 3 | TO | -- | 76 | H8 | Bit 3 of the auto-init Address bus. |
| 2 | TO | -- | 75 | J7 | Bit 2 of the auto-init Address bus. |
| 1 | TO | -- | 74 | J9 | Bit 1 of the auto-init Address bus. |
| 0 | TO | -- | 73 | J10 | Bit 0 (LSB) of the auto-init Address bus. |

13.1.4 Auto-initialization Data Bus ED(7:0)

| Bit Number | Type | Active | Pin Number | | Description |
|------------|------|--------|------------|-----|------------------------------------|
| | | | FP | PGA | |
| 7 | TUI | -- | 68 | K10 | Bit 7 (MSB) of the auto-init data. |
| 6 | TUI | -- | 67 | M7 | Bit 6 of the auto-init data. |
| 5 | TUI | -- | 66 | N3 | Bit 5 of the auto-init data. |
| 4 | TUI | -- | 65 | N8 | Bit 4 of the auto-init data. |
| 3 | TUI | -- | 64 | M8 | Bit 3 of the auto-init data. |
| 2 | TUI | -- | 63 | L8 | Bit 2 of the auto-init data. |
| 1 | TUI | -- | 62 | N9 | Bit 1 of the auto-init data. |
| 0 | TUI | -- | 61 | M9 | Bit 0 (LSB) of the auto-init data. |

13.1.5 Remote Terminal Address Inputs

| Name | Type | Active | Pin Number | | Description |
|-------|------|--------|------------|-----|---|
| | | | FP | PGA | |
| RTA4 | TUI | -- | 115 | E2 | Remote Terminal Address 4. This is the most significant bit for the RT address. |
| RTA3 | TUI | -- | 116 | G3 | Remote Terminal Address 3. This is bit 3 of the RT address. |
| RTA2 | TUI | -- | 117 | F3 | Remote Terminal Address 2. This is bit 2 of the RT address. |
| RTA1 | TUI | -- | 118 | G2 | Remote Terminal Address 1. This is bit 1 of the RT address. |
| RTA0 | TUI | -- | 119 | F2 | Remote Terminal Address 0. This input is the least significant bit of the RT address. |
| RTPTY | TUI | -- | 120 | G1 | Remote Terminal Parity. This is an odd parity input for the RT address. |

13.1.6 JTAG Testability Pins

| Name | Type | Active | Pin Number | | Description |
|--------------------------|------|--------|------------|-----|--|
| | | | FP | PGA | |
| NC | -- | -- | 59 | N10 | Formerly MMU TDOM; now no connect. |
| V _{SS} | -- | -- | 58 | L9 | Formerly MMU TDIM; now tied to V _{SS} . |
| V _{SS} | -- | -- | 57 | M10 | Formerly MMU TMSM; now tied to V _{SS} . |
| TDO | TTO | -- | 134 | K3 | S _μ MMIT TDO. This input performs the operation of Test Data Output as defined in IEEE Standard 1149.1. |
| TDI | TUI | -- | 135 | K2 | S _μ MMIT TDI. This input performs the operation of Test Data Input as defined in IEEE Standard 1149.1. |
| TMS | TUI | -- | 136 | J2 | S _μ MMIT TMS. This input performs the operation of Test Mode Select as defined in IEEE Standard 1149.1. |
| TCK | TI | -- | 137 | L2 | TCK. This input performs the operation of Test Clock as defined in IEEE Standard 1149.1. Can operate up to 1MHz. |
| $\overline{\text{TRST}}$ | TUI | AL | 133 | L3 | $\overline{\text{TRST}}$. This input provides the RESET to the TAP controller as defined in the IEEE Standard 1149.1. This non-inverting input buffer is optimized for driving TTL input levels. When not exercising JTAG, tie $\overline{\text{TRST}}$ to a logical 0. |

13.1.7 Biphase Inputs/Outputs

| Name | Type | Active | Pin Number | | Description |
|-------------------------|------|--------|------------|-----|---|
| | | | FP | PGA | |
| CHA | DIO | -- | 92 | B7 | Channel A (True). This is the Manchester-encoded true signal for Channel A. |
| $\overline{\text{CHA}}$ | DIO | -- | 93 | A7 | Channel A (Complement). This is the Manchester-encoded complement signal for Channel A. |
| CHB | DIO | -- | 102 | A3 | Channel B (True). This is the Manchester-encoded true signal for Channel B. |
| $\overline{\text{CHB}}$ | DIO | -- | 103 | A2 | Channel B (Complement). This is the Manchester-encoded complement signal for Channel B. |

13.1.8 Control Signals

| Name | Type | Active | Pin Number FP | PGA | Description | | | | | | | | | | | | | | | |
|--|---------|---------------------------|------------------|-----|--|---------|---------|-------------------|---|---|----------------|---|---|-----------------|---|---|---------|---|---|---------------------------|
| \overline{CS} | TI | AL | 14 | A10 | Chip Select. This pin selects the S μ MMIT XTE's internal memory and registers. | | | | | | | | | | | | | | | |
| \overline{DS} | TI | AL | 12 | A12 | Data Strobe. During a write cycle, assert \overline{DS} to indicate that data is valid on the data bus. During a read cycle assert \overline{DS} to signal the S μ MMIT XTE to drive the data bus. | | | | | | | | | | | | | | | |
| \overline{RD} | TI | AL | 10 | K8 | Read Strobe. During a read cycle, assert \overline{RD} to signal the S μ MMIT XTE to drive the data bus. | | | | | | | | | | | | | | | |
| R/ \overline{WR} or \overline{WR} | TI | -- | 11 | K7 | Read/Write or Write Strobe. During a write cycle assert \overline{WR} to signal the S μ MMIT XTE that data is valid on the data bus. R/ \overline{WR} indicates the direction of data flow with respect to the S μ MMIT XTE. R/ \overline{WR} high indicates the S μ MMIT XTE will drive the data bus. R/ \overline{WR} low indicates an outside source will drive the data bus. | | | | | | | | | | | | | | | |
| MSEL(5) | TUI | -- | 124 | D12 | Mode Select 5. A logical zero enables the S μ MMIT XTE's 16-bit interface. A logical one enables the 8-bit interface. Latched on the rising edge of \overline{MRST} . | | | | | | | | | | | | | | | |
| MSEL(4) | TUI | -- | 125 | B13 | Mode Select 4. A logical zero enables a pulsed interrupt output. A logical one enables a level interrupt output. Latched on the rising edge of \overline{MRST} . | | | | | | | | | | | | | | | |
| MSEL(3) | TUI | -- | 126 | C12 | Mode Select 3. A logical zero enables the S μ MMIT XTE's multiplexed address and data bus interface. A logical one enables the non-multiplexed interface. Latched on the rising edge of \overline{MRST} . | | | | | | | | | | | | | | | |
| MSEL(2) | TUI | -- | 127 | A11 | Mode Select 2. A logical zero selects control signals \overline{RD} , \overline{WR} , \overline{CS} , \overline{DS} , and \overline{RDY} . A logical one selects control signals R/ \overline{WR} , \overline{CS} , \overline{DS} , and \overline{RDY} . Latched on the rising edge of \overline{MRST} . | | | | | | | | | | | | | | | |
| MSEL(1) | TI | -- | 128 | J3 | Mode Select 1. This pin in conjunction with MSEL(0) selects the S μ MMIT XTE's mode of operation. Latched on the rising edge of \overline{MRST} . <table border="1" style="margin-left: auto; margin-right: auto;"> <thead> <tr> <th>MSEL(1)</th> <th>MSEL(0)</th> <th>Mode of Operation</th> </tr> </thead> <tbody> <tr> <td>0</td> <td>0</td> <td>Bus Controller</td> </tr> <tr> <td>0</td> <td>1</td> <td>Remote Terminal</td> </tr> <tr> <td>1</td> <td>0</td> <td>Monitor</td> </tr> <tr> <td>1</td> <td>1</td> <td>Remote Terminal & Monitor</td> </tr> </tbody> </table> | MSEL(1) | MSEL(0) | Mode of Operation | 0 | 0 | Bus Controller | 0 | 1 | Remote Terminal | 1 | 0 | Monitor | 1 | 1 | Remote Terminal & Monitor |
| MSEL(1) | MSEL(0) | Mode of Operation | | | | | | | | | | | | | | | | | | |
| 0 | 0 | Bus Controller | | | | | | | | | | | | | | | | | | |
| 0 | 1 | Remote Terminal | | | | | | | | | | | | | | | | | | |
| 1 | 0 | Monitor | | | | | | | | | | | | | | | | | | |
| 1 | 1 | Remote Terminal & Monitor | | | | | | | | | | | | | | | | | | |
| MSEL(0) | TI | -- | 129 | J1 | Mode Select 0. This pin in conjunction with MSEL(1) selects the S μ MMIT XTE's mode of operation. | | | | | | | | | | | | | | | |
| EC(2) | TUI | -- | 97 | B10 | Latched on the rising edge of \overline{MRST} this input sizes the auto-initialization cycle. | | | | | | | | | | | | | | | |
| EC(1) | TUI | -- | 98 | D11 | Latched on the rising edge of \overline{MRST} this input sizes the auto-initialization cycle. | | | | | | | | | | | | | | | |

| Name | Type | Active | Pin Number FP | PGA | Description |
|------------------------------|------|--------|------------------|-----|--|
| EC(0) | TUI | -- | 99 | B12 | Latched on the rising edge of $\overline{\text{MRST}}$ this input sizes the auto-initialization cycle. |
| 24 MHz | CI | -- | 7 | N7 | 24 MHz Clock. The 24MHz input clock requires a $50\% \pm 5\%$ duty cycle with an accuracy of $\pm 0.01\%$. |
| $\overline{\text{MRST}}$ | TUI | AL | 130 | J8 | Master Reset. This input pin resets the internal encoder, decoder, all registers, and associated logic. |
| ALE | TI | AH | 13 | E12 | Address Latch Enable. The falling edge of this strobe latches address information into the S μ MMIT XTE when operating with a multiplexed address and data bus. |
| TCLK | TI | -- | 138 | L7 | Timer Clock. The internal timer is a 16-bit counter with a 64 μ s resolution when using the 24MHz input clock. For applications requiring a different resolution, the user may input a clock from 0 to 6MHz to establish the timer resolution. (Duty cycle equals $50\% \pm 10\%$). |
| A/B STD | TUI | -- | 122 | H2 | A/B. Military Standard A or B. This pin defines whether the S μ MMIT XTE operates per MIL-STD-1553A or MIL-STD-1553B. Input is latched on the rising edge of $\overline{\text{MRST}}$. |
| $\overline{\text{LOCK}}$ | TUI | AL | 121 | H3 | Lock. A logical zero applied to this pin prevents software from changing the RT address, A/B STD, or mode of operation. Input is latched on the rising edge of $\overline{\text{MRST}}$. |
| $\overline{\text{AUTOEN}}$ | TUI | AL | 131 | M2 | Auto Enable. When active this pin enables the S μ MMIT XTE's auto-initialization function. Input is latched on the rising edge of $\overline{\text{MRST}}$. |
| $\overline{\text{YF_ACK}}$ | TUI | AL | 3 | H9 | You Failed Interrupt Acknowledge. Assertion of this input resets interrupt output $\overline{\text{YF_INT}}$ when operating in the level mode. |
| $\overline{\text{MSG_ACK}}$ | TUI | AL | 5 | K9 | Message Interrupt Acknowledge. Assertion of this input resets interrupt output $\overline{\text{MSG_INT}}$ when operating in the level mode. |
| $\overline{\text{SSYSF}}$ | TUI | AL | 113 | D1 | Subsystem Fail. Upon assertion, this signal propagates directly to the RT's 1553 Status Word. |

13.1.9 Status Signals

| Name | Type | Active | Pin Number | | Description |
|------------------------------|-----------------|--------|------------|-----|---|
| | | | FP | PGA | |
| $\overline{\text{YF_INT}}$ | OD ¹ | AL | 4 | M3 | You Failed Interrupt. This pin asserts upon the occurrence of interrupt events which are not masked. Either a level output or pulse output. |
| $\overline{\text{MSG_INT}}$ | OD ¹ | AL | 6 | L1 | Message Interrupt. This pin asserts upon the occurrence of interrupt events which are not masked. Either a level output or pulse output. |
| $\overline{\text{READY}}$ | TO ² | AL | 110 | D9 | $\overline{\text{READY}}$. Assertion of this output indicates the S μ MMIT XTE has completed initialization or BIT, and regular operation may begin. |
| $\overline{\text{ECS}}$ | TO | AL | 96 | B11 | Chip Select. Auto-initialization device select. |
| $\overline{\text{RDY}}$ | TTO | AL | 15 | H10 | Access Ready. Assertion of this output indicates that the host can complete the S μ MMIT XTE access. |
| $\overline{\text{TERACT}}$ | TO ² | AL | 111 | F7 | $\overline{\text{TERACT}}$. This output indicates that the terminal is actively processing a 1553 command. |
| $\overline{\text{BIST}}$ | TTO | AL | 114 | D10 | Built-In Test. Assertion of this output indicates the S μ MMIT XTE is performing an internal memory test. |

NOTE:

1. This output will drive low and three-state only.
2. These pins are driven high while $\overline{\text{MRST}}$ is low and 24MHZ is active.

13.1.10 Power/Ground

The following shows the package location of all power and ground pins associated with the S μ MMIT XTE.

| Pin Number | Pin Number | | Description |
|------------------------------|--|--|--|
| | FP | PGA | |
| V _{DD} | 2, 9, 16, 34, 37, 44, 60, 69, 72, 139 | A8, B3, B14, F1, F14, G7, K1, K14, N2, N13 | +5 Volt Logic Power ($\pm 10\%$) |
| V _{CC} | CHA: 87, 94 CHB: 101, 107 | CHA: C9, C10, E8 CHB: C1, D3, F8 | XT15 & XT12: +5 Volt Transceiver Power (+10%,-5%) Recommended de-coupling capacitors: 47 μ F (tantalum), .1 μ F (ceramic) and .01 μ F (ceramic) XT5: +5 Volt Transceiver Power ($\pm 10\%$) Recommended de-coupling capacitors: 47 μ F (tantalum), .1 μ F (ceramic) and .01 μ F (ceramic) |
| V _{EE} ¹ | CHA: 86, 91 CHB: 100, 104 | CHA: D7, D8 CHB: C2, D2 | XT15 & XT12: -12 or -15 Volt Transceiver Power ($\pm 5\%$) |
| V _{SS} | 1, 27, 35, 36, 53, 70, 71, 123, 132, 140 | A9, A13, B2, B8, D14, H1, H7, H14, M1, M14 | Digital Ground |
| GND | CHA: 88, 89, 90, 95 CHB: 105, 106, 108, 112 | CHA: B9, C7, C8, E7 CHB: B1, C3, E1, E3 | Transceiver Ground |

Note:

1. The V_{EE} pins are not connected in the 5-Volt only S μ MMIT XTE.

13.1.11 No Connects

| Pin Number | Pin Number | | Description |
|------------|----------------|-----|-------------|
| | FP | PGA | |
| NC | 8, 56, 59, 109 | N10 | No Connects |

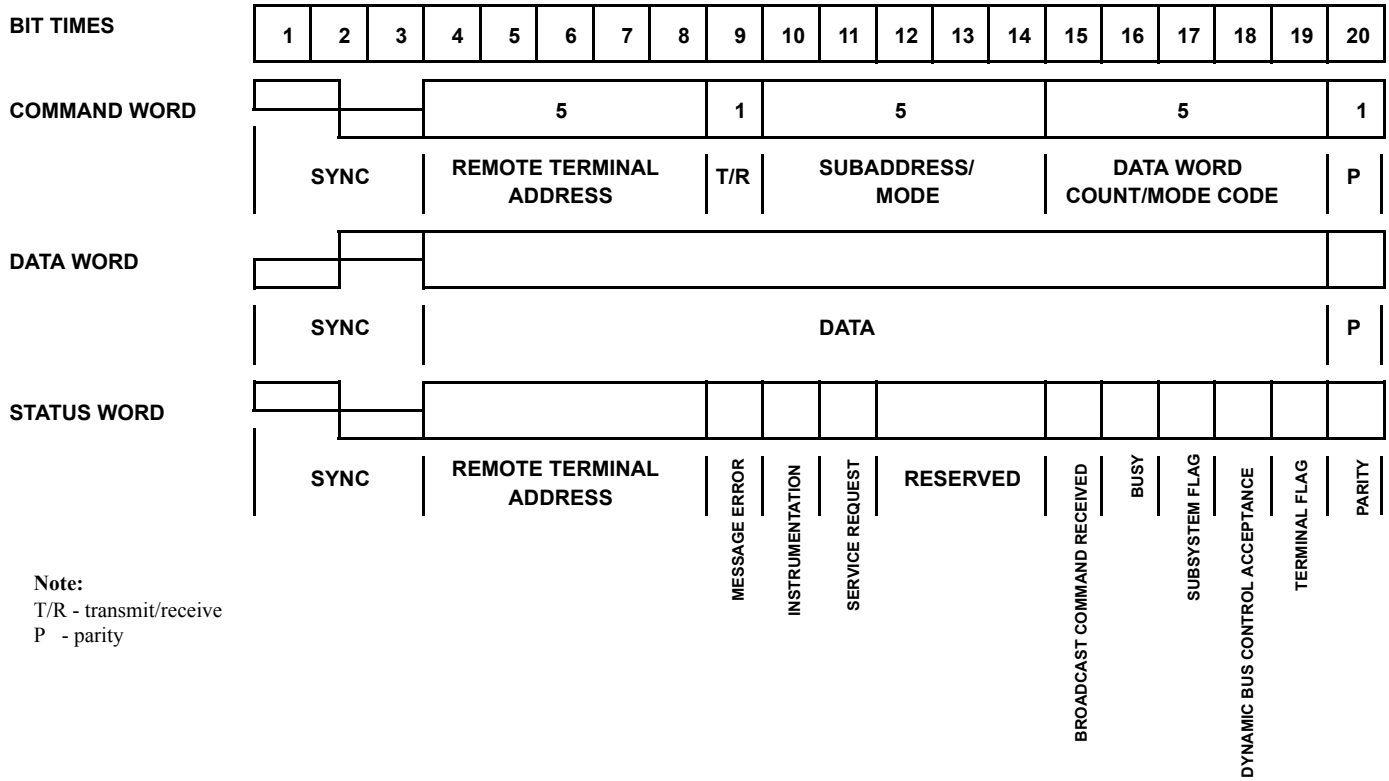

Figure 33. MIL-STD-1553B Word Formats

14.0 S μ MMIT E ABSOLUTE MAXIMUM RATINGS ¹

(Referenced to V_{SS})

| SYMBOL | PARAMETER | LIMIT | UNIT |
|---------------|--|----------------------|------|
| V_{DD} | DC supply voltage | -0.3 to 7.0 | V |
| $V_{I/O}$ | Voltage on any pin | -.3 to $V_{DD} + .3$ | V |
| T_{STG} | Storage temperature | -65 to +150 | °C |
| T_J | Maximum junction temperature | +150 | °C |
| I_I | DC input current | ± 10 | mA |
| T_S | Lead temperature (soldering, 5 seconds) | +300 | °C |
| Θ_{JC} | Thermal resistance, junction-to-case | 7 | °C/W |
| P_D | Maximum power dissipation | 2.5 | W |

Note:

1. Stresses outside the listed absolute maximum ratings may cause permanent damage to the device. This is a stress rating only, and functional operation of the device at these or any other conditions beyond limits indicated in the operational sections of this specification is not recommended. Exposure to absolute maximum rating conditions for extended periods may affect device reliability.

15.0 S μ MMIT E RECOMMENDED OPERATING CONDITIONS

| SYMBOL | PARAMETER | LIMIT | UNIT |
|----------|---------------------|---------------|------|
| V_{DD} | DC supply voltage | 4.5 to 5.5 | V |
| T_C | Temperature range | -55 to +125 | °C |
| V_{IN} | DC input voltage | 0 to V_{DD} | V |
| F_{IN} | Operating frequency | 24 \pm .01% | MHz |
| D_C | Duty cycle | 50 \pm 5 | % |

16.0 S μ MMIT E DC ELECTRICAL CHARACTERISTICS

($V_{DD} = 5.0V \pm 10\%$; $V_{SS} = 0V$ ¹; $-55^{\circ}C < T_C < +125^{\circ}C$)

| SYMBOL | PARAMETER | CONDITION | MIN | MAX | UNIT |
|-----------|--|--|---|-----------------|---------------------|
| V_{IL1} | Low-level input voltage | | | .8 | V |
| V_{IL2} | Low-level input voltage TCK input only | | | .7 | V |
| V_{IH} | High-level input voltage | | 2.2 | | V |
| V_{ILC} | Low-level input voltage ² | | | .3 V_{DD} | V |
| V_{IHC} | High-level input voltage ² | | .7 V_{DD} | | V |
| I_{IN} | Input leakage current TTL driven inputs Inputs with pull-up resistors Inputs with pull-up resistors | $V_{IN} = V_{DD}$ or V_{SS} $V_{IN} = V_{DD}$ $V_{IN} = V_{SS}$ | -10 -10 -167 | 10 10 -27 | μ A |
| V_{OL} | Low-level output voltage TTL output loads Single-drive buffer CMOS output loads | $I_{OL} = 4.0mA$ $I_{OL} = 1.0\mu A$ ⁷ | | .4 0.05 | V |
| V_{OH} | High-level output voltage TTL output loads Single-drive buffer CMOS output loads | $I_{OH} = -4.0mA$ $I_{OH} = -1.0\mu A$ ⁷ | 2.4 $V_{DD}-0.05$ | | V |
| I_{OZ} | Three-state output leakage current TTL output loads Single-drive buffer | $V_O = V_{DD}$ or V_{SS} | -10 | +10 | μ A |
| I_{OS} | Short-circuit output current ^{3,4} TTL output loads Single-drive buffer | $V_{DD} = 5.5V$, $V_O = 0V$ $V_{DD} = 5.5V$, $V_O = V_{DD}$ | -100 | +100 | mA |
| C_{IN} | Input capacitance ⁵ | $f = 1MHz @ 0V$ | | 15 | pF |
| C_{OUT} | Output capacitance ⁵ Single-drive buffer | $f = 1MHz @ 0V$ | | 15 | pF |
| C_{IO} | Bidirectional capacitance ⁵ | $f = 1MHz @ 0V$ | | 25 | pF |
| Q_{IDD} | Quiescent current ⁶ | $f = 0MHz$ - Non-RadHard, RadHard 100K RadHard 300K $f = 0MHz$ ($T_C = 25^{\circ}C$) | | 1 5 35 | mA mA μ A |
| S_{IDD} | Standby operating current | $f = 24MHz$ | $\overline{MRST} = V_{DD}$ $\overline{MRST} = V_{SS}$ ⁷ | 40 260 | mA |

Notes:

- Maximum allowable relative shift = 50mV.
- 24MHz input only.
- Supplied as a design limit but not guaranteed or tested.
- Not more than one output may be shorted at a time for maximum duration of one second.
- Capacitance measured for initial qualification or design changes which may affect the value.
- All inputs tied to V_{DD} .
- Guaranteed by characterization, not tested.

17.0 S μ MMIT LXE/DXE & S μ MMIT XTE ABSOLUTE MAXIMUM RATINGS ¹

(Referenced to V_{SS})

| SYMBOL | PARAMETER | LIMIT | UNIT |
|---------------|--|------------------------|----------------------------|
| V_{DD} | Logic supply voltage | -0.3 to 7.0 | V |
| P_D | Maximum power dissipation | 5 | W |
| V_{EE} | Transceiver supply voltage LXE, XTE15 & XTE12 | -22 | V |
| V_{CC} | Transceiver supply voltage DXE, XTE5 | -0.3 to 7.0 | V |
| V_{DR} | Input voltage range (receiver) LXE, XTE15 & XTE12 DXE, XTE5 | 42 10 | $V_{P,L-L}$ $V_{P,L-L}$ |
| $V_{I/O}$ | Logic voltage on any pin | -0.3 to $V_{DD} + 0.3$ | V |
| I_I | Logic input current | ± 10 | mA |
| I_O | Peak output current (transmitter) LXE, XTE15 & XTE12 DXE, XTE5 | 190 1000 | mA mA |
| T_{STG} | Storage temperature | -65 to +150 | $^{\circ}C$ |
| T_J | Maximum junction temperature LXE, XTE15 & XTE12 DXE, XTE5 | +150 +150 | $^{\circ}C$ |
| T_S | Lead temperature (soldering, 5 seconds) | +300 | $^{\circ}C$ |
| T_C | Operating temperature case | -55 to +125 | $^{\circ}C$ |
| Θ_{JC} | Thermal resistance, junction-to-case ² | 7 | $^{\circ}C/W$ |

Note:

1. Stress outside the listed absolute maximum rating may cause permanent damage to the device. This is a stress rating only, and functional operation of the device at these or any other conditions beyond limits indicated in the operational sections of this specification is not recommended. Exposure to absolute maximum rating conditions for extended periods may affect device reliability.
2. Mounting per MIL-STD-883, Method 1012.

18.0 S μ MMIT LXE/DXE & S μ MMIT XTE RECOMMENDED OPERATING CONDITIONS

| SYMBOL | PARAMETER | LIMIT | UNIT |
|-----------------|---|-----------------------------|------------------|
| V _{CC} | Transceiver supply voltage range LXE, XTE15 & XTE12 DXE, XTE5 | 4.75 to 5.5 4.5 to 5.5 | V |
| V _{DD} | Logic supply voltage | 4.5 to 5.5 | V |
| V _{EE} | Transceiver supply voltage range LXE, XTE15 & XTE12 | -12 or -15 ($\pm 5\%$) | V |
| V _{DR} | Receiver differential voltage LXE, XTE15 & XTE12 DXE, XTE5 | 40 8.0 | V _{P-P} |
| V _{IN} | Logic DC input voltage | 0 to V _{DD} | V |
| V _{IC} | Receiver common mode input voltage range LXE, XTE15 & XTE12 DXE, XTE5 | ± 10 ± 5.0 | V |
| I _O | Driver peak output current LXE, XTE15 & XTE12 DXE, XTE5 | 180 700 | mA |
| S _D | Serial data rate | 0 to 1 | MHz |
| D _C | Clock Duty cycle | 50 \pm 5 | % |
| T _C | Case operating temperature range | -55 to + 125 | $^{\circ}$ C |
| F _{IN} | Operating frequency | 24 \pm .01% | MHz |

19.0 S μ MMIT LXE/DXE & S μ MMIT XTE DC ELECTRICAL CHARACTERISTICS

19.1 S μ MMIT DXE & XTE DC Electrical Characteristics

$$V_{DD} = 5.0V \pm 10\%$$

$$V_{CC} = 5.0V \pm 10\% \text{ (DXE, XTE5)}, 5.0V +10\%, -5\% \text{ (LXE, XTE15 \& XTE12)}$$

$$V_{EE} = -12.0V \text{ or } -15.0V \pm 5\% \text{ (LXE, XTE15 \& XTE12)}$$

$$V_{SS} = 0V^1$$

$$GND = 0V^1$$

$$-55^\circ C < T_C < +125^\circ C$$

| SYMBOL | PARAMETER | CONDITION | MINIMUM | MAXIMUM | UNIT |
|------------------|--|--|------------------------------|-------------------|---------|
| V _{IL1} | Low-level input voltage | | | .8 | V |
| V _{IL2} | Low-level input voltage TCK input only | | | .7 | V |
| V _{IH} | High-level input voltage | | 2.2 | | V |
| V _{ILC} | Low-level input voltage ² | | | .3V _{DD} | V |
| V _{IHC} | High-level input voltage ² | | .7V _{DD} | | V |
| I _{IN} | Input leakage current TTL driven inputs Inputs with pull-up resistors Inputs with pull-up resistors | V _{IN} = V _{DD} or V _{SS} V _{IN} = V _{DD} V _{IN} = V _{SS} | -10 -10 -167 | +10 +10 -27 | μ A |
| V _{OL} | Low-level output voltage TTL output loads Single-drive buffer CMOS output loads | I _{OL} = 4.0mA I _{OL} = 1.0 μ A ³ | | .4 0.05 | V |
| V _{OH} | High-level output voltage TTL output loads Single-drive buffer CMOS output loads | I _{OH} = -4.0mA I _{OH} = -1.0 μ A ³ | 2.4 V _{DD} -0.05 | | V |
| I _{OZ} | Three-state output leakage current TTL output loads Single-drive buffer | V _O = V _{DD} or V _{SS} | -10 | +10 | μ A |
| I _{OS} | Short-circuit output current ^{3,4} TTL output loads Single-drive buffer | V _{DD} = 5.5V, V _O = 0V V _{DD} = 5.5V, V _O = V _{DD} | -100 | +100 | mA |
| C _{IN} | Input capacitance ⁵ | f = 1MHz @ 0V | | 45 | pF |
| C _{OUT} | Output capacitance ⁵ Single-drive buffer | f = 1MHz @ 0V | | 45 | pF |
| C _{IO} | Bidirectional capacitance ^{5,6} | f = 1MHz @ 0V | | 45 | pF |

Notes:

1. Maximum allowable relative shift = 50mV.
2. CMOS input only.
3. Guaranteed by design, but not tested.
4. Not more than one output may be shorted at a time for maximum duration of one second.
5. Capacitance measured for initial qualification or design changes which may affect the value.
6. For all pins except CHA, CH \bar{A} , CHB, and CH \bar{B} .

19.2 S μ MMIT LXE & XTE (15 & 12) DC Electrical Characteristics ^{1,2}

$$V_{DD} = 5.0V \pm 10\%$$

$$V_{SS} = 0V^1$$

$$V_{CC} = 5.0V +10\%, -5\%$$

$$GND = 0V^1$$

$$V_{EE} = -12.0V \text{ or } -15.0V \pm 5\%$$

$$-55^\circ\text{C} < TC < +125^\circ\text{C}$$

| SYMBOL | PARAMETER | CONDITION | MINIMUM | MAXIMUM | UNIT | |
|------------------|--------------------------------|---|---|---------|------|--|
| I _{CC} | V _{CC} supply current | V _{EE} = -12V V _{CC} = 5V | | | | |
| | | 0% duty cycle (non-transmitting) | | 140 | mA | |
| | | 50% duty cycle (f = 1MHz) ⁴ | | 140 | mA | |
| | | 100% duty cycle (f = 1MHz) ⁴ | | 140 | mA | |
| | | V _{EE} = -15V V _{CC} = 5V | | | | |
| | | 0% duty cycle (non-transmitting) | | 140 | mA | |
| I _{EE} | I _{EE} supply current | V _{EE} = -12V V _{CC} = 5V | | | | |
| | | 0% duty cycle (non-transmitting) | | 80 | mA | |
| | | 50% duty cycle (f = 1MHz) ⁴ | | 180 | mA | |
| | | 100% duty cycle (f = 1MHz) | | 270 | mA | |
| | | V _{EE} = -15V V _{CC} = 5V | | | | |
| | | 0% duty cycle (non-transmitting) | | 80 | mA | |
| Q _{IDD} | Quiescent current ³ | f = 0MHz XT | | 20 | mA | |
| | | f = 0MHz LX | | 1 | mA | |
| Q _{IDD} | Quiescent current ³ | f = 0MHz LX T _C = 25°C | | 35 | μA | |
| S _{IDD} | Standby operating current | f = 24MHz | $\overline{MRST} = V_{DD}$ | 80 | mA | |
| | | | $\overline{MRST} = V_{SS}$ ⁴ | 300 | mA | |

Notes: 1. Maximum allowable relative shift = 50mV.

2. As specified in test conditions.

3. All inputs tied to V_{DD}.

4. Guaranteed by characterization, not tested.

19.3 S μ MMIT DXE & XTE (5) DC Electrical Characteristics ^{1,2}

$$V_{DD} = 5.0V \pm 10\%$$

$$GND = 0V^1$$

$$V_{CC} = 5.0V \pm 10\%$$

$$-55^\circ\text{C} < TC < +125^\circ\text{C}$$

$$V_{SS} = 0V^1$$

| SYMBOL | PARAMETER | CONDITION | MINIMUM | MAXIMUM | UNIT |
|------------------|--------------------------------|---|---------|---------|------|
| I _{CC} | V _{CC} supply current | 0% duty cycle (non-transmitting) | | 55 | mA |
| | | 25% duty cycle (f = 1MHz) ³ | | 250 | mA |
| | | 50% duty cycle (f = 1MHz) ³ | | 410 | mA |
| | | 87.5% duty cycle (f = 1MHz) | | 650 | mA |
| Q _{IDD} | Quiescent current ² | f = 0MHz XT | | 20 | mA |
| | | f = 0MHz DX - Non-RadHard, RadHard 100K | | 1 | mA |
| | | f = 0MHz DX - RadHard 300K | | 5 | mA |
| Q _{IDD} | Quiescent current ² | f = 0MHz DX, T _C = 25°C | | 35 | μA |
| S _{IDD} | Standby operating current | f = 24MHz | | 40 | mA |

Notes: 1. Maximum allowable relative shift = 50mV.

2. All inputs tied to V_{DD}.

3. Guaranteed by characterization, not tested.

20.0 S μ MMIT E & S μ MMIT LXE/DXE AC ELECTRICAL CHARACTERISTICS

($f = 24\text{MHz} \pm .01\%$, Duty Cycle $50\% \pm 5\%$)

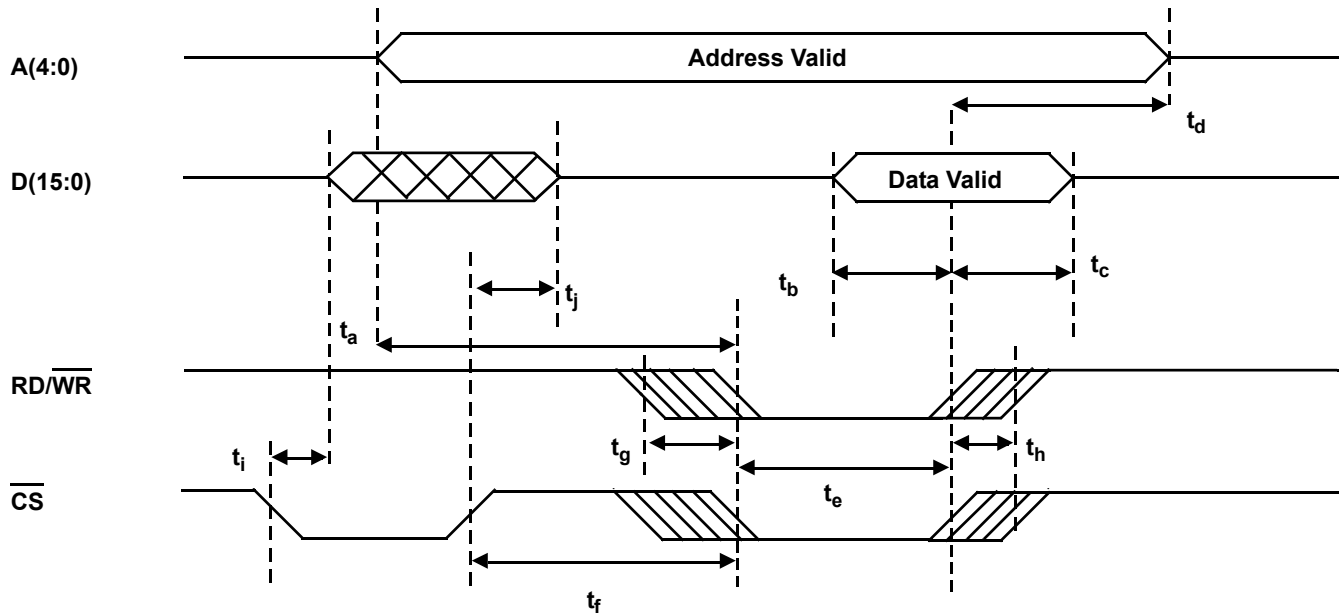

| SYMBOL | PARAMETER | MINIMUM | MAXIMUM | UNITS |
|--------|---|---------|---------|-------|
| t_a | Address setup time | 0 | -- | ns |
| t_b | Data setup time | 10 | -- | ns |
| t_c | Data hold time | 8 | -- | ns |
| t_d | Address hold time | 8 | -- | ns |
| t_e | $\overline{CS}\downarrow$ to $\overline{CS}\uparrow$ | 105 | -- | ns |
| t_f | Access delay ^{1,2} | 85 | -- | ns |
| t_g | RD/ \overline{WR} assertion to \overline{CS} assertion ³ | 0 | -- | ns |
| t_h | \overline{CS} negation to RD/ \overline{WR} negation ³ | 0 | -- | ns |
| t_i | \overline{CS} assertion to output enable | 0 | 40 | ns |
| t_j | \overline{CS} negation to output three-state ³ | 5 | 35 | ns |

Notes:

1. Read cycle followed by a Read cycle -minimum 45ns.
Read cycle followed by a Write cycle-minimum 45ns.
Write cycle followed by a Read cycle-minimum 85ns.
Write cycle followed by a Write cycle-minimum 85ns.
2. Minimum pulse width from latter rising edge of RD/ \overline{WR} or \overline{CS} to first falling edge.
3. Guaranteed by characterization, but not tested.

Figure 34. Register Write Timing

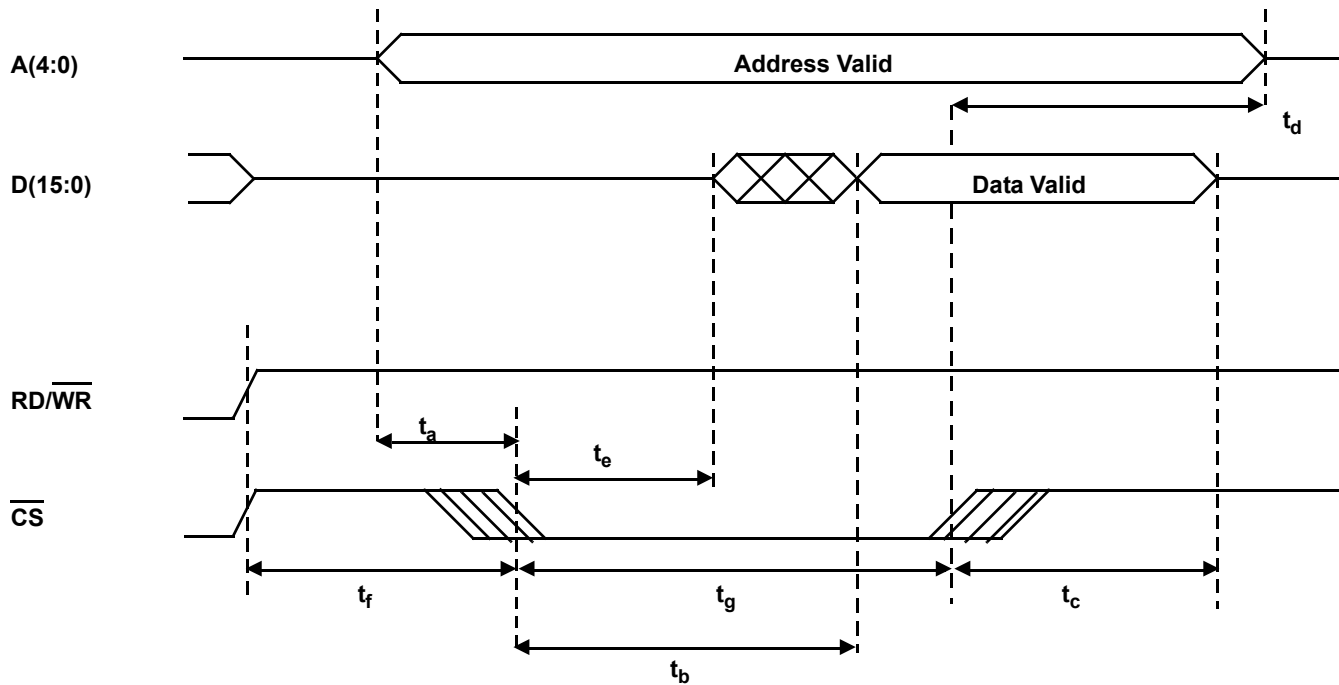

| SYMBOL | PARAMETER | MINIMUM | MAXIMUM | UNITS |
|--------|---|---------|---------|-------|
| t_a | Address setup time | 0 | -- | ns |
| t_b | \overline{CS} assertion to output enable data valid | -- | 95 | ns |
| t_c | \overline{CS} negation to output disabled ¹ | 5 | 35 | ns |
| t_d | Address hold time | 0 | -- | ns |
| t_e | \overline{CS} assertion to output enable data invalid | 0 | 40 | ns |
| t_f | Access delay ^{2,3} | 45 | -- | ns |
| t_g | $\overline{CS}\downarrow$ to $\overline{CS}\uparrow$ ¹ | 105 | -- | ns |

Notes:

1. Guaranteed by characterization, but not tested.
2. Minimum pulse width from latter rising edge of RD/WR or \overline{CS} to first falling edge.
3. Read cycle followed by a Read cycle - minimum 45ns.
 Read cycle followed by a Write cycle - minimum 45ns.
 Write cycle followed by a Read cycle - minimum 85ns.
 Write cycle followed by a Write cycle - minimum 85ns.

Figure 35. Register Read Timing

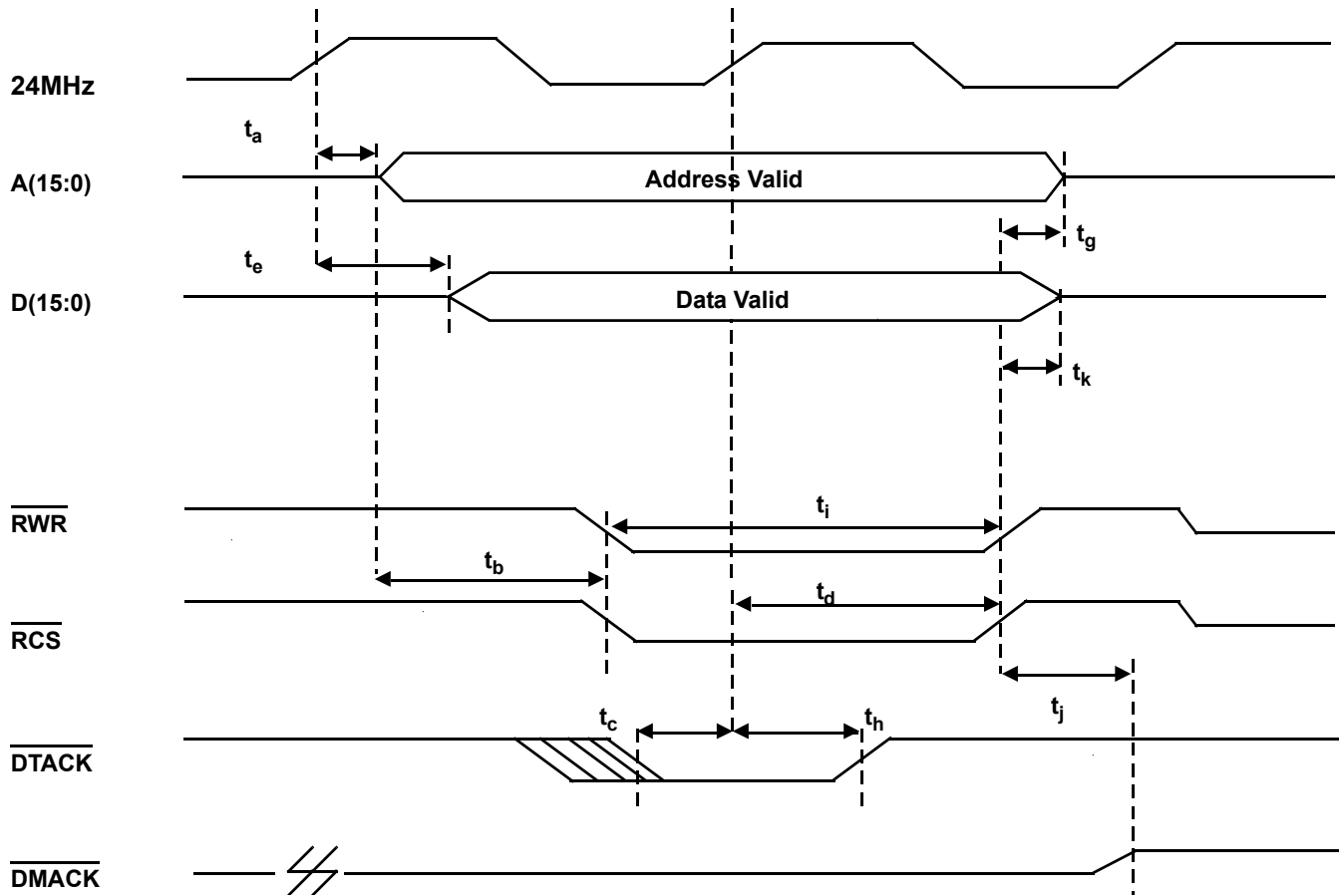

| SYMBOL | PARAMETER | MINIMUM | MAXIMUM | UNITS |
|--------|--|---------|---------|-------|
| t_a | Address propagation delay - RadHard | 0 | 18 | ns |
| | - non-RadHard | 0 | 21 | ns |
| t_b | Address valid to \overline{RCS} , \overline{RWR} assertion | 15 | 35 | ns |
| t_c | \overline{DTACK} setup time | 10 | -- | ns |
| t_d | \overline{RCS} and \overline{RWR} hold time ¹ | 20 | 50 | ns |
| t_e | Data propagation delay | 20 | 60 | ns |
| t_g | Address hold time | 10 | 30 | ns |
| t_h | \overline{DTACK} hold time | 10 | -- | ns |
| t_i | \overline{RWR} and \overline{RCS} pulse width (\overline{DTACK} tied to ground) | | | |
| | - RadHard | 34 | -- | ns |
| | - non-RadHard | 32 | -- | ns |
| t_j | \overline{RWR} and \overline{RCS} \uparrow to \overline{DMACK} \uparrow ² | 15 | 125 | ns |
| t_k | Data hold time ² | 10 | 40 | ns |

Notes:

1. Pulse width duration is measured with respect to the S μ MMIT recognizing \overline{DTACK} assertion.

2. Guaranteed by characterization, but not tested.

3. This timing diagram includes memory writes resulting from the S μ MMIT's auto-initialization sequence.

Figure 36. Memory Write Timing³

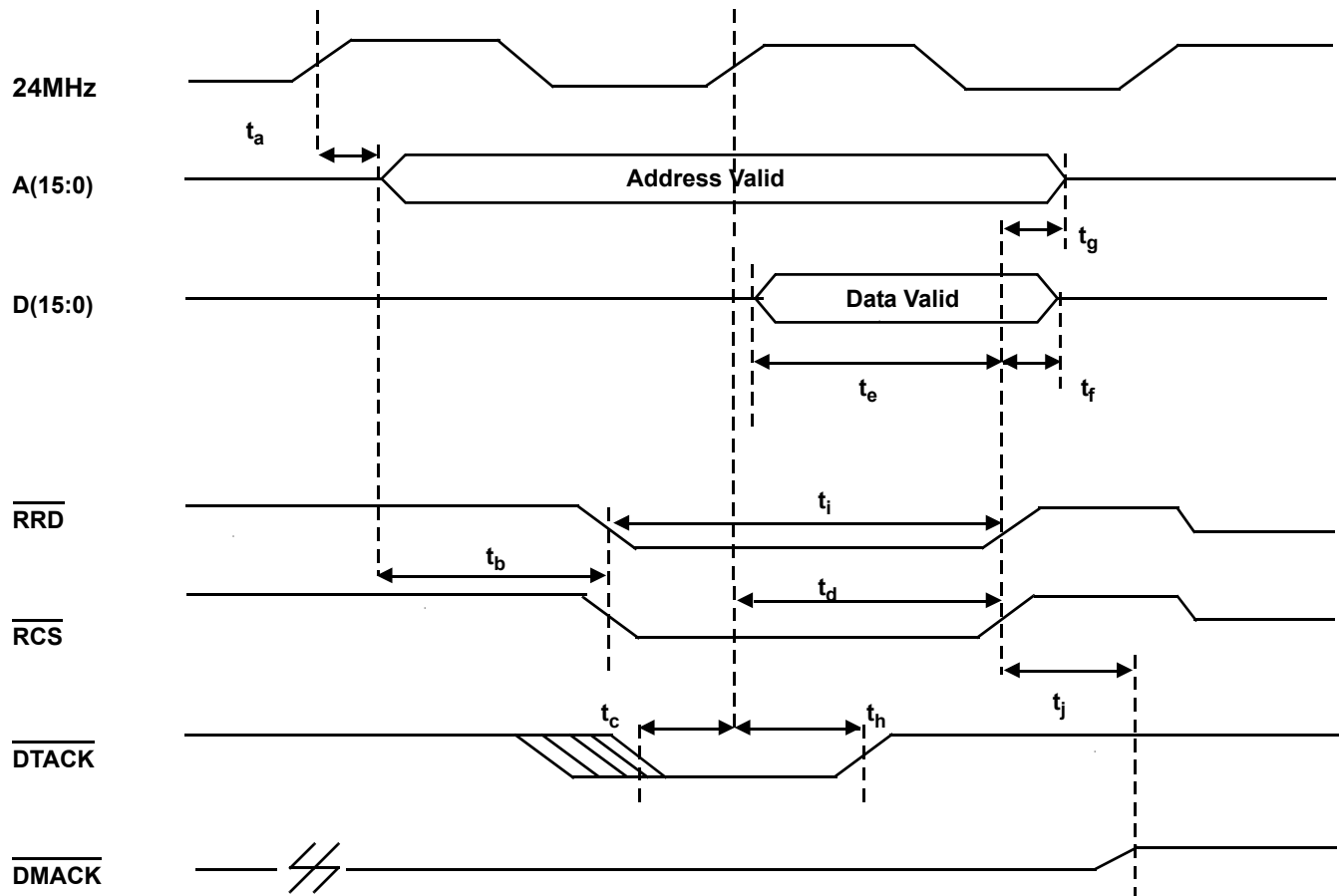

| SYMBOL | PARAMETER | MINIMUM | MAXIMUM | UNITS |
|--------|--|----------|----------|----------|
| t_a | Address propagation delay - RadHard - non-RadHard | 0 0 | 18 21 | ns |
| t_b | Address valid to \overline{RCS} , \overline{RRD} assertion | 15 | 35 | ns |
| t_c | \overline{DTACK} setup time | 10 | -- | ns |
| t_d | \overline{RCS} and \overline{RRD} hold time ¹ | 20 | 50 | ns |
| t_e | Data setup delay - RadHard - non-RadHard | 14 10 | -- -- | ns ns |
| t_f | Data hold delay - RadHard - non-RadHard | 0 2 | -- -- | ns ns |
| t_g | Address hold time | 10 | 30 | ns |
| t_h | \overline{DTACK} hold time | 10 | -- | ns |
| t_i | \overline{RRD} and \overline{RCS} pulse width (\overline{DTACK} tied to ground) - RadHard - non-RadHard | 34 32 | -- -- | ns ns |
| t_j | \overline{RRD} and \overline{RCS} \uparrow to \overline{DMACK} \uparrow ² | 15 | 45 | ns |

Notes:

1. Pulse width duration is measured with respect to the S μ MMIT's recognizing \overline{DTACK} assertion.
2. Guaranteed by characterization, but not tested.
3. This timing diagram includes memory writes resulting from the S μ MMIT's auto-initialization sequence.

Figure 37. Memory Read Timing³

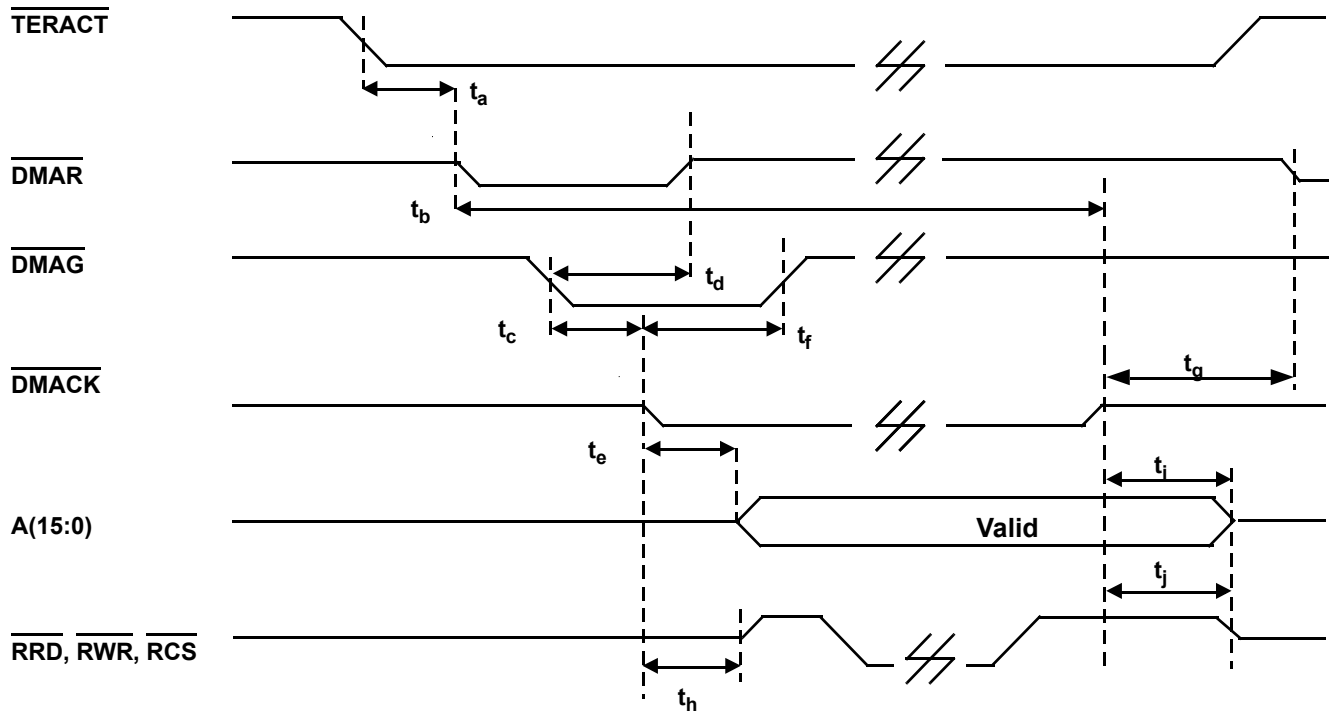

| SYMBOL | PARAMETER | MINIMUM | MAXIMUM | UNITS |
|--------|---|---------|---------|---------------|
| t_a | $\overline{\text{TERACT}}$ assertion to $\overline{\text{DMAR}}$ assertion ¹ | 5 | -- | μs |
| t_b | $\overline{\text{DMAR}}$ assertion to $\overline{\text{DMACK}}$ negation ¹ | -- | 16 | μs |
| | Bus Controller | -- | 7 | μs |
| | Remote Terminal | -- | 7 | μs |
| | Remote Terminal and Monitor | -- | 7 | μs |
| | Monitor | -- | 7 | μs |
| t_c | $\overline{\text{DMAG}}$ assertion to $\overline{\text{DMACK}}$ assertion - RadHard | 0 | 30 | ns |
| | - non-RadHard | 5 | 30 | ns |
| t_d | $\overline{\text{DMAG}}$ assertion to $\overline{\text{DMAR}}$ negation ¹ | 0 | 35 | ns |
| t_e | $\overline{\text{DMACK}}$ assertion to address bus active - RadHard | 0 | 5 | ns |
| | - non-RadHard | -5 | 5 | ns |
| t_f | $\overline{\text{DMACK}}$ assertion to $\overline{\text{DMAG}}$ negation | 10 | -- | ns |
| t_g | $\overline{\text{DMACK}}$ negation to $\overline{\text{DMAR}}$ assertion ¹ | 500 | -- | ns |
| t_h | $\overline{\text{DMACK}}$ assertion to RAM control active (negated) | | | |
| | - RadHard | 0 | 5 | ns |
| | - non-RadHard | -5 | 5 | ns |
| t_i | $\overline{\text{DMACK}}$ negation to $\text{A}(15:0)$ three-state ¹ | -- | 5 | ns |
| t_j | $\overline{\text{DMACK}}$ negation to RAM control disabled ¹ | -- | 5 | ns |

Note:

1. Guaranteed by characterization, but not tested.

Figure 38. DMA Timing

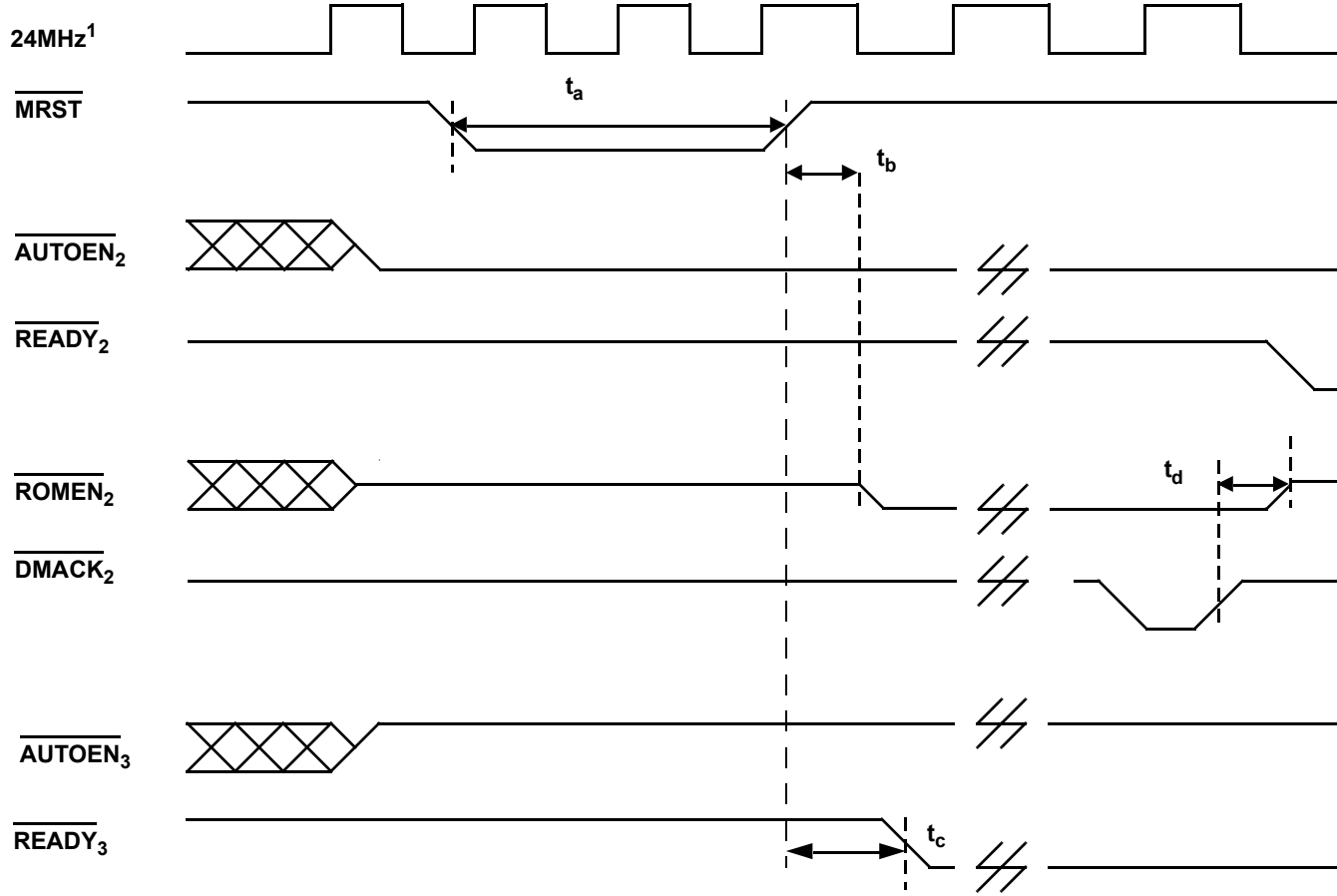

| SYMBOL | PARAMETER | MINIMUM | MAXIMUM | UNITS |
|--------|---|---------|---------|---------------|
| t_a | $\overline{\text{MRST}}$ pulse width ⁴ | 500 | -- | ns |
| t_b | $\overline{\text{MRST}}$ negation to $\overline{\text{ROMEN}}$ assertion ⁴ | -- | 5 | μs |
| t_c | $\overline{\text{MRST}}$ negation to $\overline{\text{READY}}$ assertion ⁴ | -- | 10 | μs |
| t_d | $\overline{\text{DMACK}}$ negation to $\overline{\text{ROMEN}}$ negation ⁴ | -- | 500 | ns |

- Note:**
1. μMMIT must receive at least 3 24MHz clock cycles before deassertion of $\overline{\text{MRST}}$.
 2. Power-up Master Reset Timing with Auto-initialization enabled.
 3. Power-up Master Reset Timing with Auto-initialization disabled.
 4. Guaranteed by characterization, but not tested.

Figure 39. Power-up Master Reset Timing

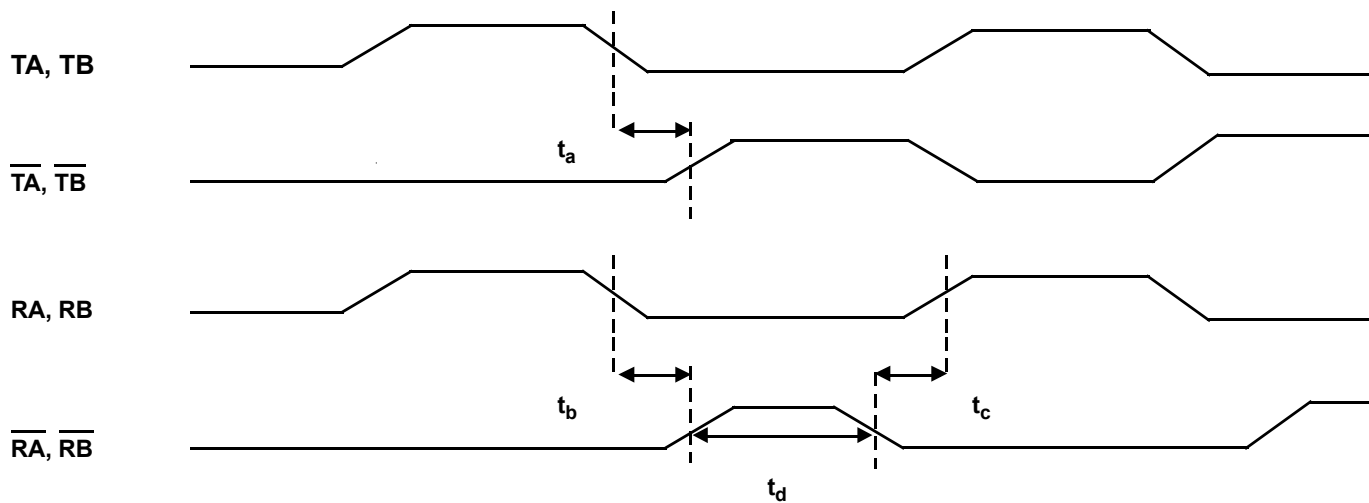

| SYMBOL | PARAMETER | MINIMUM | MAXIMUM | UNITS |
|--------|---|---------|---------|-------|
| t_a | Biphase output skew | -- | 10 | ns |
| t_b | Biphase input skew (low to high) ¹ | -- | 250 | ns |
| t_c | Biphase input skew (high to low) ¹ | -- | 250 | ns |
| t_d | Biphase input pulse width ¹ | 250 | -- | ns |

Note:

1. Guaranteed by characterization, but not tested.

Figure 40. BiPhase Timing (SμMMIT only)

21.0 S μ MMIT XTE AC ELECTRICAL CHARACTERISTICS

($f = 24\text{MHz} \pm 0.01\%$, Duty Cycle $50\% \pm 5\%$)

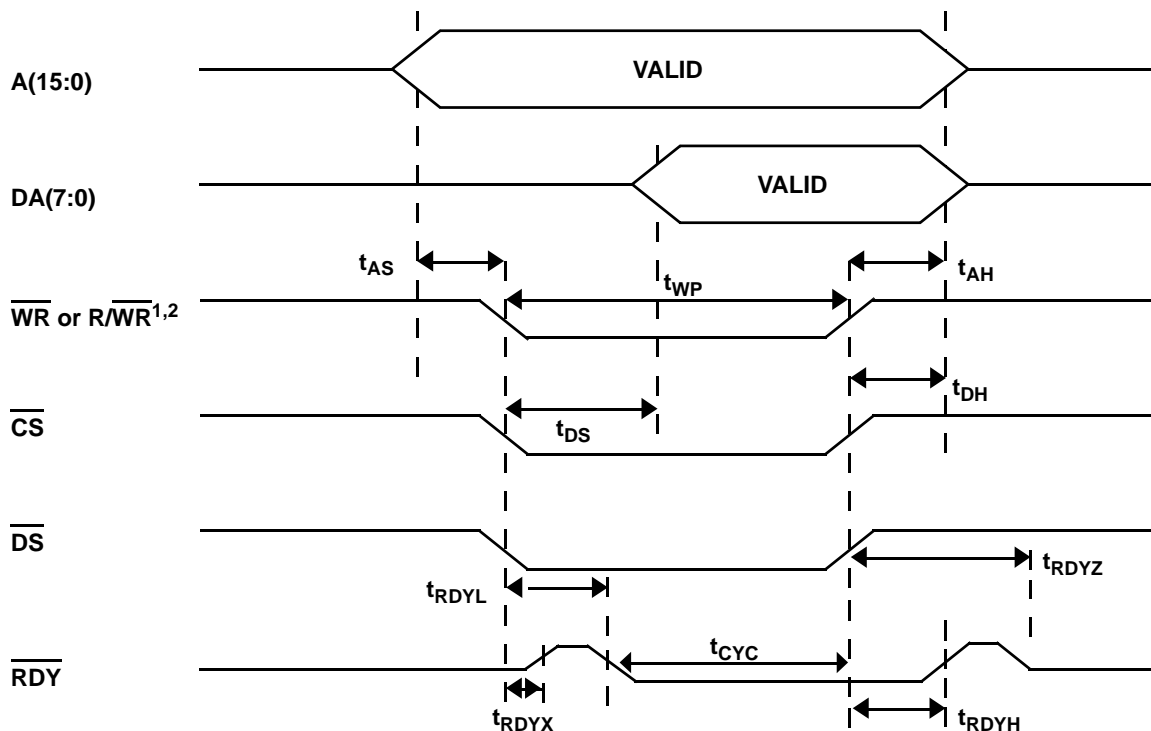

| SYMBOL | PARAMETER | MINIMUM | MAXIMUM | UNITS |
|------------|---|---------------------|-------------------|-------|
| t_{AS} | Address setup time ⁵ | 5 | -- | ns |
| t_{DS} | Data setup time ⁵ | -- | 20 | ns |
| t_{WP} | Write pulse width (non-contended) ⁵ | 230 ⁴ | -- | ns |
| t_{WP} | Write pulse width (contended) ⁵ | 2060 ^{3,4} | -- | ns |
| t_{AH} | Address hold time ⁵ | 0 | -- | ns |
| t_{DH} | Data hold time ⁵ | 0 | -- | ns |
| t_{RDYL} | $\overline{\text{RDY}}$ low time (non-contended) | -- | 245 | ns |
| t_{RDYL} | $\overline{\text{RDY}}$ low time (contended) ⁵ | -- | 2040 ³ | ns |
| t_{RDYH} | $\overline{\text{RDY}}$ high time ⁵ | 0 | 25 | ns |
| t_{RDYX} | $\overline{\text{RDY}}$ low Z ⁵ | 3 | -- | ns |
| t_{RDYZ} | $\overline{\text{RDY}}$ high Z | -- | 33 | ns |
| t_{CYC} | Minimum cycle time ⁵ | 20 | -- | ns |

Notes:

1. A cycle begins on the latter falling edge of $\overline{\text{CS}}$, $\overline{\text{DS}}$ and $\overline{\text{WR}}$ or $\overline{\text{R/W}}$.
2. A cycle ends on the rising edge of either $\overline{\text{CS}}$, $\overline{\text{DS}}$ and $\overline{\text{WR}}$ or $\overline{\text{R/W}}$.
3. Non-buffered mode of operation.
4. For applications not using $\overline{\text{RDY}}$ signal.
5. Guaranteed by design, not tested.

Figure 41. Non-Multiplexed Memory/Register Write (8-Bit)

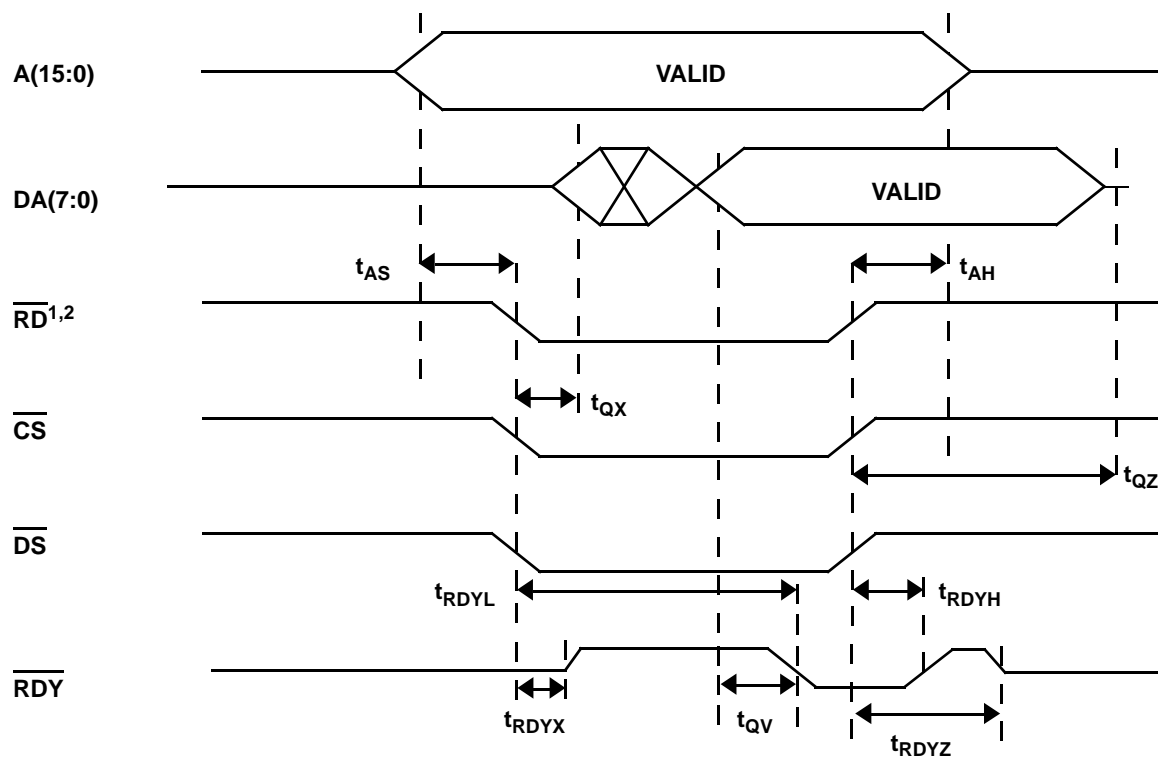

| SYMBOL | PARAMETER | MINIMUM | MAXIMUM | UNITS |
|------------|--|---------|-------------------|-------|
| t_{AS} | Address setup time ⁴ | 5 | -- | ns |
| t_{QX} | Data low Z ⁴ | 0 | 30 | ns |
| t_{AH} | Address hold time ⁴ | 0 | -- | ns |
| t_{QV} | Data valid ⁴ | 20 | -- | ns |
| t_{QZ} | Data high Z ⁴ | 0 | 32 | ns |
| t_{RDYL} | \overline{RDY} low time (non-contended) | | 245 | ns |
| t_{RDYL} | \overline{RDY} low time (contended) ⁴ | | 2040 ³ | ns |
| t_{RDYH} | \overline{RDY} high time ⁴ | 0 | 25 | ns |
| t_{RDYX} | \overline{RDY} low Z ⁴ | 3 | -- | ns |
| t_{RDYZ} | \overline{RDY} high | -- | 33 | ns |

Note:

1. A cycle begins on the latter falling edge of \overline{CS} , \overline{DS} and \overline{RD} .
2. A cycle ends on the rising edge of either \overline{CS} , \overline{DS} and \overline{RD} .
3. Non-buffered mode of operation.
4. Guaranteed by design, not tested.

Figure 42. Non-Multiplexed Memory/Register Read (8-Bit)

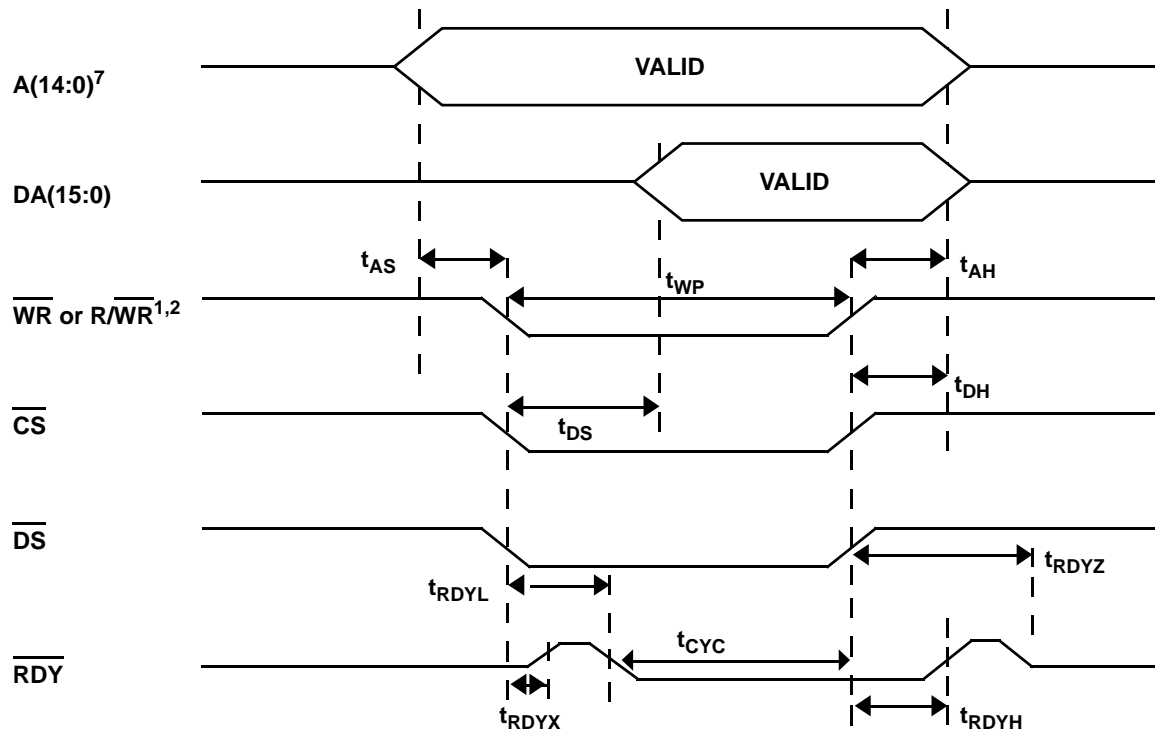

| SYMBOL | PARAMETER | MINIMUM | MAXIMUM | UNITS |
|------------|--|---------------------|-------------------|-------|
| t_{AS} | Address setup time ⁶ | 5 | -- | ns |
| t_{DS} | Data setup time ⁶ | -- | 20 | ns |
| t_{WP} | Write pulse width (non-contended) ⁵ | 230 ⁴ | -- | ns |
| t_{WP} | Write pulse width (contended) ⁵ | 2060 ^{3,4} | -- | ns |
| t_{AH} | Address hold time ⁶ | 0 | -- | ns |
| t_{DH} | Data hold time ⁶ | 0 | -- | ns |
| t_{RDYL} | \overline{RDY} low time (non-contended) | -- | 245 | ns |
| t_{RDYL} | \overline{RDY} low time (contended) ⁵ | -- | 2040 ³ | ns |
| t_{RDYH} | \overline{RDY} high time ⁶ | 0 | 25 | ns |
| t_{RDYX} | \overline{RDY} low Z ⁶ | 3 | -- | ns |
| t_{RDYZ} | \overline{RDY} high Z | -- | 33 | ns |
| t_{CYC} | Minimum cycle time ⁵ | 20 | -- | ns |

Notes:

1. A cycle begins on the latter falling edge of \overline{CS} , \overline{DS} and \overline{WR} or R/\overline{WR} .
2. A cycle ends on the rising edge of either \overline{CS} , \overline{DS} and \overline{WR} or R/\overline{WR} .
3. Non-buffered mode of operation.
4. For applications not using \overline{RDY} signal.
5. Guaranteed by design, not tested.
6. Guaranteed by device characterization, not tested.
7. A15 must be tied low.

Figure 43. Non-Multiplexed Memory/Register Write (16-Bit)

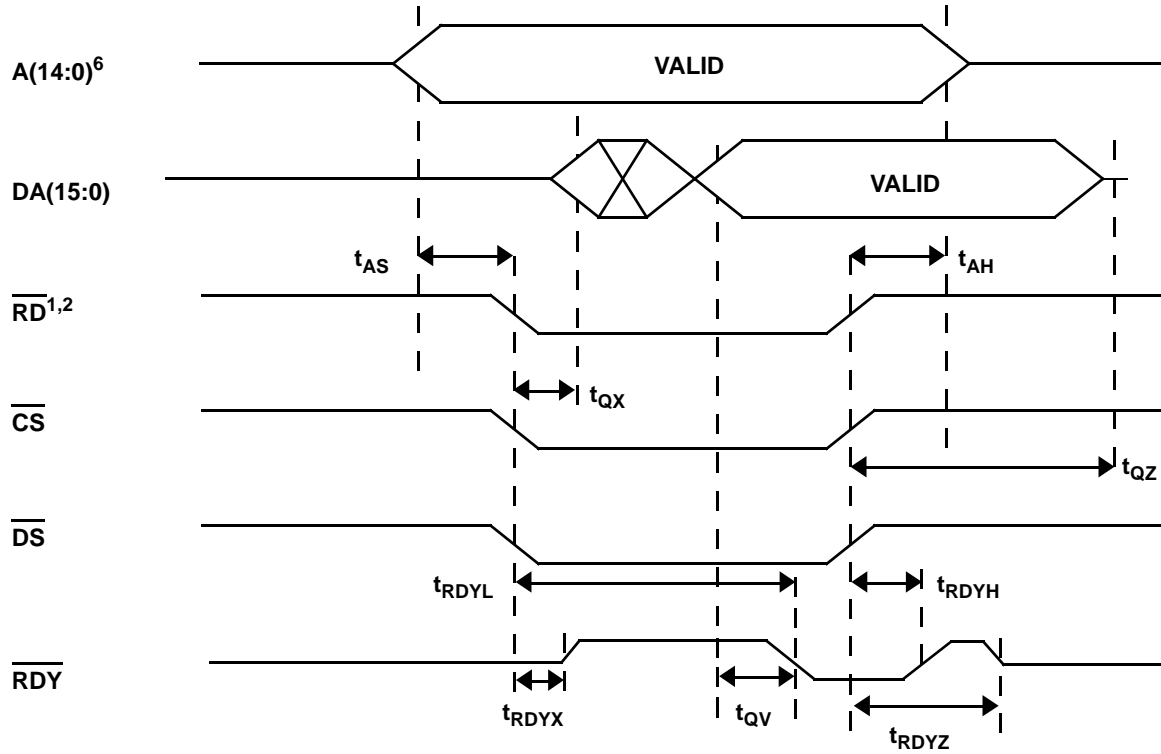

| SYMBOL | PARAMETER | MINIMUM | MAXIMUM | UNITS |
|------------|--|---------|-------------------|-------|
| t_{AS} | Address setup time ⁵ | 5 | -- | ns |
| t_{QX} | Data low Z ⁵ | 0 | 30 | ns |
| t_{AH} | Address hold time ⁵ | 0 | -- | ns |
| t_{QV} | Data valid ⁵ | 20 | -- | ns |
| t_{QZ} | Data high Z ⁵ | 0 | 32 | ns |
| t_{RDYL} | \overline{RDY} low time (non-contended) | -- | 245 | ns |
| t_{RDYL} | \overline{RDY} low time (contended) ⁴ | -- | 2040 ³ | ns |
| t_{RDYH} | \overline{RDY} high time ⁵ | 0 | 25 | ns |
| t_{RDYX} | \overline{RDY} low Z ⁵ | 3 | -- | ns |
| t_{RDYZ} | \overline{RDY} high Z | -- | 33 | ns |

Notes:

1. A cycle begins on the latter falling edge of \overline{CS} , \overline{DS} and \overline{RD} .
2. A cycle ends on the rising edge of either \overline{CS} , \overline{DS} and \overline{RD} .
3. Non-buffered mode of operation.
4. Guaranteed by design, not tested.
5. Guaranteed by device characterization, not tested.
6. A15 must be tied low.

Figure 44. Non-Multiplexed Memory/Register Read (16-Bit)

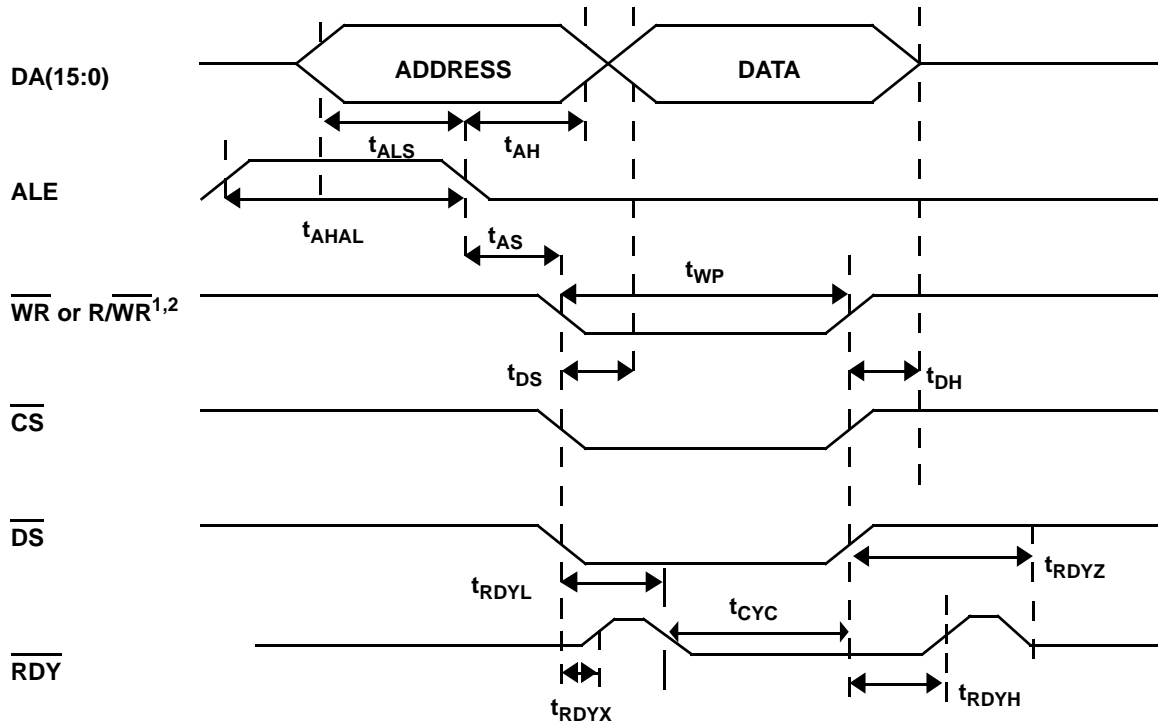

| SYMBOL | PARAMETER | MINIMUM | MAXIMUM | UNITS |
|------------|--|---------------------|-------------------|-------|
| t_{AS} | Address setup time ⁵ | 0 | -- | ns |
| t_{AHAL} | ALE pulse width ⁵ | 20 | -- | ns |
| t_{DS} | Data setup time ⁶ | -- | 0 | ns |
| t_{WP} | Write pulse width (non-contended) ⁵ | 230 ⁴ | -- | ns |
| t_{WP} | Write pulse width (contended) ⁵ | 2060 ^{3,4} | -- | ns |
| t_{AH} | Address hold time ⁶ | 5 | -- | ns |
| t_{DH} | Data hold time ⁶ | 0 | -- | ns |
| t_{RDYL} | \overline{RDY} low time (non-contended) ⁶ | -- | 245 | ns |
| t_{RDYL} | \overline{RDY} low time (contended) ⁵ | -- | 2040 ³ | ns |
| t_{RDYH} | \overline{RDY} high time ⁵ | 0 | 25 | ns |
| t_{RDYX} | \overline{RDY} low Z ⁵ | 3 | -- | ns |
| t_{RDYZ} | \overline{RDY} high Z ⁵ | -- | 33 | ns |
| t_{ALS} | Address latch setup time ⁶ | 5 | -- | ns |
| t_{CYC} | Minimum cycle time ⁵ | 20 | -- | ns |

Notes:

1. A cycle begins on the latter falling edge of \overline{CS} , \overline{DS} and \overline{WR} or $\overline{R/W}$.
2. A cycle ends on the rising edge of either \overline{CS} , \overline{DS} and \overline{WR} or $\overline{R/W}$.
3. Non-buffered mode of operation.
4. For applications not using \overline{RDY} signal.
5. Guaranteed by design, not tested.
6. Guaranteed by device characterization, not tested.

Figure 45. Multiplexed Memory/Register Write (8-Bit)

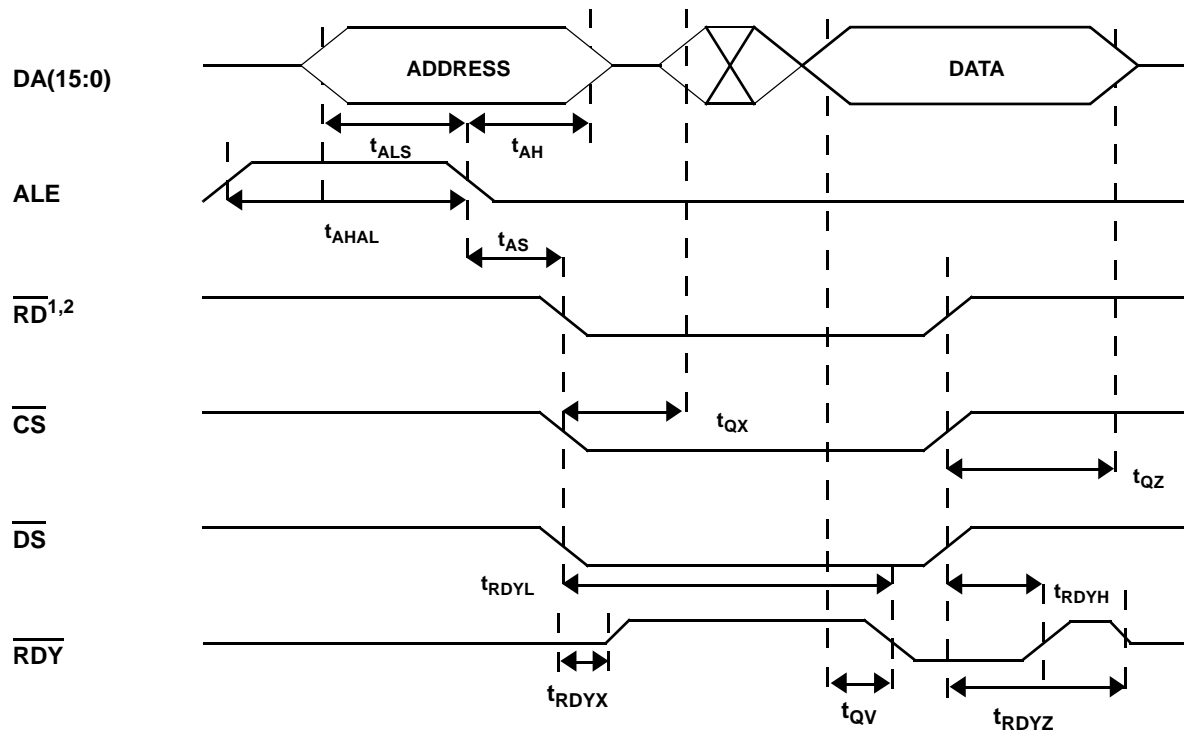

| SYMBOL | PARAMETER | MINIMUM | MAXIMUM | UNITS |
|------------|--|---------|-------------------|-------|
| t_{AS} | Address setup time ⁴ | 0 | -- | ns |
| t_{AHAL} | ALE pulse width ⁴ | 20 | -- | ns |
| t_{QX} | Data low Z ⁴ | 0 | 30 | ns |
| t_{AH} | Address hold time | 5 | -- | ns |
| t_{QV} | Data valid | 12 | -- | ns |
| t_{QZ} | Data high Z | 3 | 32 | ns |
| t_{RDYL} | \overline{RDY} low time (non-contended) ⁴ | -- | 245 | ns |
| t_{RDYL} | \overline{RDY} low time (contended) ⁴ | -- | 2040 ³ | ns |
| t_{RDYH} | \overline{RDY} high time ⁴ | 0 | 25 | ns |
| t_{RDYX} | \overline{RDY} low Z ⁴ | 3 | -- | ns |
| t_{RDYZ} | \overline{RDY} high Z ⁴ | -- | 33 | ns |
| t_{ALS} | Address latch setup time ⁴ | 5 | -- | ns |

Notes:

1. A cycle begins on the latter falling edge of \overline{CS} , \overline{DS} and \overline{RD} .
2. A cycle ends on the rising edge of either \overline{CS} , \overline{DS} and \overline{RD} .
3. Non-buffered mode of operation.
4. Guaranteed by design, not tested.

Figure 46. Multiplexed Memory/Register Read (8-Bit)

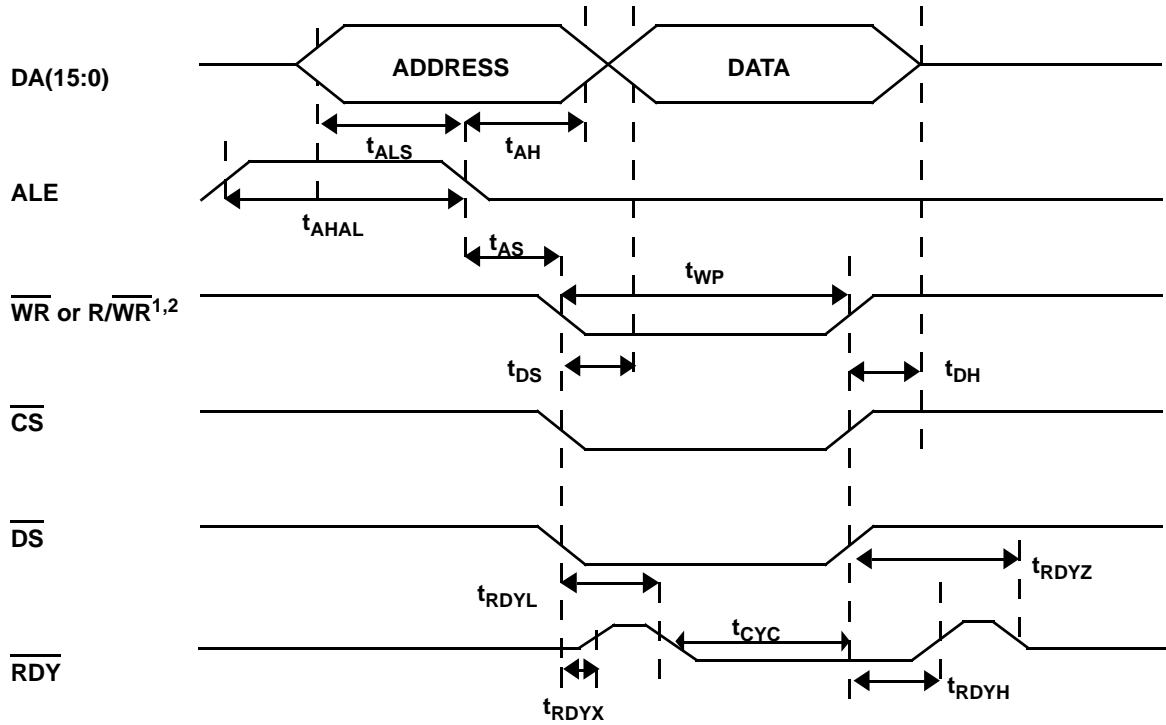

| SYMBOL | PARAMETER | MINIMUM | MAXIMUM | UNITS |
|------------|--|---------------------|-------------------|-------|
| t_{AS} | Address setup time ⁵ | 0 | -- | ns |
| t_{AHAL} | ALE pulse width ⁵ | 20 | -- | ns |
| t_{DS} | Data setup time ⁵ | -- | 20 | ns |
| t_{WP} | Write pulse width (non-contended) ⁵ | 230 ⁴ | -- | ns |
| t_{WP} | Write pulse width (contended) ⁵ | 2060 ^{3,4} | -- | ns |
| t_{AH} | Address hold time ⁵ | 5 | -- | ns |
| t_{DH} | Data hold time ⁵ | 5 | -- | ns |
| t_{RDYL} | \overline{RDY} low time (non-contended) ⁵ | -- | 245 | ns |
| t_{RDYL} | \overline{RDY} low time (contended) ⁵ | -- | 2040 ³ | ns |
| t_{RDYH} | \overline{RDY} high time ⁵ | 0 | 25 | ns |
| t_{RDYX} | \overline{RDY} low Z ⁵ | 3 | -- | ns |
| t_{RDYZ} | \overline{RDY} high Z ⁵ | -- | 33 | ns |
| t_{ALS} | Address latch setup time ⁵ | 5 | -- | ns |
| t_{CYC} | Minimum cycle time ⁵ | 20 | -- | ns |

Notes:

1. A cycle begins on the latter falling edge of \overline{CS} , \overline{DS} and \overline{WR} or $\overline{R/W}$
2. A cycle ends on the rising edge of either \overline{CS} , \overline{DS} and \overline{WR} or $\overline{R/W}$.
3. Non-buffered mode of operation.
4. For applications not using \overline{RDY} signal.
5. Guaranteed by design, not tested.

Figure 47. Multiplexed Memory/Register Write (16-Bit)

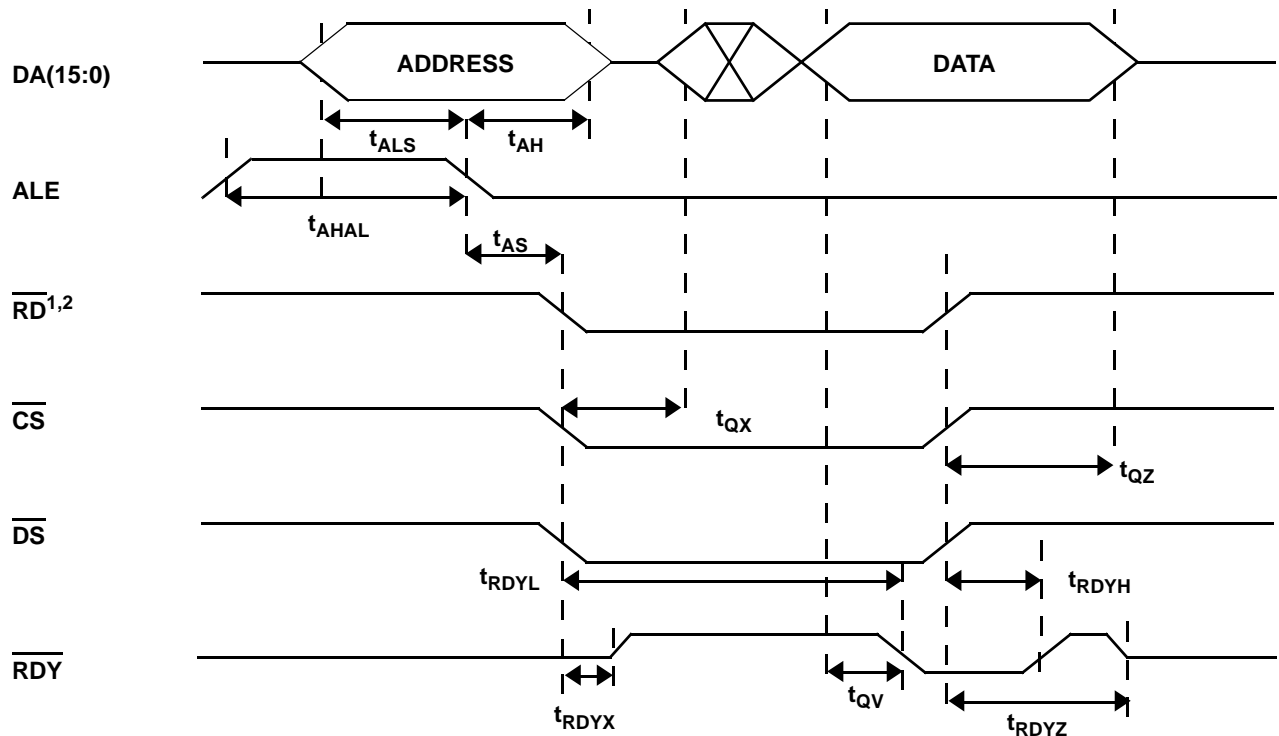

| SYMBOL | PARAMETER | MINIMUM | MAXIMUM | UNITS |
|------------|--|---------|-------------------|-------|
| t_{AS} | Address setup time ⁴ | 0 | -- | ns |
| t_{AHAL} | ALE pulse width ⁴ | 20 | -- | ns |
| t_{QX} | Data low Z ⁴ | 0 | 30 | ns |
| t_{AH} | Address hold time ⁴ | 5 | -- | ns |
| t_{QV} | Data valid ⁴ | 20 | -- | ns |
| t_{QZ} | Data high Z ⁴ | 3 | 32 | ns |
| t_{RDYL} | \overline{RDY} low time (non-contended) ⁴ | -- | 245 | ns |
| t_{RDYL} | \overline{RDY} low time (contended) ⁴ | -- | 2040 ³ | ns |
| t_{RDYH} | \overline{RDY} high time ⁴ | 0 | 25 | ns |
| t_{RDYX} | \overline{RDY} low Z ⁴ | 3 | -- | ns |
| t_{RDYZ} | \overline{RDY} high Z ⁴ | -- | 33 | ns |
| t_{ALS} | Address latch setup time ⁴ | 5 | -- | ns |

Notes:

1. A cycle begins on the latter falling edge of \overline{CS} , \overline{DS} and \overline{RD} .
2. A cycle ends on the rising edge of either \overline{CS} , \overline{DS} and \overline{RD} .
3. Non-buffered mode of operation.
4. Guaranteed by design, not tested.

Figure 48. Multiplexed Memory/Register Read (16-Bit)

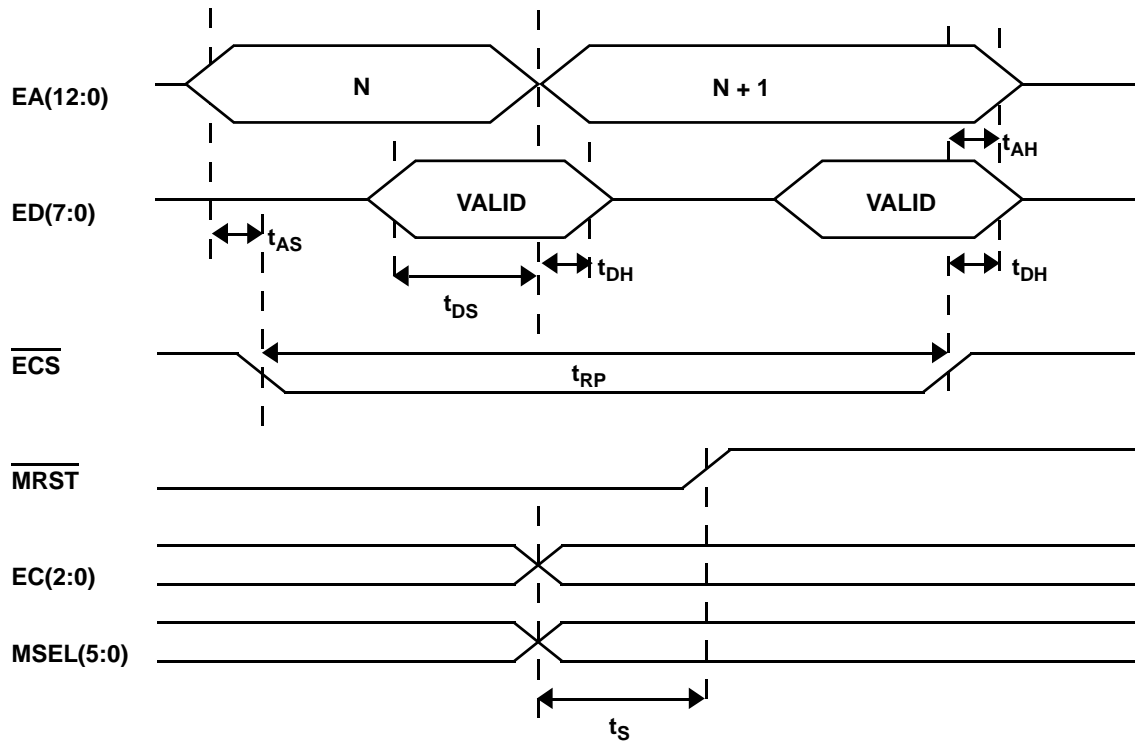

| SYMBOL | PARAMETER | MINIMUM | MAXIMUM | UNITS |
|----------|---------------------------------|---------|---------|-------|
| t_{AS} | Address setup time ¹ | 35 | -- | ns |
| t_{AH} | Address hold time ¹ | 35 | -- | ns |
| t_{DS} | Data setup time ¹ | 41 | -- | ns |
| t_{DH} | Data hold time ¹ | 5 | -- | ns |
| t_{RP} | Read pulse width ¹ | 160 | -- | ns |
| t_s | Setup time ¹ | 45 | -- | ns |

Notes:

1. Guaranteed by design, not tested.

Figure 49. Auto-Initialization Read Cycle

Address Bus
 A(15:0), A(14:0), DA(15:0),
 or DA(14:0)

Control Signals
 (DS, CS, RD, R/WR)

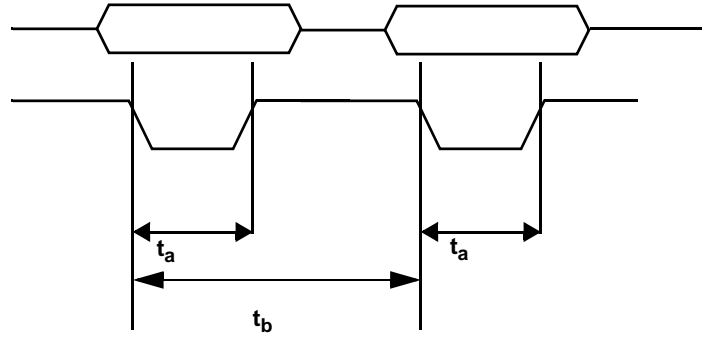

| SYMBOL | PARAMETER | MINIMUM | MAXIMUM | UNITS |
|--------|--|---------|---------|---------------|
| t_a | Maximum Register/Memory Time | -- | 16 | μS |
| | Bus Controller ¹ | -- | 7 | μS |
| | Remote Terminal ¹ | -- | 7 | μS |
| | Remote Terminal and Monitor ¹ | -- | 7 | μS |
| | Monitor ¹ | -- | 7 | μS |
| t_b | Delay Between Register or Memory ¹ Accesses (Read/Write) | 83 | -- | nS |

Notes:

1. Guaranteed by design, not tested.

Figure 50. Maximum Cycle Time

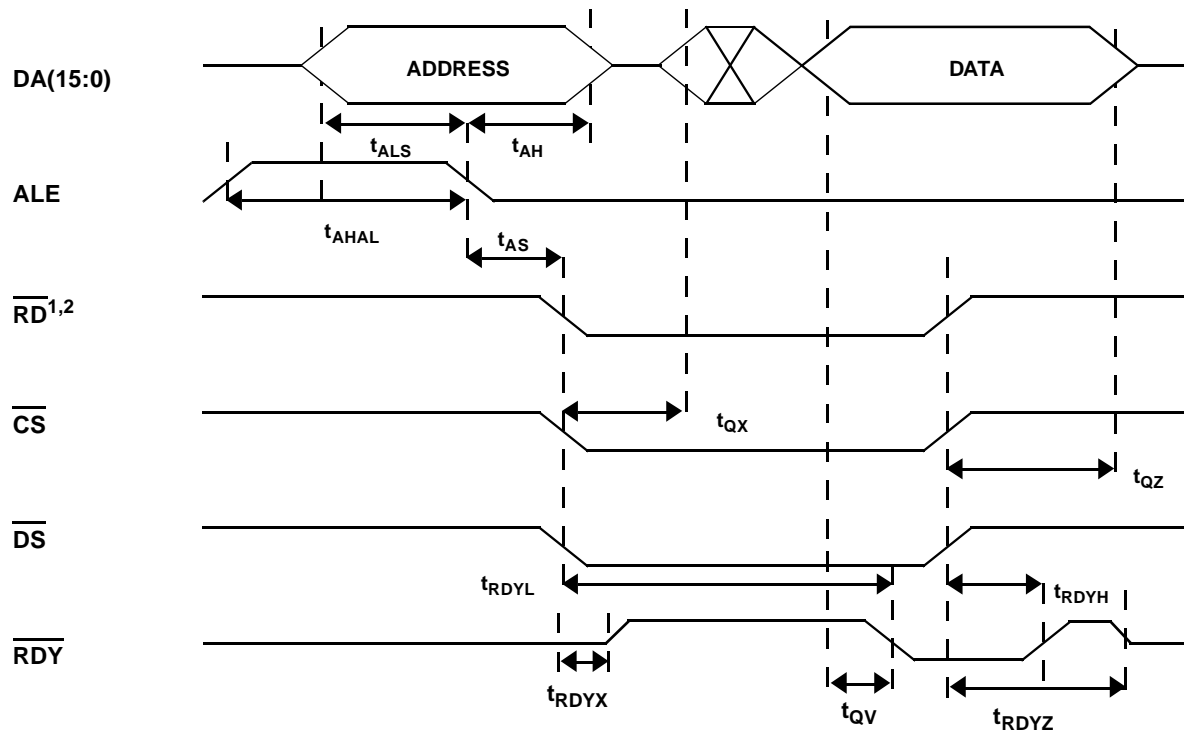

| SYMBOL | PARAMETER | MINIMUM | MAXIMUM | UNITS |
|------------|--|---------|-------------------|-------|
| t_{AS} | Address setup time ⁴ | 0 | -- | ns |
| t_{AHAL} | ALE pulse width ⁴ | 20 | -- | ns |
| t_{QX} | Data low Z ⁴ | 0 | 30 | ns |
| t_{AH} | Address hold time | 5 | -- | ns |
| t_{QV} | Data valid | 12 | -- | ns |
| t_{QZ} | Data high Z | 3 | 32 | ns |
| t_{RDYL} | \overline{RDY} low time (non-contended) ⁴ | -- | 245 | ns |
| t_{RDYL} | \overline{RDY} low time (contended) ⁴ | -- | 1700 ³ | ns |
| t_{RDYH} | \overline{RDY} high time ⁴ | 0 | 25 | ns |
| t_{RDYX} | \overline{RDY} low Z ⁴ | 3 | -- | ns |
| t_{RDYZ} | \overline{RDY} high Z ⁴ | -- | 33 | ns |
| t_{ALS} | Address latch setup time ⁴ | 5 | -- | ns |

Notes:

1. A cycle begins on the latter falling edge of \overline{CS} , \overline{DS} and \overline{RD} .
2. A cycle ends on the rising edge of either \overline{CS} , \overline{DS} and \overline{RD} .
3. Non-buffered mode of operation.
4. Guaranteed by design, not tested.

Figure 46. Multiplexed Memory/Register Read (8-Bit)

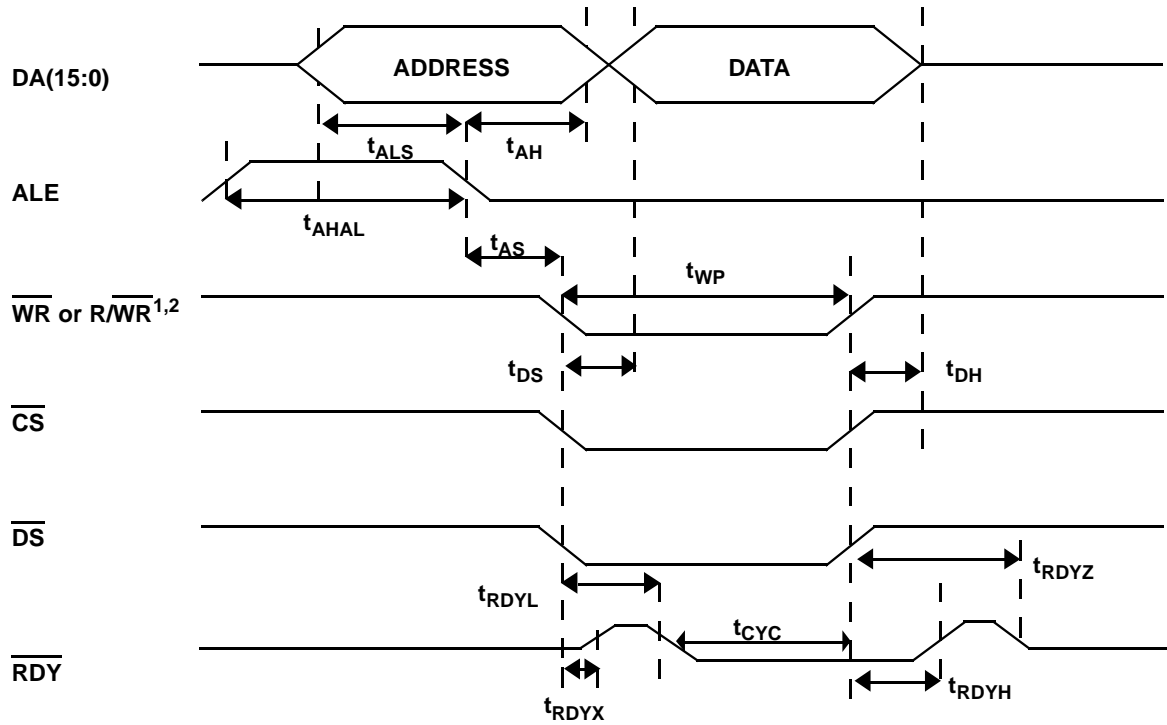

| SYMBOL | PARAMETER | MINIMUM | MAXIMUM | UNITS |
|------------|--|---------------------|-------------------|-------|
| t_{AS} | Address setup time ⁵ | 0 | -- | ns |
| t_{AHAL} | ALE pulse width ⁵ | 20 | -- | ns |
| t_{DS} | Data setup time ⁵ | -- | 20 | ns |
| t_{WP} | Write pulse width (non-contended) ⁵ | 230 ⁴ | -- | ns |
| t_{WP} | Write pulse width (contended) ⁵ | 1700 ^{3,4} | -- | ns |
| t_{AH} | Address hold time ⁵ | 5 | -- | ns |
| t_{DH} | Data hold time ⁵ | 5 | -- | ns |
| t_{RDYL} | \overline{RDY} low time (non-contended) ⁵ | -- | 245 | ns |
| t_{RDYL} | \overline{RDY} low time (contended) ⁵ | -- | 1700 ³ | ns |
| t_{RDYH} | \overline{RDY} high time ⁵ | 0 | 25 | ns |
| t_{RDYX} | \overline{RDY} low Z ⁵ | 3 | -- | ns |
| t_{RDYZ} | \overline{RDY} high Z ⁵ | -- | 33 | ns |
| t_{ALS} | Address latch setup time ⁵ | 5 | -- | ns |
| t_{CYC} | Minimum cycle time ⁵ | 20 | -- | ns |

Notes:

1. A cycle begins on the latter falling edge of \overline{CS} , \overline{DS} and \overline{WR} or R/\overline{WR}
2. A cycle ends on the rising edge of either \overline{CS} , \overline{DS} and \overline{WR} or R/\overline{WR} .
3. Non-buffered mode of operation.
4. For applications not using \overline{RDY} signal.
5. Guaranteed by design, not tested.

Figure 47. Multiplexed Memory/Register Write (16-Bit)

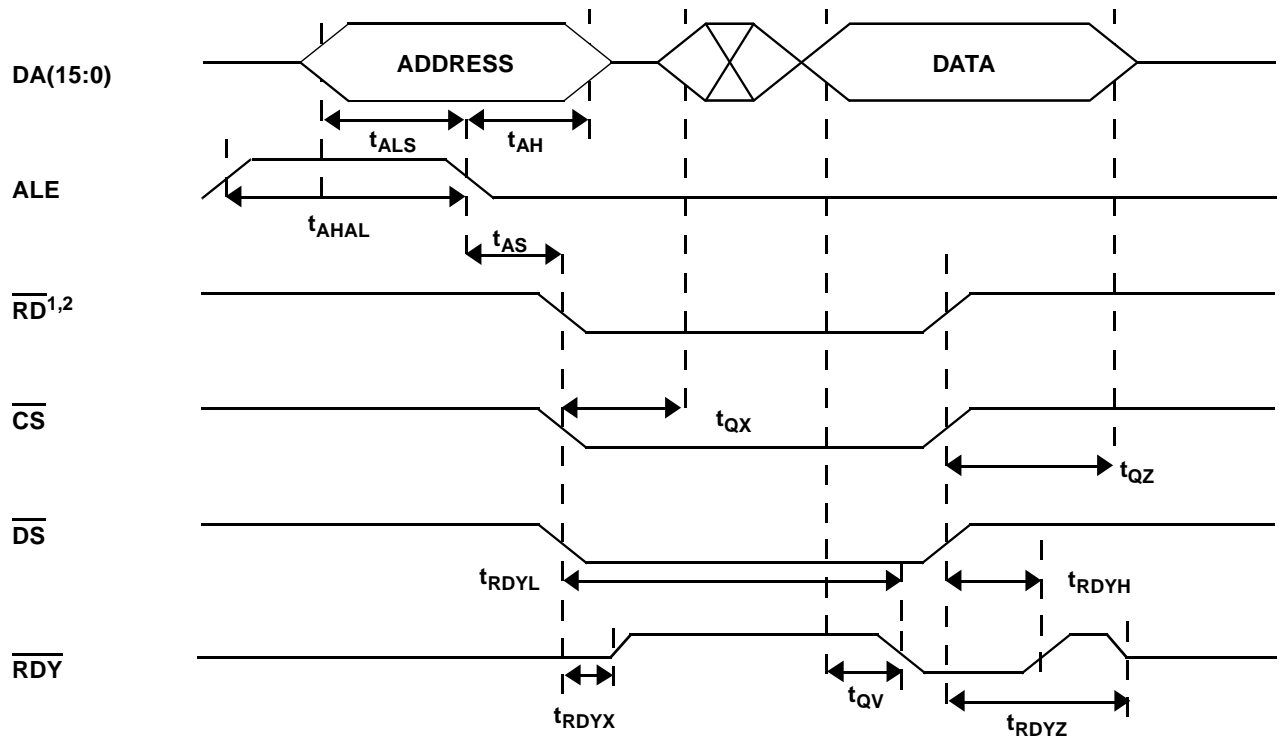

| SYMBOL | PARAMETER | MINIMUM | MAXIMUM | UNITS |
|------------|--|---------|-------------------|-------|
| t_{AS} | Address setup time ⁴ | 0 | -- | ns |
| t_{AHAL} | ALE pulse width ⁴ | 20 | -- | ns |
| t_{QX} | Data low Z ⁴ | 0 | 30 | ns |
| t_{AH} | Address hold time ⁴ | 5 | -- | ns |
| t_{QV} | Data valid ⁴ | 20 | -- | ns |
| t_{QZ} | Data high Z ⁴ | 3 | 32 | ns |
| t_{RDYL} | \overline{RDY} low time (non-contended) ⁴ | -- | 245 | ns |
| t_{RDYL} | \overline{RDY} low time (contended) ⁴ | -- | 1700 ³ | ns |
| t_{RDYH} | \overline{RDY} high time ⁴ | 0 | 25 | ns |
| t_{RDYX} | \overline{RDY} low Z ⁴ | 3 | -- | ns |
| t_{RDYZ} | \overline{RDY} high Z ⁴ | -- | 33 | ns |
| t_{ALS} | Address latch setup time ⁴ | 5 | -- | ns |

Notes:

1. A cycle begins on the latter falling edge of \overline{CS} , \overline{DS} and \overline{RD} .
2. A cycle ends on the rising edge of either \overline{CS} , \overline{DS} and \overline{RD} .
3. Non-buffered mode of operation.
4. Guaranteed by design, not tested.

Figure 48. Multiplexed Memory/Register Read (16-Bit)

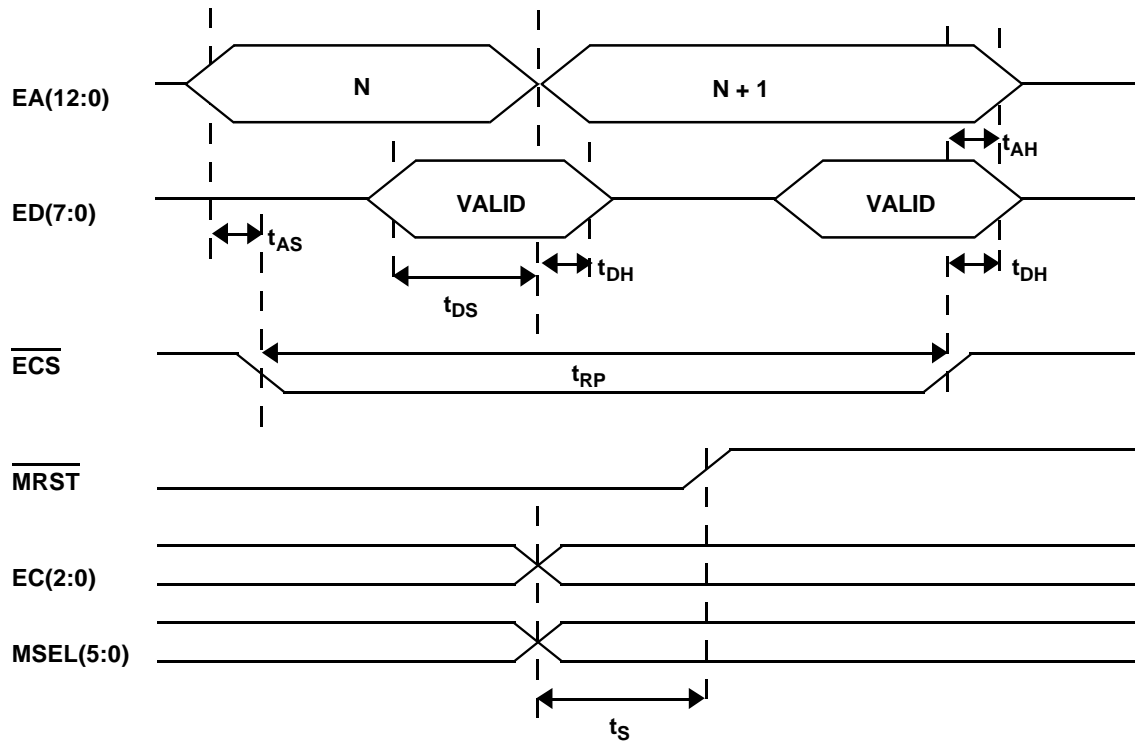

| SYMBOL | PARAMETER | MINIMUM | MAXIMUM | UNITS |
|----------|---------------------------------|---------|---------|-------|
| t_{AS} | Address setup time ¹ | 35 | -- | ns |
| t_{AH} | Address hold time ¹ | 35 | -- | ns |
| t_{DS} | Data setup time ¹ | 41 | -- | ns |
| t_{DH} | Data hold time ¹ | 5 | -- | ns |
| t_{RP} | Read pulse width ¹ | 160 | -- | ns |
| t_s | Setup time ¹ | 45 | -- | ns |

Notes:

1. Guaranteed by design, not tested.

Figure 49. Auto-Initialization Read Cycle

Address Bus
 A(15:0), A(14:0), DA(15:0),
 or DA(14:0)

Control Signals
 (DS, CS, RD, R/WR)

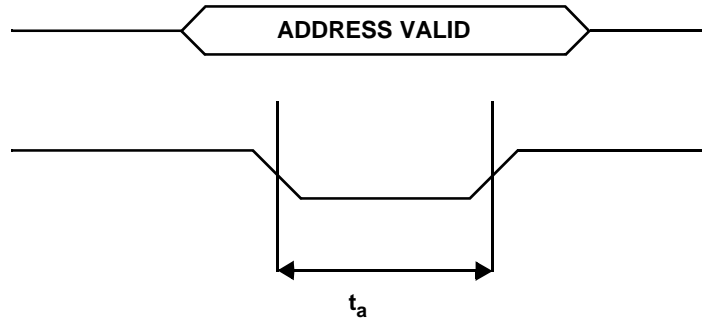

| SYMBOL | PARAMETER | MINIMUM | MAXIMUM | UNITS |
|--------|---|---------|---------|---------|
| t_a | Maximum Register/Memory Time Bus Controller ¹ | -- | 16 | μ s |
| | Remote Terminal ¹ | -- | 7 | μ s |
| | Remote Terminal and Monitor ¹ | -- | 7 | μ s |
| | Monitor ¹ | -- | 7 | μ s |

Notes:

1. Guaranteed by design, not tested.

Figure 50. Maximum Cycle Time

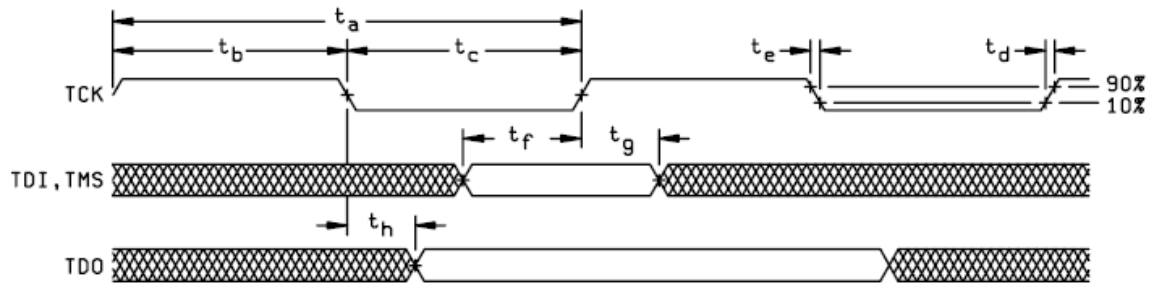

| SYMBOL | PARAMETER | MIN | MAX | UNITS |
|--------|---------------------|----------|-----|-------|
| t_a | TCK frequency | - | 1 | MHz |
| t_a | TCK period | 1000 | - | ns |
| t_b | TCK high time | $1/2t_a$ | - | ns |
| t_c | TCK low time | $1/2t_a$ | - | ns |
| t_d | TCK rise time | - | 5 | ns |
| t_e | TCK fall time | - | 5 | ns |
| t_f | TDI, TMS setup time | 250 | - | ns |
| t_g | TDI, TMS hold time | 250 | - | ns |
| t_h | TDO valid delay | 250 | - | ns |

Figure 51. JTAG Timing

22.0 S μ MMIT LXE/DXE & S μ MMIT XTE RECEIVER ELECTRICAL CHARACTERISTICS

22.1 S μ MMIT LXE & XTE (15 & 12) Receiver Electrical Characteristics

$$V_{DD} = 5.0V \pm 10\%$$

$$V_{SS} = 0V$$

$$V_{CC} = 5.0V +10\%, -5\%$$

$$GND = 0V$$

$$V_{EE} = -12.0V \text{ or } -15.0V \pm 5\%$$

$$-55^{\circ}C < T_C < +125^{\circ}C$$

| SYMBOL | PARAMETER | CONDITION | MINIMUM | MAXIMUM | UNIT |
|------------|--|--|------------------------|----------|--------------|
| R_{IZ}^1 | Differential (receiver) input impedance | Input $f = 1\text{MHz}$ (no transformer in circuit) | 15 | | Kohms |
| V_{IC}^3 | Common mode input voltage | Direct-coupled stub; input $1.2V_{PP}$, 200ns rise/fall time $\pm 25\text{ns}$, $f = 1\text{MHz}$ | -10 | +10 | V |
| V_{TH} | Input threshold voltage (no response) ¹ | Transformer-coupled stub; input at $f = 1\text{MHz}$, rise/fall time 200ns (Receiver output 0 \rightarrow 1 transition) | | 0.20 | $V_{PP,L-L}$ |
| | Input threshold voltage (no response) | Direct-coupled stub; input at $f = 1\text{MHz}$, rise/fall time 200ns (Receiver output 0 \rightarrow 1 transition) | | 0.28 | $V_{PP,L-L}$ |
| | Input threshold voltage (response) ¹ | Transformer-coupled stub; input at $f = 1\text{MHz}$, rise/fall time 200ns (Receiver output 0 \rightarrow 1 transition) | 0.86 | 14.0 | $V_{PP,L-L}$ |
| | Input threshold voltage (response) | Direct-coupled stub; input at $f = 1\text{MHz}$, rise/fall time 200ns (Receiver output 0 \rightarrow 1 transition) | 1.20 | 20.0^1 | $V_{PP,L-L}$ |
| $CMRR^1$ | Common mode rejection ratio | | Pass/Fail ² | | N/A |

Notes:

1. Guaranteed by device characterization, not tested.

2. Pass/fail criteria per the test method described in MIL-HDBK-1553 Appendix A, RT Validation Test Plan, Section 5.1.2.2, Common Mode Rejection.

3. Guaranteed by design, not tested.

22.2 S μ MMIT DXE & XTE (5) Receiver Electrical Characteristics

V_{DD} = 5.0V \pm 10%

GND = 0V

V_{CC} = 5.0V \pm 10%

-55°C < T_C < +125°C

V_{SS} = 0V

| SYMBOL | PARAMETER | CONDITION | MINIMUM | MAXIMUM | UNIT |
|------------------------------|--|---|-----------|---------|---------------------|
| V _{IC} ³ | Common mode input voltage | Direct-coupled stub; input 1.2V _{PP} , 200ns rise/fall time \pm 25ns, f = 1MHz | -10 | +10 | V |
| V _{TH} | Input threshold voltage (no response) ³ | Transformer-coupled stub; input at f = 1MHz, rise/fall time 200ns at (Receiver output 0 \rightarrow 1 transition) | | 0.20 | V _{PP,L-L} |
| | Input threshold voltage (no response) | Direct-coupled stub; input at f = 1MHz, rise/fall time 200ns at (Receiver output 0 \rightarrow 1 transition) | | 0.28 | V _{PP,L-L} |
| | Input threshold voltage (response) ³ | Transformer-coupled stub; input at f = 1MHz, rise/fall time 200ns at (Receiver output 0 \rightarrow 1 transition) | 0.86 | 14.0 | V _{PP,L-L} |
| | Input threshold voltage (response) ³ | Direct-coupled stub; input at f = 1MHz, rise/fall time 200ns at (Receiver output 0 \rightarrow 1 transition) | 1.20 | 20.0 | V _{PP,L-L} |
| CMRR ^{1,2} | Common mode rejection ratio | | Pass/Fail | | N/A |

Notes:

1. Guaranteed by device characterization, not tested.
2. Pass/fail criteria per the test method described in MIL-HDBK-1553 Appendix A, RT Validation Test Plan, Section 5.1.2.2, Common Mode Rejection.
3. Guaranteed by design, not tested.

23.0 S μ MMIT LXE/DXE & S μ MMIT XTE TRANSMITTER ELECTRICAL CHARACTERISTICS

23.1 S μ MMIT LXE & XTE (15 & 12) Transmitter Electrical Characteristics

$$V_{DD} = 5.0V \pm 10\%$$

$$V_{SS} = 0V$$

$$V_{CC} = 5.0V +10\%, -5\%$$

$$GND = 0V$$

$$V_{EE} = -12.0V \text{ or } -15.0V \pm 5\%$$

$$-55^{\circ}C < T_C < +125^{\circ}C$$

| SYMBOL | PARAMETER | MINIMUM | MAXIMUM | UNIT | CONDITION |
|----------------|---|---------|---------|------------------------|---|
| V_O | Output voltage swing per MIL-STD-1553B ³ (see figure 52) | 18 | 27 | $V_{PP,L-L}$ | Transformer-coupled stub, figure 51, Point A; input $f = 1\text{MHz}$, $R_L = 70$ ohms |
| | per MIL-STD-1553B (see figure 52) | 6.0 | 9 | $V_{PP,L-L}$ | Direct-coupled stub, figure 51, Point A; input $f = 1\text{MHz}$, $R_L = 35$ ohms |
| | per MIL-STD-1553A ³ (see figure 52) | 6.0 | 20 | $V_{PP,L-L}$ | Figure 51, Point A; input $f = 1\text{MHz}$, $R_L = 35$ ohms |
| V_{NS}^1 | Output noise voltage differential (see figure 52) | | 14 | mV-RMS _{L-L} | Transformer-coupled stub, figure 51, Point A; input $f = \text{DC to } 10\text{MHz}$, $R_L = 70$ ohms |
| | | | 5 | mV-RMS _{L-L} | Direct-coupled stub, figure 51, Point A; input $f = \text{DC to } 10\text{MHz}$, $R_L = 35$ ohms |
| $V_{OS}^{1,2}$ | Output symmetry (see figure 52) | -250 | +250 | mV _{PP,L-L} | Transformer-coupled stub, figure 51, Point A; $R_L = 70$ ohms, measurement taken $2.5\mu\text{s}$ after end of transmission |
| | | -90 | +90 | mV _{PP,L-L} | Direct-coupled stub, figure 51, Point A; $R_L = 35$ ohms, measurement taken $2.5\mu\text{s}$ after end of transmission |
| V_{DIS}^1 | Output voltage distortion (overshoot or ring) (see figure 52) | -900 | +900 | mV _{peak,L-L} | Transformer-coupled stub, figure 51, Point A; $R_L = 70$ ohms |
| | | -300 | +300 | mV _{peak,L-L} | Direct-coupled stub, figure 51, Point A; $R_L = 35$ ohms |
| T_{IZ}^1 | Terminal input impedance | 1 | | Kohm | Transformer-coupled stub, figure 51, Point A; input $f = 75\text{KHz to } 1\text{MHz}$ (power on or power off; non-transmitting, R_L removed from circuit). |
| | | 2 | | Kohm | Direct-coupled stub, figure 51, Point A; input $f = 75\text{KHz to } 1\text{MHz}$ (power on or power off; non-transmitting, R_L removed from circuit). |

Note:

1. Guaranteed by device characterization, not tested.

2. Tested in accordance with the method described in MIL-STD-1553B output symmetry, section 4.5.2.1.1.4.

3. Guaranteed by design, not tested.

23.2 S μ MMIT DXE & XTE (5) Transmitter Electrical Characteristics

V_{DD} = 5.0V \pm 10%
V_{CC} = 5.0V \pm 10%
V_{SS} = 0V

GND = 0V
-55°C < T_C < +125°C

| SYMBOL | PARAMETER | MINIMUM | MAXIMUM | UNIT | CONDITION |
|--------------------------------|---|---------|---------|------------------------|--|
| V _O | Output voltage swing per MIL-STD-1553B ¹ (see figure 52) | 18 | 27 | V _{PP,L-L} | Transformer-coupled stub, figure 51, Point A; input $f = 1\text{MHz}$, R _L = 70 ohms |
| | per MIL-STD-1553B (see figure 52) | 6.0 | 9 | V _{PP,L-L} | Direct-coupled stub, figure 51, Point A; input $f = 1\text{MHz}$, R _L = 35 ohms |
| | per MIL-STD-1553A ¹ (see figure 52) | 6.0 | 20 | V _{PP,L-L} | |
| V _{NS} ¹ | Output noise voltage differential (see figure 52) | | 14 | mV-RMS _{L-L} | Transformer-coupled stub, figure 51, Point A; input $f = \text{DC to } 10\text{MHz}$, R _L = 70 ohms |
| | | | 5 | mV-RMS _{L-L} | Direct-coupled stub, figure 51, Point A; input $f = \text{DC to } 10\text{MHz}$, R _L = 35 ohms |
| V _{OS} ^{1,2} | Output symmetry (see figure 52) | | +250 | mV _{PP,L-L} | Transformer-coupled stub, figure 51, Point A; R _L = 70 ohms, measurement taken 2.5 μ s after end of transmission |
| | | | -90 | mV _{PP,L-L} | Direct-coupled stub, figure 51, Point A; R _L = 35 ohms, measurement taken 2.5 μ s after end of transmission |
| V _{DIS} ¹ | Output voltage distortion (overshoot or ring) (see figure 52) | | +900 | mV _{peak,L-L} | Transformer-coupled stub, figure 51, Point A; R _L = 70 ohms |
| | | | -300 | mV _{peak,L-L} | Direct-coupled stub, figure 51, Point A; R _L = 35 ohms |
| T _{IZ} ¹ | Terminal input impedance | 1 | | Kohm | Transformer-coupled stub, figure 51, Point A; input $f = 75\text{KHz to } 1\text{MHz}$ (power on or power off; non-transmitting, R _L removed from circuit). |
| | | 2 | | Kohm | Direct-coupled stub, figure 51, Point A; input $f = 75\text{KHz to } 1\text{MHz}$ (power on or power off; non-transmitting, R _L removed from circuit). |

Note:

1. Guaranteed by device characterization, not tested.
2. Tested in accordance with the method described in MIL-STD-1553B output symmetry, section 4.5.2.1.1.4.

24.0 S μ MMIT LXE/DXE & S μ MMIT XTE AC ELECTRICAL CHARACTERISTICS

24.1 S μ MMIT LXE & XTE (15 & 12) AC Electrical Characteristics

$$V_{DD} = 5.0V \pm 10\%$$

$$V_{SS} = 0V$$

$$V_{CC} = 5.0V +10\%, -5\%$$

$$GND = 0V$$

$$V_{EE} = -12.0V \text{ or } -15.0V \pm 5\%$$

$$-55^{\circ}C < T_C < +125^{\circ}C$$

| SYMBOL | PARAMETER | MINIMUM | MAXIMUM | UNIT | CONDITION |
|------------|---|---------|---------|------|---|
| t_R, t_F | Transmitter output rise/fall time (see figure 53) | 100 | 300 | ns | Input $f = 1\text{MHz}$ 50% duty cycle: direct-coupled $RL = 35$ ohms output at 10% through 90% points TXOUT, $\overline{\text{TXOUT}}$. Figure 53. |
| t_{RZCD} | Zero crossing distortion (see figure 54) | -150 | 150 | ns | Direct-coupled stub; input $f = 1\text{MHz}$, $3 V_{PP}$ (skew INPUT $\pm 150\text{ns}$), rise/fall time 200ns. |
| t_{TZCS} | Zero crossing stability (see figure 54) | -25 | 25 | ns | Input TXIN and $\overline{\text{TXIN}}$ should create Transmitter output zero crossings at 500ns, 1000ns, 1500ns, and 2000ns. These zero crossings should not deviate more than $\pm 25\text{ns}$. |

24.2 S μ MMIT DXE & XTE (5) AC Electrical Characteristics

$$V_{DD} = 5.0V \pm 10\%$$

$$GND = 0V$$

$$V_{CC} = 5.0V \pm 10\%$$

$$-55^{\circ}C < T_C < +125^{\circ}C$$

$$V_{SS} = 0V$$

| SYMBOL | PARAMETER | MINIMUM | MAXIMUM | UNIT | CONDITION |
|------------|---|---------|---------|------|---|
| t_R, t_F | Transmitter output rise/fall time (see figure 53) | 100 | 300 | ns | Input $f = 1\text{MHz}$ 50% duty cycle: direct-coupled $RL = 35$ ohms output at 10% through 90% points TXOUT, $\overline{\text{TXOUT}}$. Figure 53. |
| t_{RZCD} | Zero crossing distortion (see figure 54) | -150 | 150 | ns | Direct-coupled stub; input $f = 1\text{MHz}$, $3 V_{PP}$ (skew INPUT $\pm 150\text{ns}$), rise/fall time 200ns. |
| t_{TZCS} | Zero crossing stability (see figure 54) | -25 | 25 | ns | Input TXIN and $\overline{\text{TXIN}}$ should create Transmitter output zero crossings at 500ns, 1000ns, 1500ns, and 2000ns. These zero crossings should not deviate more than $\pm 25\text{ns}$. |

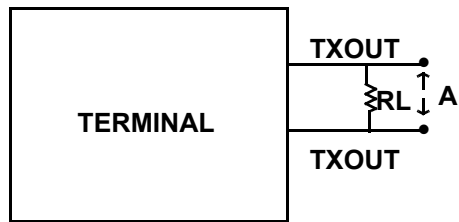

Notes:

1. Transformer Coupled Stub:
Terminal is defined as transceiver plus isolation transformer.
2. Direct Coupled Stub:
Terminal is defined as transceiver plus isolation transformer and fault resistors.

Figure 52. Transceiver Test Circuit MIL-STD-1553B

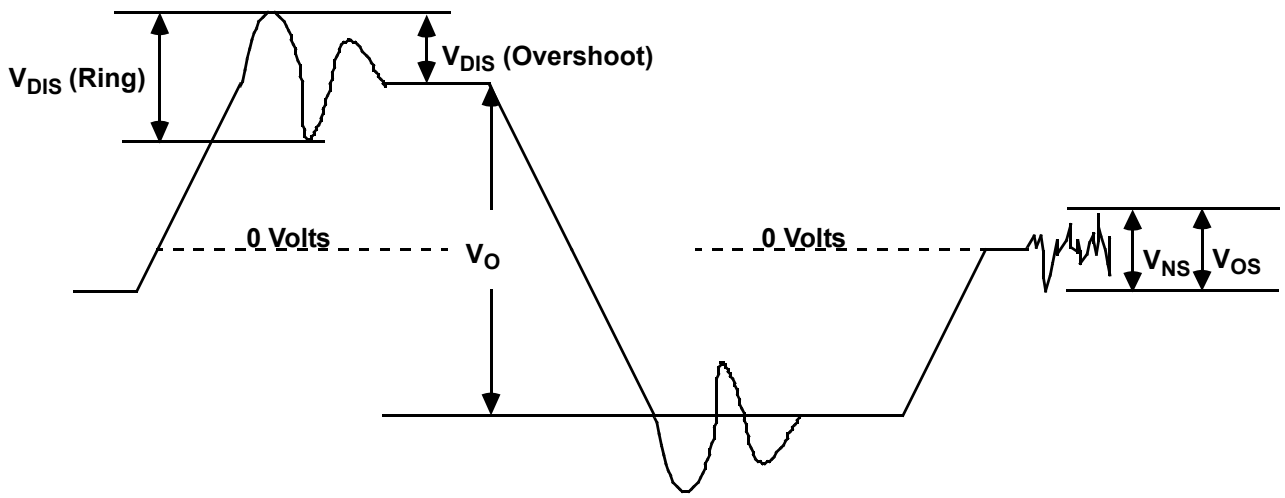

Figure 53. Transmitter Output Characteristics (V_{DIS} , V_{OS} , V_{NS} , V_O)

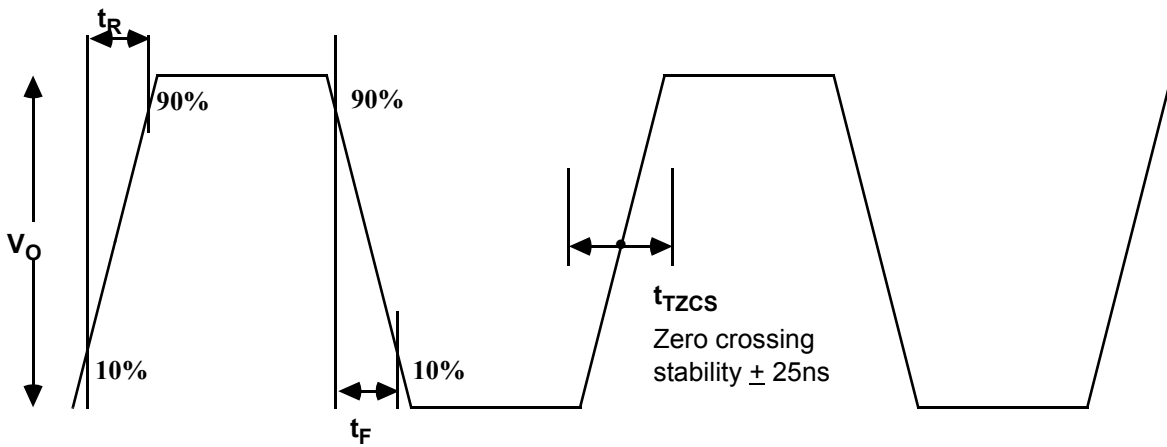

Figure 54. Transmitter Output Zero Crossing Stability, Rise Time, Fall Time (t_{ZCS} , t_R , t_F)

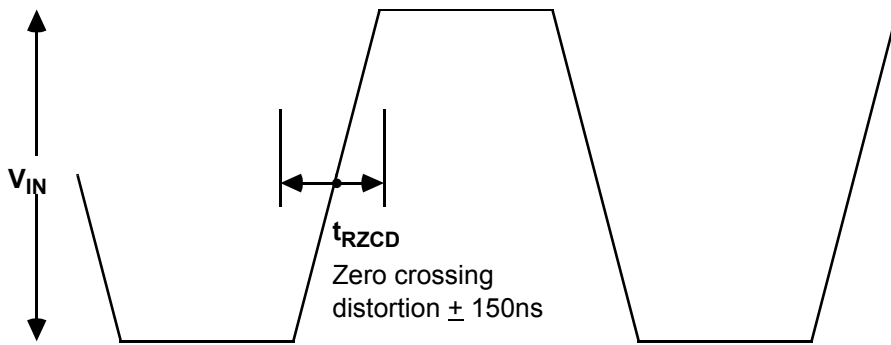

Figure 55. Receiver Input Zero Crossing Distortion (t_{RZCD})

25.0 PACKAGING

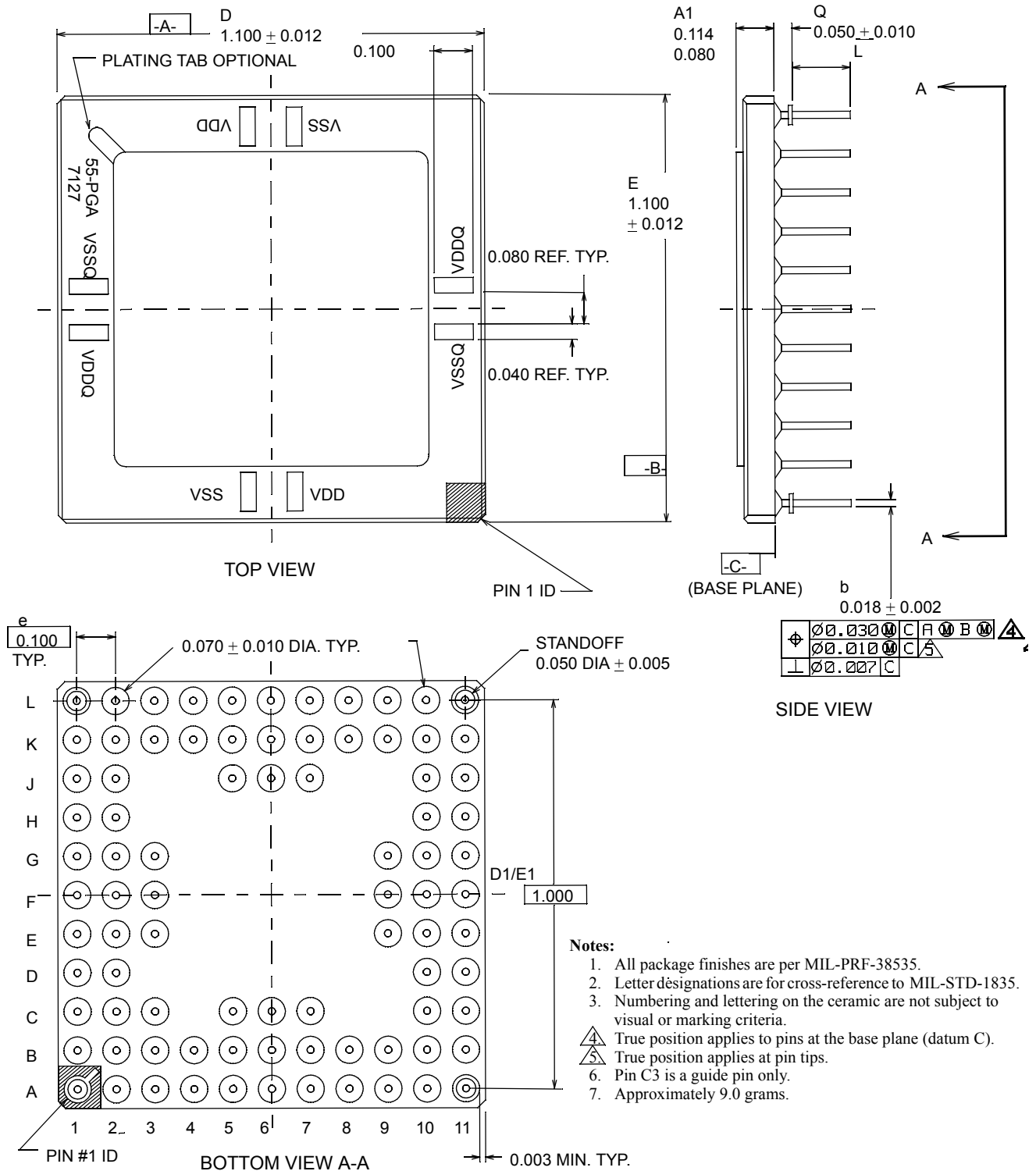
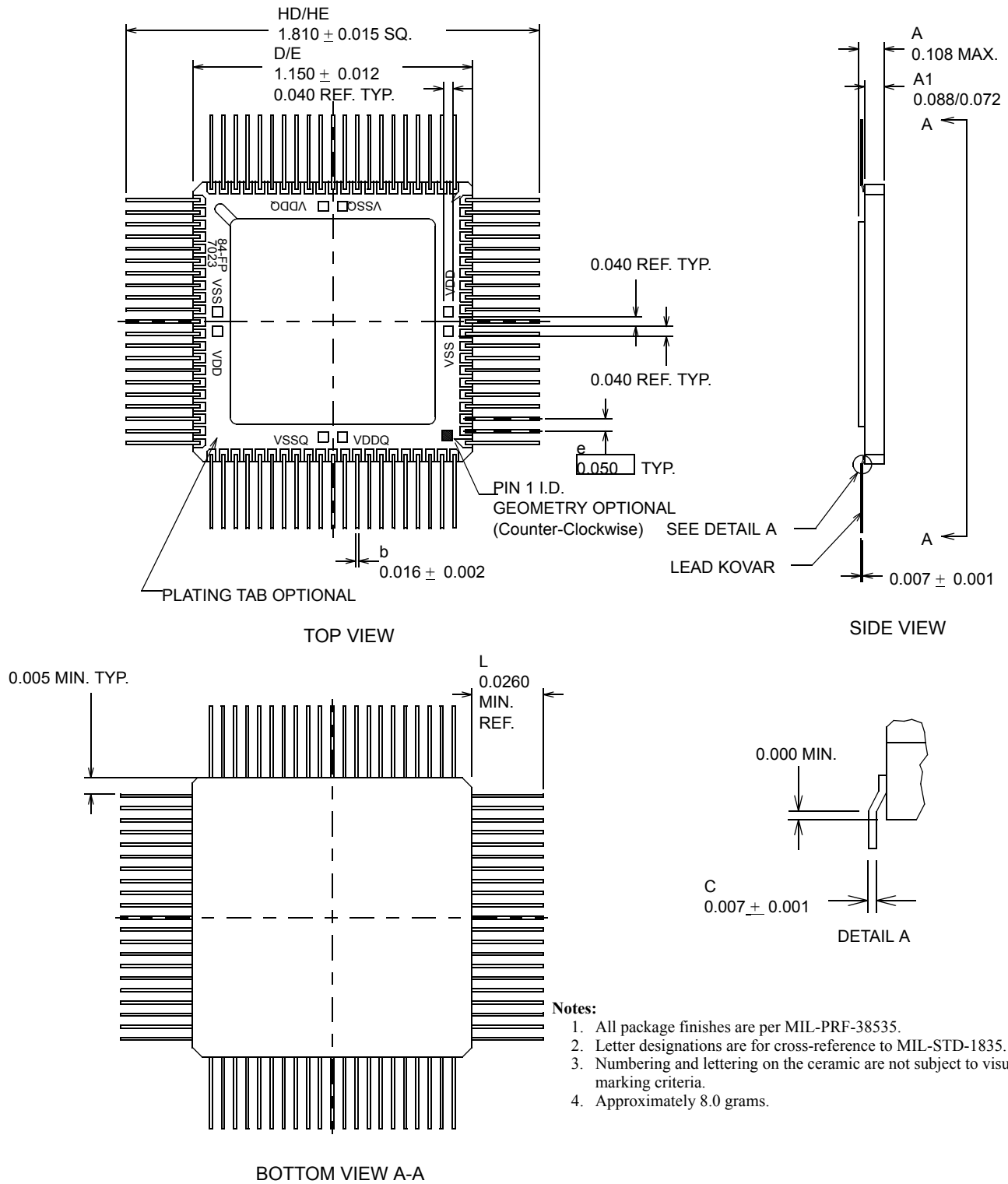

Figure 56. SμMMIT E 85-Pin Pingrid Array



**Figure 57. SμMMIT E 85-Lead Flatpack
 (50mil lead spacing)**

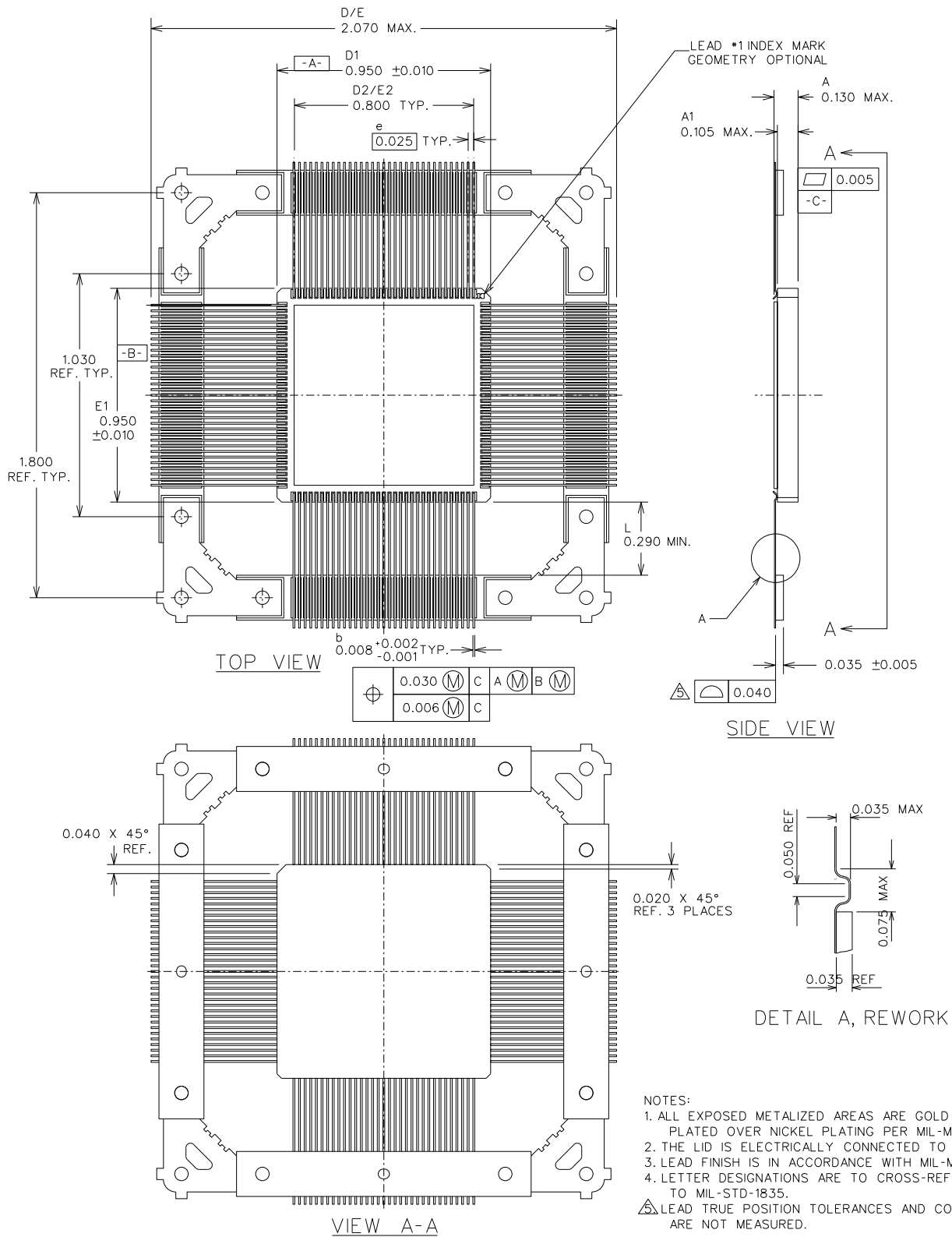
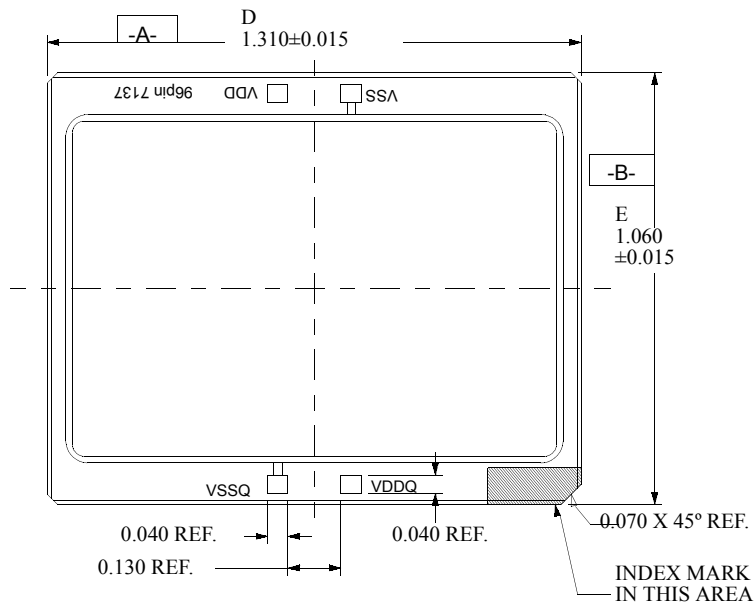
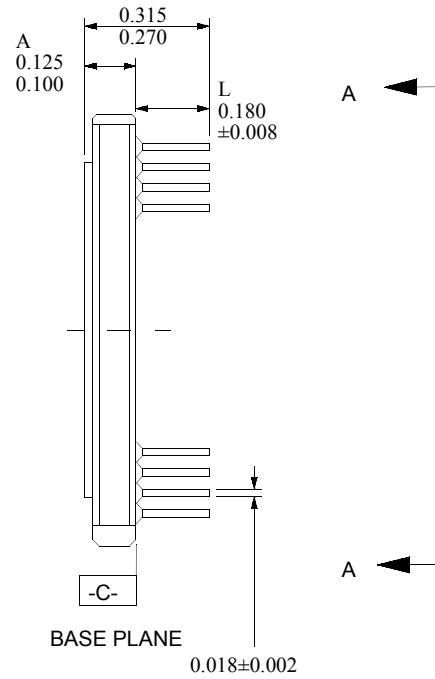

Figure 58. SμMMIT E 132-Lead Flatpack



TOP VIEW



BASE PLANE

0.018 ± 0.002

| | | | | | |
|---|-------------|---|-------|-------|---|
| ⊕ | ∅ 0.030 (M) | C | A (M) | B (M) | 1 |
| | ∅ ?? (M) | C | 2 | | |

SIDE VIEW

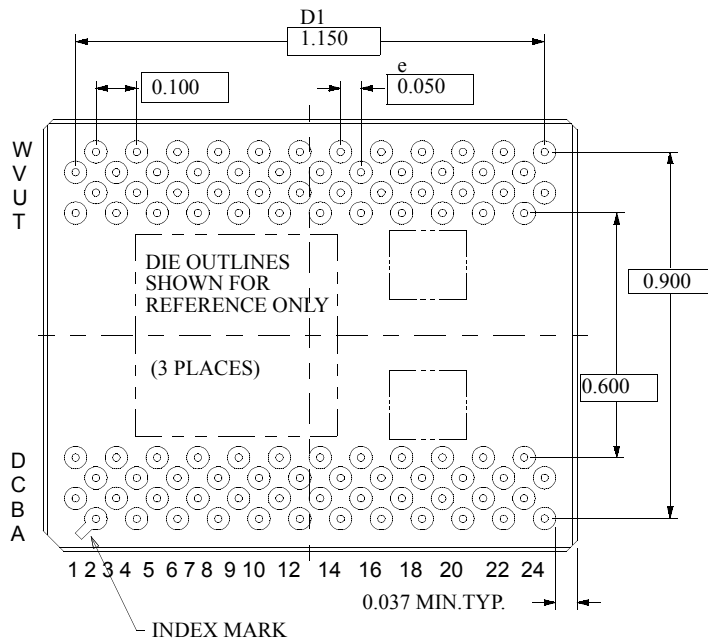

BOTTOM VIEW A-A

Notes:

1. True position applies to pins at base plane (datum C).
2. True position applies at pin tips.
3. All package finishes are per MIL-PRF-38535.
4. Letter designations are for cross-reference to MIL-STD-1835.

Figure 59. SμMMIT LXE/DXE 96-Pin Pingrid Array

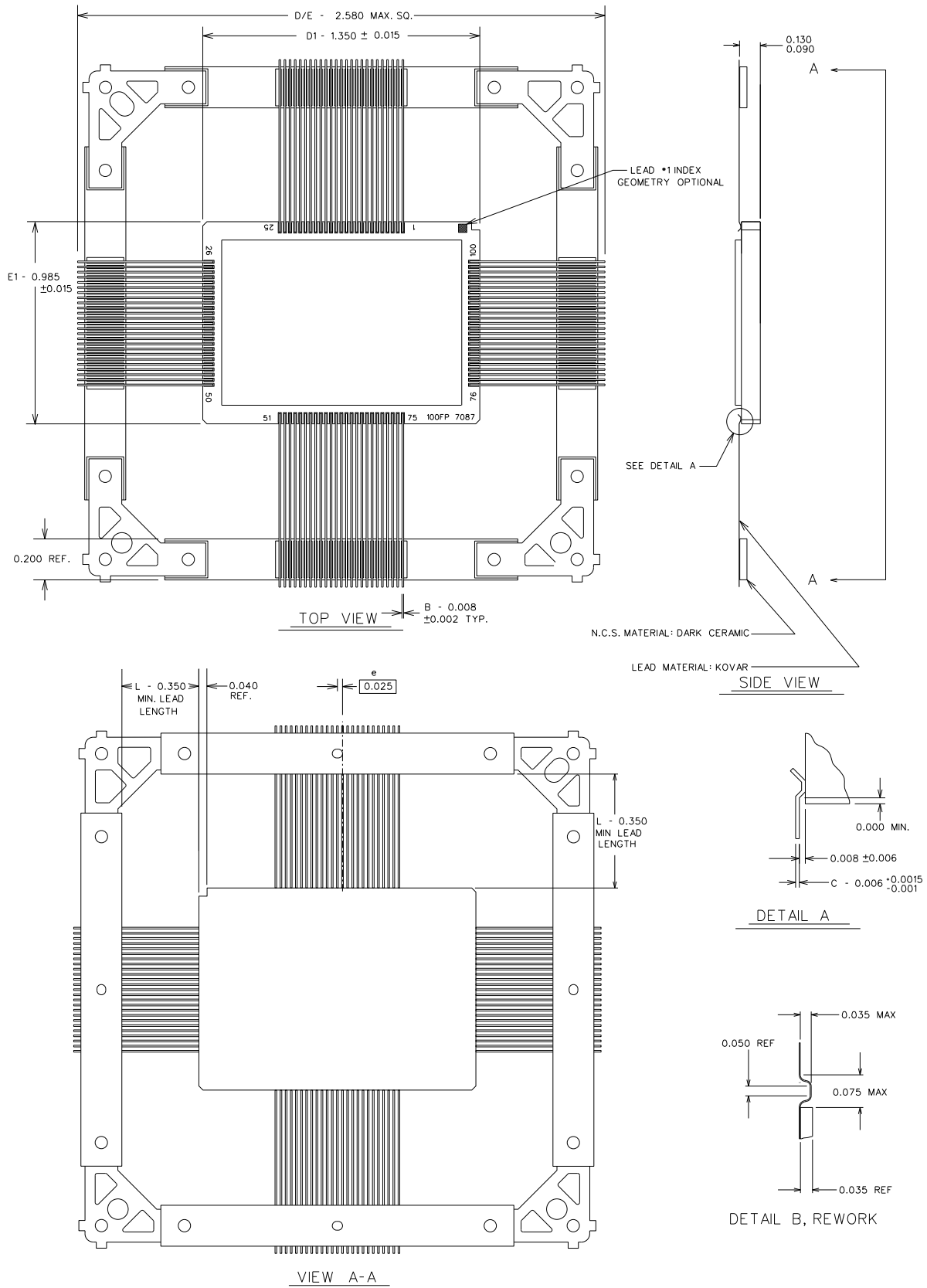
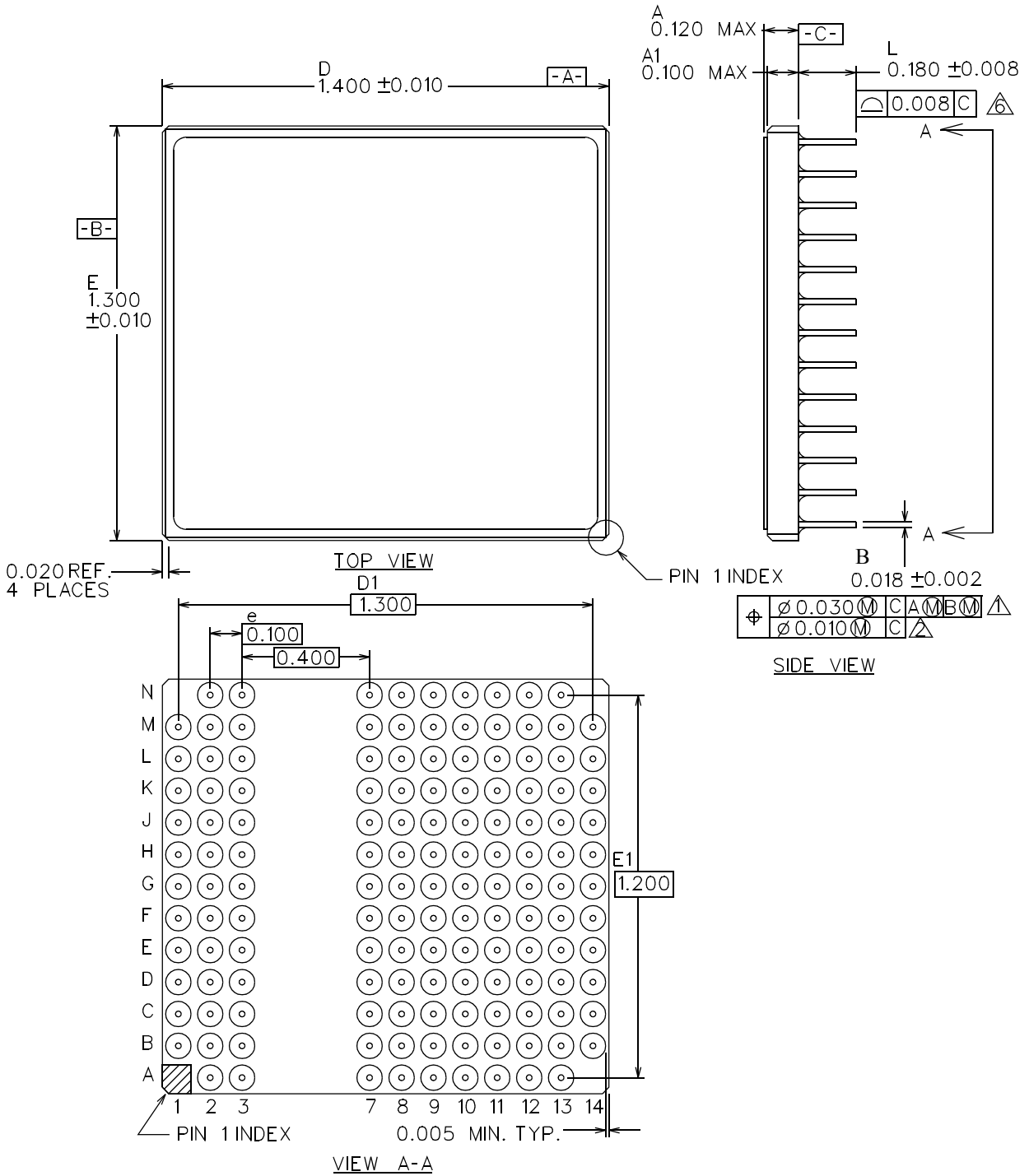

Figure 60. SμMMIT LXE/DXE 100-Lead



- Notes:**
- 1. True position applies to pins at the base plane (Datum C).
 - 2. True position applies at the pin tips.
 - 3. The lid is electrically connected to Vss.
 - 4. Letter designations are for cross-reference to MIL-STD-1835.
 - 5. Lead finish is in accordance with MIL-PRF-38535.
 - 6. Coplanarity is not measured.

Figure 61. SμMMIT XTE 139-Pingrid Array

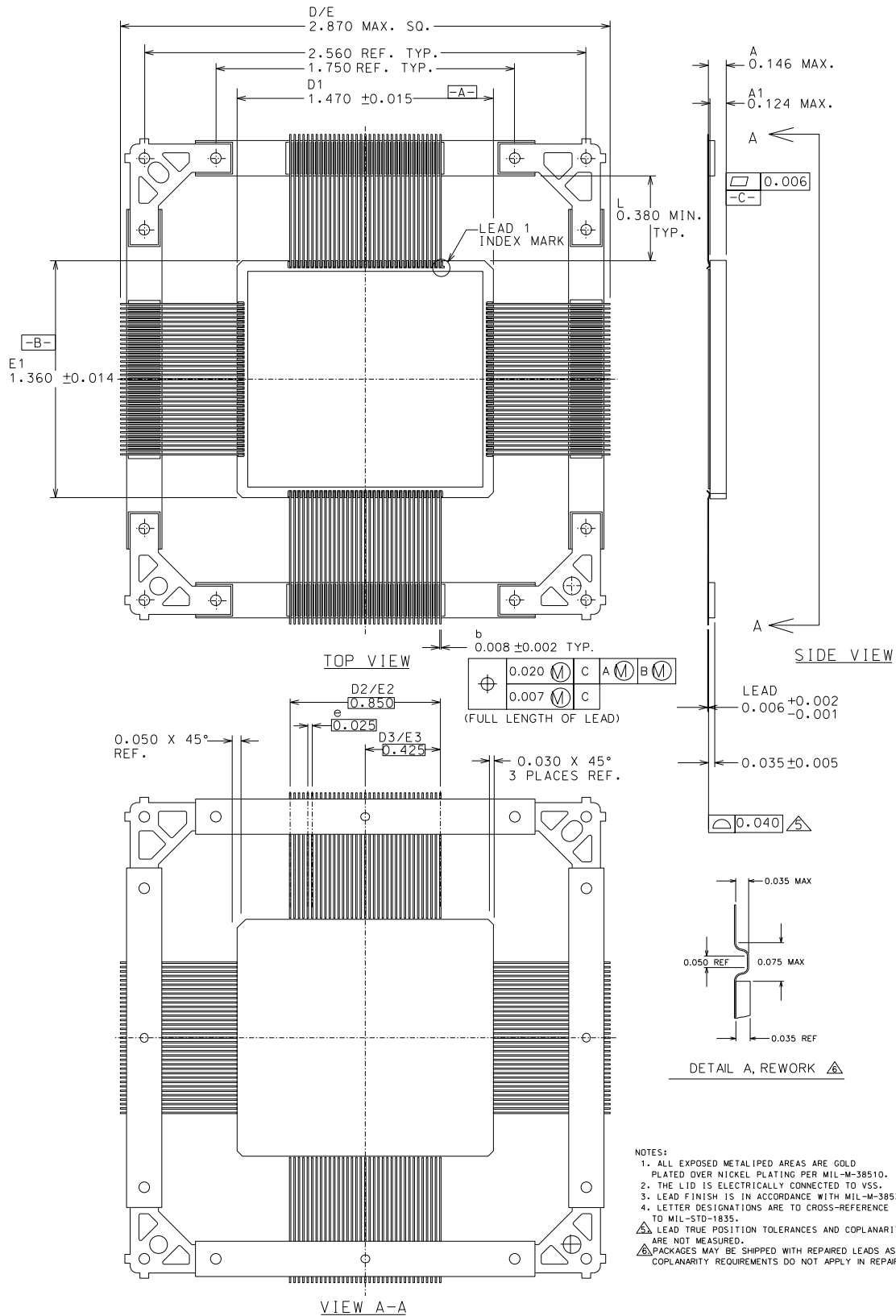
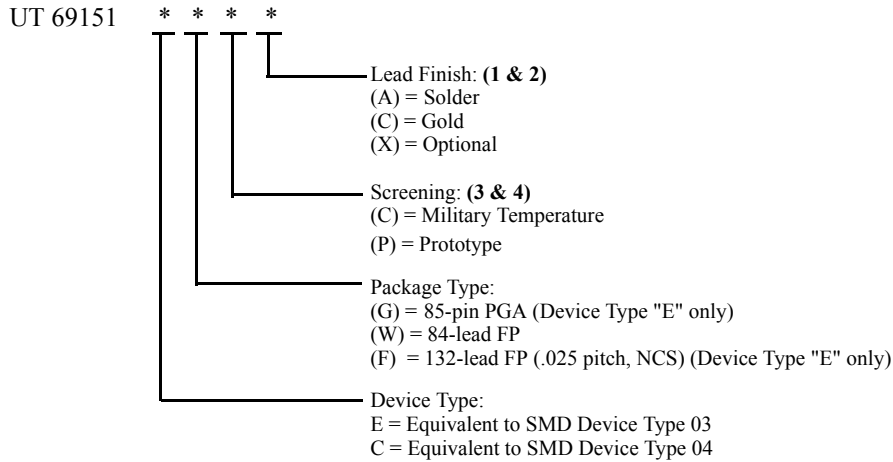

Figure 62. SμMMIT XTE 140-Lead Flatpack

26.0 ORDERING INFORMATION

ENHANCED S μ MMIT E MIL-STD-1553 Dual Redundant Bus Controller/Remote Terminal Monitor



Notes:

1. Lead finish (A,C, or X) must be specified.
2. If an "X" is specified when ordering then the part marking will match the lead finish and will be either "A" (solder) or "C" (gold).
3. Military Temperature Range devices are burned-in and tested at -55°C, room temperature, and +125°C. Radiation neither tested nor guaranteed.
4. Lead finish is at UTMC's option. "X" must be specified when ordering. Radiation neither tested or guaranteed.

ENHANCED S μ MMIT E MIL-STD-1553 Dual Redundant Bus Controller/Remote Terminal Monitor: SMD

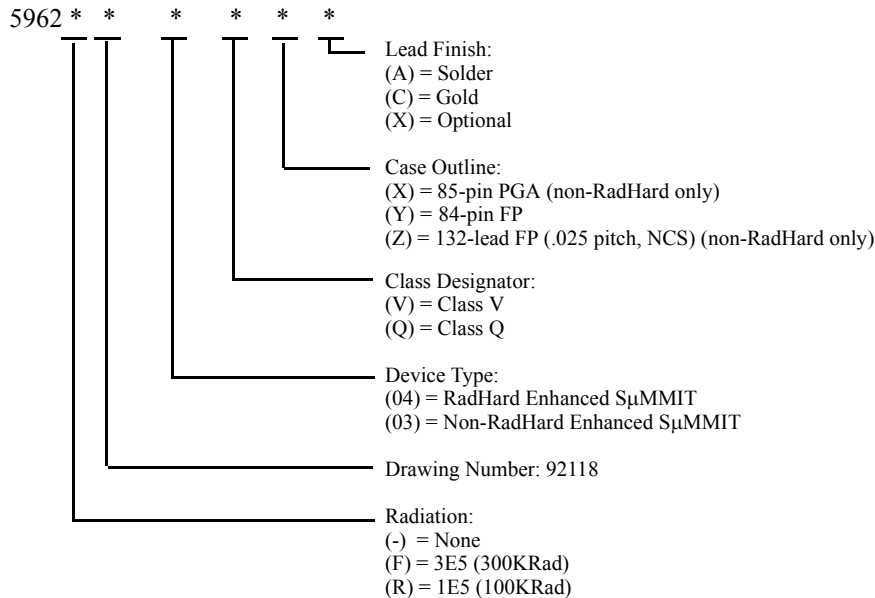

Notes:

1. Lead finish (A,C, or X) must be specified.
2. If an "X" is specified when ordering, part marking will match the lead finish and will be either "A" (solder) or "C" (gold).
3. Device Type 03 not available as rad hard.

ENHANCED S μ MMIT LXE/DXE MIL-STD-1553 Dual Redundant Bus Controller/Remote Terminal/Monitor/Transceiver Multichip Module

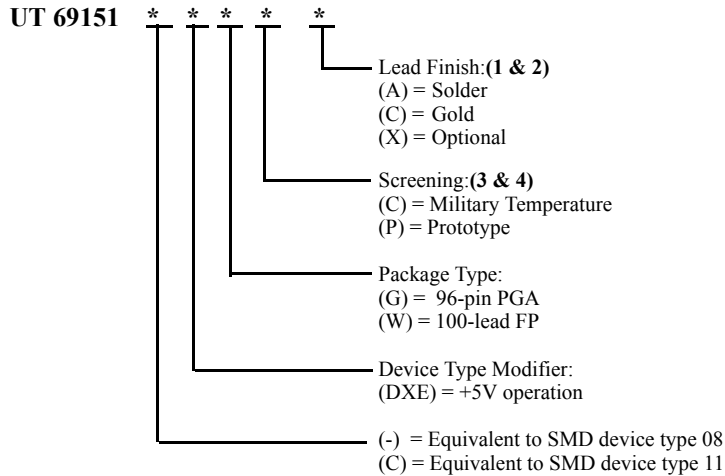

Notes:

1. Lead finish (A,C, or X) must be specified.
2. If an "X" is specified when ordering then the part marking will match the lead finish and will be either "A" (solder) or "C" (gold).
3. Military Temperature Range devices are burned-in and tested at -55°C, room temperature, and +125°C. Radiation neither tested nor guaranteed.
4. Prototype lead finish is gold only. Lead finish is at Aeroflex's option. "X" must be specified when ordering. Radiation neither tested or guaranteed.

ENHANCED S μ MMIT LXE/DXE: MIL-STD-1553 Dual Redundant Bus Controller/Remote Terminal/Monitor/Transceiver Multichip Module: SMD

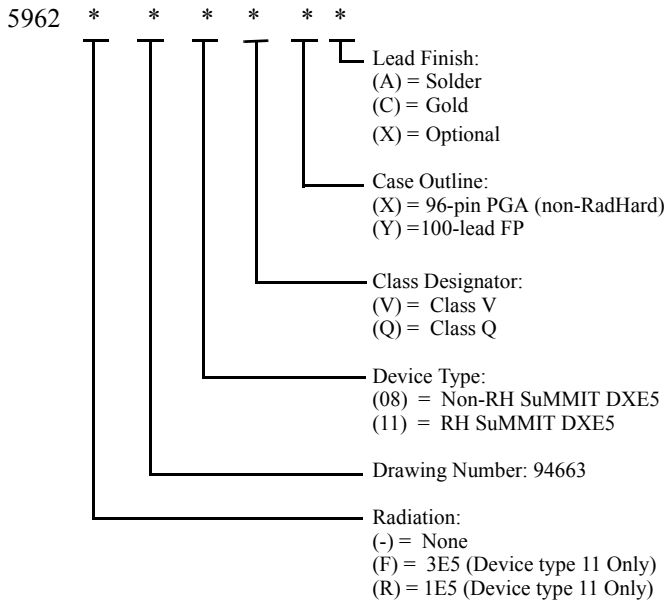

Notes:

1. Lead finish (A,C, or X) must be specified.
2. If an "X" is specified, part marking will match the lead finish and will be either "A" (solder) or "C" (gold).

ENHANCED S μ MMIT XTE MIL-STD-1553 Dual Redundant Bus Controller/Remote Terminal/Monitor/Transceiver Multichip Module

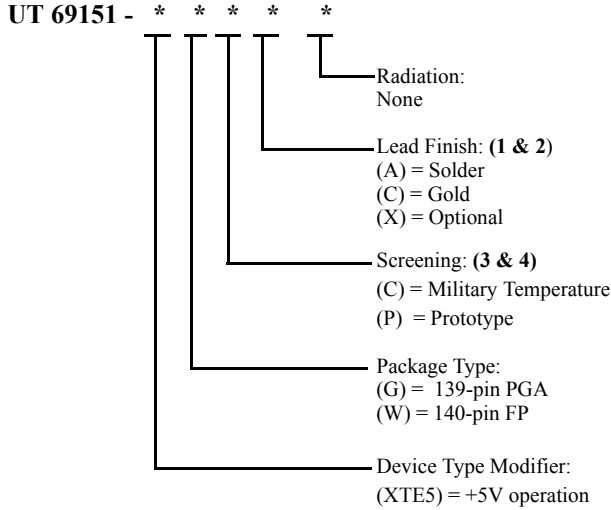

Notes:

1. Lead finish (A,C, or X) must be specified.
2. If an "X" is specified when ordering then the part marking will match the lead finish and will be either "A" (solder) or "C" (gold).
3. Military Temperature Range devices are burned-in and tested at -55°C, room temperature, and +125°C. Radiation neither tested nor guaranteed.
4. Prototype assembly are tested at +25C only. Lead finish is GOLD only. Radiation neither tested or guaranteed.

ENHANCED S μ MMIT XTE: MIL-STD-1553 Dual Redundant Bus Controller/Remote Terminal/Monitor/Transceiver Multichip Module: SMD

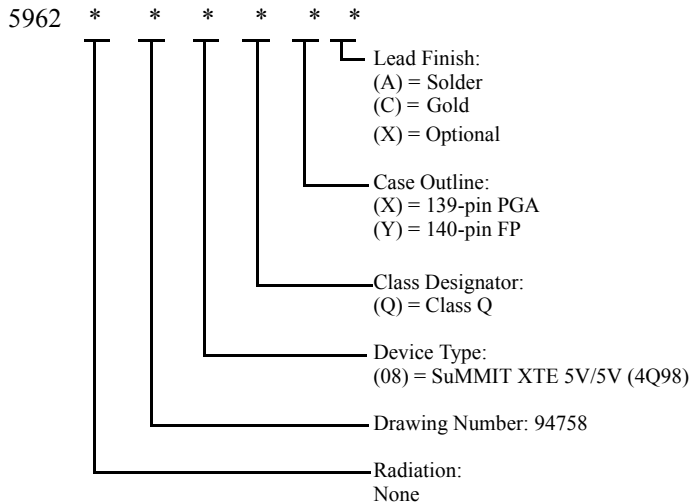

Notes:

1. Lead finish (A,C, or X) must be specified.
2. If an "X" is specified, part marking will match the lead finish and will be either "A" (solder) or "C" (gold).