

Standard Products

ACT4419D Dual Variable Amplitude Transceiver for MIL-STD-1553

April 16, 2007



FEATURES

- Dual transceiver meets military data bus requirements – MIL-STD-1553
- Low standby power
- Low power dissipation at full output power
- Single +5V power supply
- +5V Control line
- Current source output
- 0.3" x 1.2", ceramic, 18 lead DIP or flat package
- Designed for commercial, industrial and aerospace applications
- Processed and screened to MIL-STD-883 specifications
- Aeroflex is a Class H & K MIL-PRF-38534 Manufacturer
- DESC SMD pending



GENERAL DESCRIPTION

The Aeroflex Plainview model ACT4419D is a monolithic transceiver which provides variable amplitude in full compliance with MIL-STD-1553 data bus requirements with low standby power consumption and one power supply operation.

The dual channel model ACT4419D performs the front-end analog function of inputting and outputting data through a transformer to a MIL-STD-1553 data bus.

Design of these transceivers reflects particular attention to active filter performance. This results in low bit and word error rate with superior waveform purity and minimal zero crossover distortion. Efficient transmitter electrical and thermal design provides low internal power dissipation and heat rise at high as well as low duty cycles.

Variable amplitude is adjusted with factory preset 0 – 5 Vdc control line at 1 mA maximum input current at 5 Volts.

TRANSMITTER

The Transmitter section accepts bi-phase TTL data at the input and when coupled to the data bus with a primary grounded center tap 1:2.5 transformer the data bus signal produced is 7.1 Volts nominal P-P at A-A' (See Figure 5). When both DATA and $\overline{\text{DATA}}$ inputs are held low, the transmitter output becomes a high impedance and is "removed" from the line. In addition, an overriding "INHIBIT" input provides for the removal of the transmitter output from the line. A logic "1" applied to the "INHIBIT" takes priority over the condition of the data inputs and disables the transmitter. (See Transmitter Logic Waveform, Figure 1).

The transceiver utilizes an active filter to suppress harmonics above 1MHz. The Transmitter may be safely operated at 100% duty cycle for an indefinite period into a short circuited 1553 bus.

RECEIVER

The Receiver section accepts bi-phase differential data at the input and produces two TTL signals at the output. The outputs are DATA and $\overline{\text{DATA}}$, and represent positive and negative excursions of the input beyond a pre-determined threshold. (See Receiver Logic Waveform, Figure 2).

The pre-set internal thresholds will detect data bus signals exceeding 1.150 Volts P-P and reject signals less than 0.6 Volts P-P when used with a 1:2.5 turns ratio transformer. (See transformer data and typical connection, Figure 5).

A low level at the Strobe input inhibits the DATA and $\overline{\text{DATA}}$ outputs.

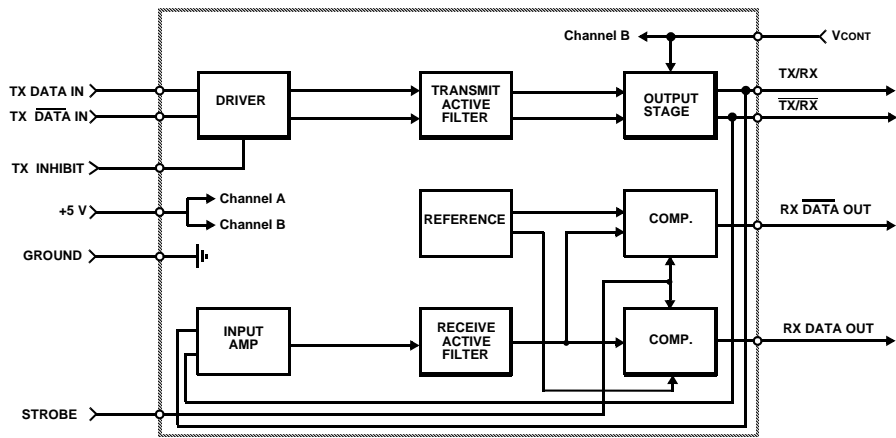

BLOCK DIAGRAM (WITHOUT TRANSFORMER, CHANNEL A SHOWN)

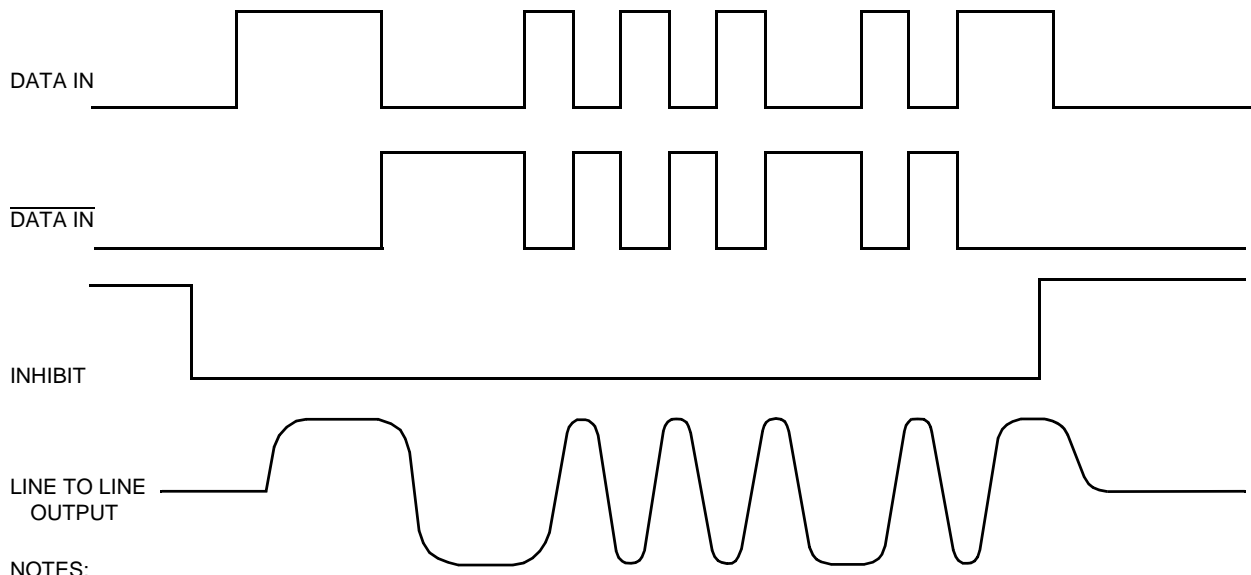

NOTES:

1. DATA and $\overline{\text{DATA}}$ inputs must be complementary waveforms or 50% duty cycle average, with no delays between them.
2. DATA and $\overline{\text{DATA}}$ must be in the same state during off time (both low).

FIGURE 1 - TRANSMITTER LOGIC WAVEFORMS

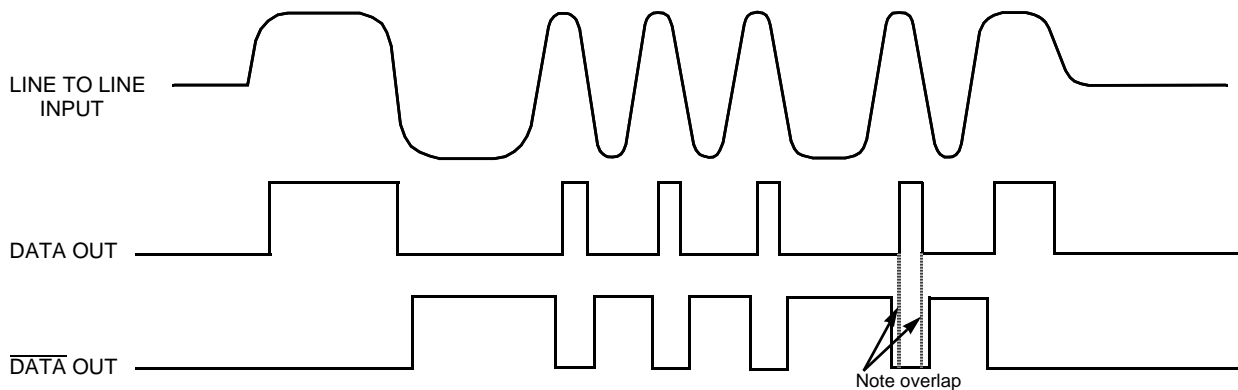

FIGURE 2 - RECEIVER LOGIC WAVEFORMS

ABSOLUTE MAXIMUM RATINGS

Operating Case Temperature	-55°C to +125°C
Storage Case Temperature	-65°C to +150°C
Positive Power Supply Voltage	+5.0 V to +7.0 V
Receiver Differential Input	±10 V
Receiver Input Voltage (Common Mode)	±5 V
Driver Peak Output Current	650 mA
Total Package Power Dissipation over the Full Operating Case Temperature Rise	2 Watt (Note: Normal operation conditions require one transmitter on and the other off at any given time)
Maximum Junction to Case Temperature	10°C
Thermal Resistance – Junction to Case	5°C/W

ELECTRICAL CHARACTERISTICS – DRIVER SECTION 1/ 3/

INPUT CHARACTERISTICS, TX DATA IN OR TX DATA IN

Parameter	Condition	Symbol	Min	Typ	Max	Unit
"0" Input Current	V _{IN} = 0.4 V	I _{ILD}	-	-0.2	-0.4	mA
"1" Input Current	V _{IN} = 2.7 V	I _{IHD}	-	1	40	μA
"0" Input Voltage	-	V _{ILD}	-	-	0.7	V
"1" Input Voltage	-	V _{IHD}	2.0	-	-	V

INHIBIT CHARACTERISTICS

"0" Input Current	V _{IN} = 0.4V	I _{ILI}	-	-0.2	-0.4	mA
"1" Input Current	V _{IN} = 2.7V	I _{IHI}	-	1.0	40	μA
"0" Input Voltage	-	V _{ILI}	-	-	0.7	V
"1" Input Voltage	-	V _{IHI}	2	-	-	V
Delay from TX inhibit,(0→1) to inhibited output	-	t _{DXOFF}	-	200	300	nS
Delay from TX inhibit, (1→0) to active output	-	t _{DXON}	-	100	180	nS
Differential Output Noise, inhibit mode	-	V _{NOI}	-	2	10	mVp-p
Differential Output Impedance * <u>2/</u>	-	Z _{OI}	2K	-	-	Ω

* See Aeroflex Application note# 113 for reference.

OUTPUT CHARACTERISTICS

Differential output level (direct coupled stub)	Pt. A - A'	V _O	6.6	7.1	7.6	V p-p
Differential output level (transformer coupled)	Pt. B - B'	V _O	18.7	20.1	21.5	V p-p
Rise and Fall times	-	t _R & t _F	100	170	300	nS
Output Offset <u>4/</u>	Pt. A - A'	V _{OS}	-	-	±90	mV peak
Delay from 50% point of TX DATA or TX DATA input to zero crossing of differential signal	-	t _{DTX}	-	120	180	nS
Output Voltage Delta, Pt. A - A' <u>5/</u>	-	V _{OΔD}	0	±71	±142	mVp-p
Output Voltage Delta, Pt. B - B' <u>5/</u>	-	V _{OΔS}	0	±200	±400	mVp-p
Control Line Input Resistance	-	R _{CONT}	-	5	-	KΩ

ELECTRICAL CHARACTERISTICS – RECEIVER SECTION 1/3/

Parameter	Condition	Symbol	Min	Typ	Max	Unit
Differential Voltage Range	Point A - A'	VIDR	-		20	V peak
Common Mode Rejection Ratio	-	CMRR	45	-	-	dB

STROBE CHARACTERISTICS (Logic "0" Inhibits Output)

"0" Input Current	V _S = 0.4 V	I _{IL}	-	-0.2	-0.4	mA
"1" Input Current	V _S = 2.7V	I _{IH}	-	1	+40	μA
"0" Input Voltage	-	V _{IL}	-	-	0.7	V
"1" Input Voltage	-	V _{IH}	2.0	-	-	V
Strobe Delay (turn-on)	-	t _{SD(ON)}	-	90	150	nS
Strobe Delay (turn-off)	-	t _{SD(OFF)}	-	90	150	nS

THRESHOLD CHARACTERISTICS (Sinewave Input)

Input Threshold Voltage(referred to the bus)	100KHz-1MHz	V _{TH}	0.60	0.8	1.15	Vp-p
--	-------------	-----------------	------	-----	------	------

OUTPUT CHARACTERISTICS, RX DATA AND RX DATA

"1" State	I _{OH} = -0.4 mA	V _{OH}	2.5	3.5	-	V
"0" State	I _{OL} = 4 mA	V _{OL}	-	0.3	0.5	V
Delay, (average)from differential input zero crossings to RX DATA and RX DATA output 50% points	-	t _{DRX}	-	320	400	nS

POWER DATA 1/3/

MAXIMUM CURRENT PER CHANNEL (Other channel in standby)

Duty Cycle	Typ	Max
Transmitter Standby	50 mA _t	65 mA
25% duty cycle	155 mA	185 mA
50% duty cycle	290 mA	335 mA
100% duty cycle	560 mA	650 mA

+V	4.75 to 5.5 Volts
----	-------------------

- Notes: 1. V_{CC} = 5 Volts ±0.1 V, T_C = -55°C to +125°C, unless otherwise specified.
 2. Power ON/OFF, measured from 75KHz to 1MHz at Point A-A'. See Figure 5.
 3. All typical values are measured at +25°C.
 4. At point A-A' on Figure 5, 2.5 μS after midpoint crossing of the parity bit of the last word of a 660 μS message.
 5. Output Voltage Delta (ΔV_O) = V_{O(IDEAL)} - V_{O(MEASURED)}, where V_{O(IDEAL)} = Slope x V_{CONT} and Slope = ΔV_O ÷ ΔV_{CONT}, See Figure 3.

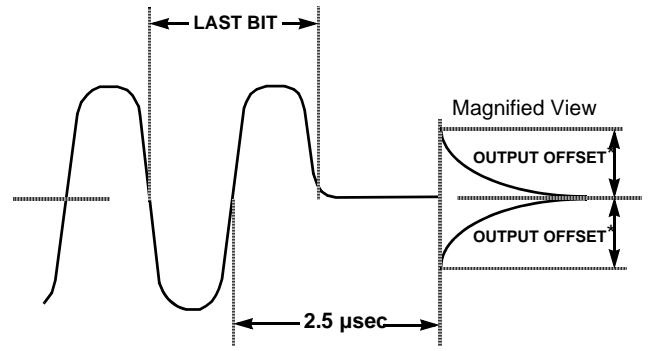
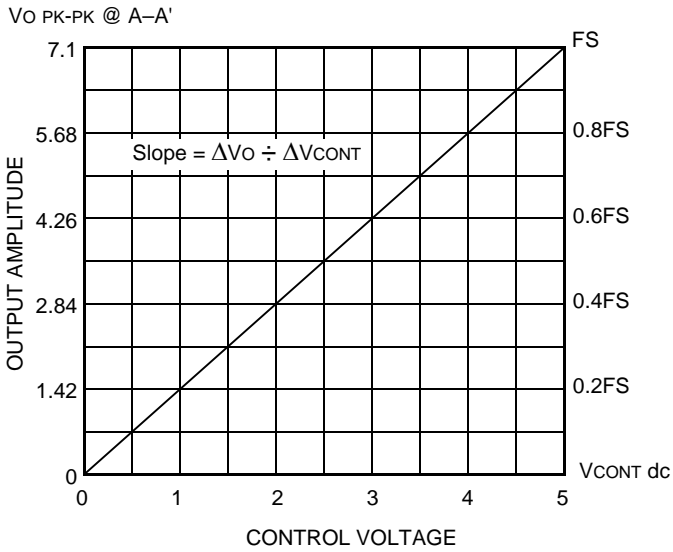

*Offset measured at point A-A' in Figure 5

FIGURE 3 – TRANSMITTER OUTPUT AMPLITUDE (Vo) vs. VCONT VOLTAGE

FIGURE 4 – TRANSMITTER (TX) OUTPUT OFFSET

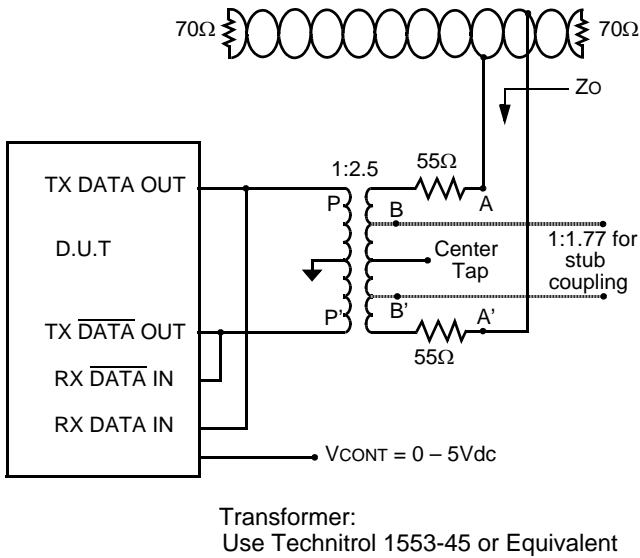
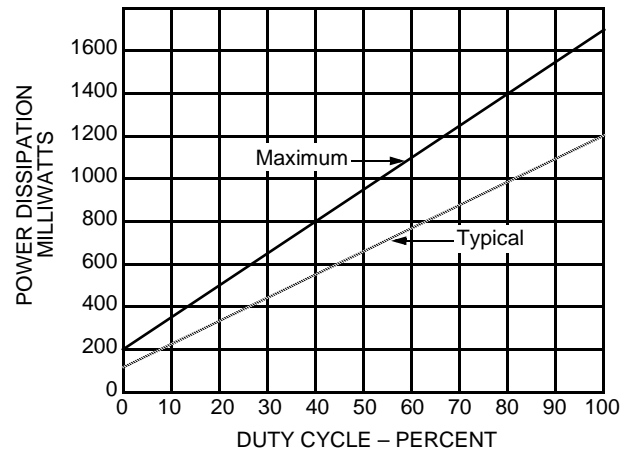

FIGURE 5 – TYPICAL TRANSFORMER CONNECTION



Note: Vcc = 5 Volts, Vbus (Pt. A-A') at 7.1 Volts P-P

FIGURE 6 – POWER DISSIPATION vs. DUTY CYCLE (Total hybrid with one channel transmitting and the other in standby)

PACKAGE PIN OUT DESCRIPTION - ACT4419D

Pin #	Function	Pin #	Function
1	VCONT A & B (0 – 5Vdc)	11	RX $\overline{\text{DATA}}$ OUT B
2	TX/RX A	12	RX DATA OUT B
3	$\overline{\text{TX/RX}}$ A	13	TX INHIBIT B
4	STROBE A	14	TX DATA IN B
5	GROUND A	15	TX $\overline{\text{DATA}}$ IN B
6	+5Vdc A & B	16	RX $\overline{\text{DATA}}$ OUT A
7	TX/RX B	17	RX DATA OUT A
8	$\overline{\text{TX/RX}}$ B	18	TX INHIBIT A
9	STROBE B	19	TX DATA IN A
10	GROUND B	20	TX $\overline{\text{DATA}}$ IN A

PACKAGE DIMENSIONS

FLAT PACKAGE

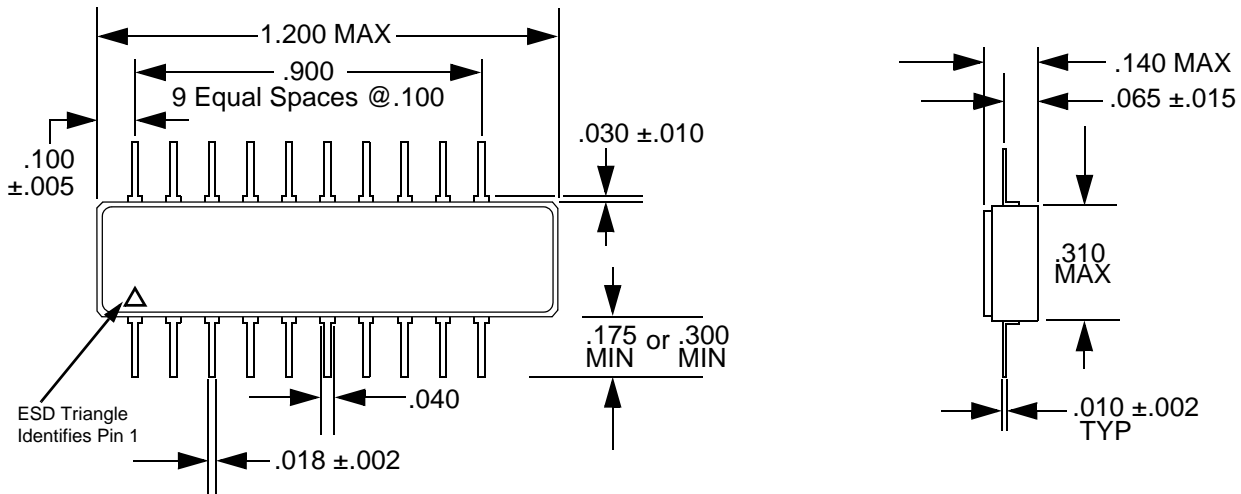

DIP PACKAGE

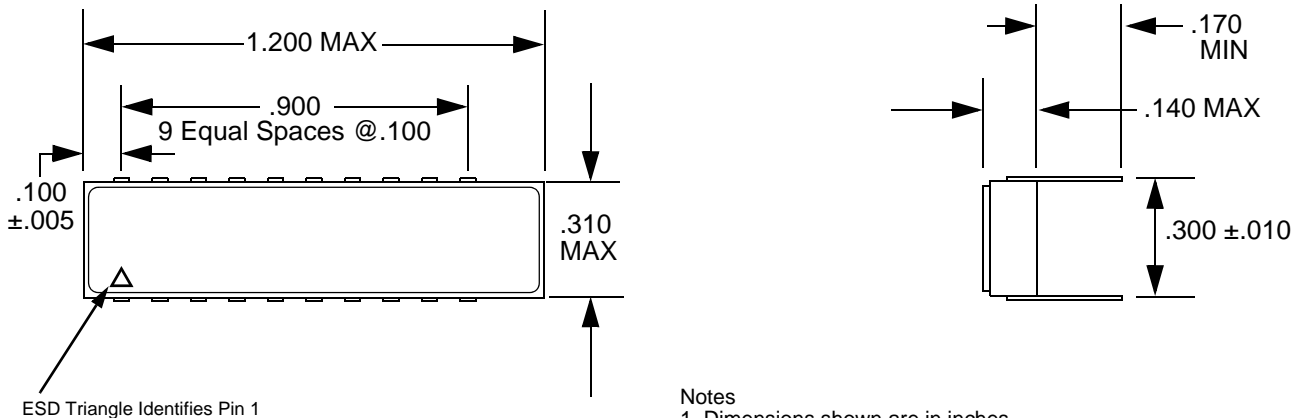

Notes
1. Dimensions shown are in inches

CONFIGURATIONS AND ORDERING INFORMATION

Model No.	DSCC No.	Receiver Data level	Case	Lead Finish
ACT4419-D *	N/A	Normally Low	DIP	Optional
ACT4419-D-001-1	Pending			Gold
ACT4419-D-001-2	Pending			Solder
ACT4419-DF *	N/A		Flat Pack	Optional
ACT4419-D-001-1	Pending			Gold
ACT4419-D-001-2	Pending			Solder

* For 10V Control voltage consult factory.

PLAINVIEW, NEW YORK
Toll Free: 800-THE-1553
Fax: 516-694-6715

INTERNATIONAL
Tel: 805-778-9229
Fax: 805-778-1980

NORTHEAST
Tel: 603-888-3975
Fax: 603-888-4585

SE AND MID-ATLANTIC
Tel: 321-951-4164
Fax: 321-951-4254

WEST COAST
Tel: 949-362-2260
Fax: 949-362-2266

CENTRAL
Tel: 719-594-8017
Fax: 719-594-8468

www.aeroflex.com info-ams@aeroflex.com



Aeroflex Microelectronic Solutions reserves the right to change at any time without notice the specifications, design, function, or form of its products described herein. All parameters must be validated for each customer's application by engineering. No liability is assumed as a result of use of this product. No patent licenses are implied.



Our passion for performance is defined by three attributes represented by these three icons: solution-minded, performance-driven and customer-focused