



A Logical Interface for Integrating and Controlling Electromechanical Devices and Subsystems.

By Jerry Messina & Barry Newlin

Weinschel's new SmartStep technology streamlines system designs and device integration by providing a flexible bus interface (Model 8210) as well as components that are simple to configure and control.

Weinschel's approach starts with the Model 8210 SmartStep Interface which provides a flexible, low cost solution for the control and operation of electromechanical switches and programmable step attenuators using standard communications interfaces. Designed to interface to a new line of SmartStep programmable attenuators, the 8210 represents a new concept in device control applications for bench test and subsystem designs. The Model 8210 provides a highlevel interface from various industry standard communications interfaces, including IEEE488 and RS232/RS422/RS485, to the SmartStep's serial Driver Interface Bus.

The Driver Interface Bus (DIB) is a system for connecting a number of relatively low speed I/O devices to a host, providing a simple, uniform, and inexpensive way to control a variety of devices via a single port. The DIB is based on the two-wire I2C serial bus and several software protocol layers that allow the SmartStep Interface to address up to 125 peripheral devices, with serial data rates of up to 100 KHz. The DIB may also be used to supply DC power to the devices, resulting in a simple, lowcost interconnection system.

The SmartStep Interface is available in several models, each providing a different type of communications interface to suit the user's configuration requirements. Each model contains similar capabilities, and provides switch selectable parameters to tailor the interfaces operation.

Applications

Applications for the 8210 range from providing control of a single SmartStep Attenuator in a bench test/lab environment using a PC and a terminal emulator, to complex system applications where the 8210 is employed to control many devices to create custom and semi-custom subsystems to reduce overall design cost. Weinschel can provide a variety of custom designed driver interfaces for various devices, such as RF switches, relays, pin attenuators, displays, and other devices, as well as complete subsystem design and integration services. This is the ideal solution for creating multi-path subsystems for use in specialized wireless communication test applications for Cellular, PCS, Modem, and CATV equipment and systems. Contact us with your specialized needs.

Plug & GO SmartStep Programmable Attenuators

This SmartStep approach also includes a new generation of

intelligent programmable step attenuators with a built-in digital interface. These Models are designed to simplify the control and integration of these devices into subsystem and bench applications.

The SmartStep attenuators feature a microcontrollerbased driver that provides a TTLlevel digital interface for control of the attenuator relays. This new feature simplifies operation

latching type which along with various jumper configurations, can be used with the 8210 to control a variety of devices such as RF Switches (+28V and latching) and other TTL compatible devices. This card also provides an optional three pin External Power connector which can be used to supply power to the device(s) under control, to simplify wiring.

software to control two separate devices, but also develop an algorithm for determining the appropriate settings for each device. In addition, if your requirements were to change perhaps to a larger attenuation range, or a different step size, these algorithms would have to change accordingly. The 8210 provides a solution to this dilemma with the ability to create and define a virtual device. A virtual device allows the user to construct a device by combining the attributes of several physical devices, and be able to program this combination as if it were one physical device! Revisiting our example above, we can create a virtual attenuator with an attenuation range of 81/1 dB steps, effectively creating a 150T-81. Controlling this new device requires no more programming than controlling a single attenuator.

The 8210 supports up to 32 virtual attenuator devices, each of which allow up to four physical attenuators to be combined into a single device. The virtual attenuator uses the Attn Protocol command set, providing the same programming interface as other attenuator devices. During the setup process, the user assigns a name to the virtual attenuator, which may be stored in the 8210's nonvolatile EEPROM memory for future use. During the power-up configuration process, the 8210 will automatically recall and assign these virtual devices.

Subsystems in Minutes....

Using the Smartstep approach a customer can easily design and layout subsystems in minutes that includes a wide range of Plug & GO programmable attenuators and other standard microwave and RF components which can be controlled over various standard communications interfaces, including IEEE-488, RS232, RS422, and RS485. For complex and specialized applications Weinschel offers subsystem design and manufacturing services to help you implement this new approach into your specific program.

Specific Driver Configurations can also be designed for operating your devices or retrofitting an existing device with the SmartStep Approach!

Conclusion

Weather you're designing your own switching/combining/attenuation wire simulation system or require a turnkey solution, contact Weinschel for a wide range of standard products or custom engineered subsystems at 800-638-2048, 301-831-4701 or email:sales@weinschel.com (www.weinschel.com)!
WEINSCHTEL CORP

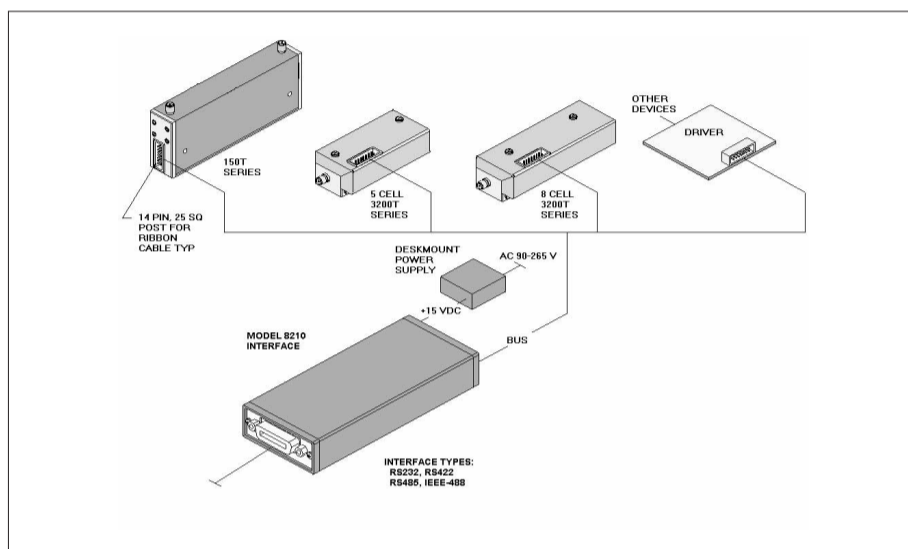

Figure 1. Model 8210 Applications

and interfacing requirements, while at the same time providing for greatly enhanced flexibility over past designs.

These SmartStep Devices contain nonvolatile configuration memory used to hold a wide variety of attenuator and driver dependent parameters, including serial number, attenuator cell dB values, relay configurations and switching requirements which are all accessible via the DIB.

Plug & GO SmartStep Switch/Relay Drivers

Standard as well as custom designed Switch/Relay Driver Cards are available for controlling a wide variety of electromechanical switches and other TTL devices. For example one of our standard designs contains eight electromechanical relays for output and control.

The relays are Form C (SPDT)

This External Power is not used by the control circuitry on the Relay Driver, and its use is completely application dependent.

Create Virtual Devices...

Sometimes, when constructing a system or subsystem, you cannot find a device that provides quite the functionality that you require. Assume you need a large attenuation range, but a small incremental step size. Typically, one would be forced to use two physical attenuators connected in series to achieve this goal. For example, let's assume there is a requirement for an attenuator with a total attenuation >80 dB, with a resolution of 1 dB over the dc-18 GHz frequency range. One could combine a Model 150T-70 (0-70/10 dB steps) with a Model 150T-11 (0-11/1 dB steps) to meet this goal. Unfortunately, the programming burden has increased dramatically, since you must now not only write the

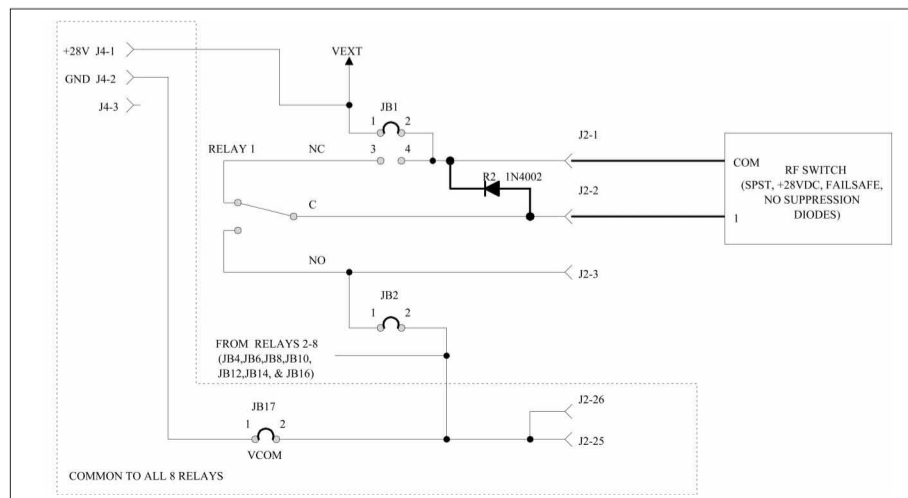

Figure 2. Typical SmartStep Relay Driver Setup