

Broadband Standard Product PA020180-3025-SS High Power Amplifier Module Broadband Power 2GHz to 18GHz

March 31, 2006

www.aeroflex.com/bband



DESCRIPTION

Our new innovative broadband power amplifier designs provide performance without sacrificing output power. The ultra wideband performance of the PA020180-3025-SS can replace multiple narrowband power amplifiers, there by reducing cost and complexity in microwave systems.

Our team of engineers can custom design power amplifiers using the latest simulation software and proprietary technology to meet even the most demanding specifications.

FEATURES

- >30dBm P1 dB up to 18GHz
- 30dB Typical Gain
- 7dB NF @ 16GHz (Typical)
- IP3 >40dBm @ 8GHz
- Single Power Supply
- High Efficiency
- Compact Size

SPECIFICATIONS

ABSOLUTE MAXIMUM RATINGS¹

PARAMETER	SYMBOL	MIN	MAX	UNITS
Operating Temperature – Case	T _{MO}	-40	+65	°C
Storage Temperature – Case	T _{MS}	-40	+125	°C
Positive Supply Voltage	V _{PS}	+12	+15	V

1. Stresses above those listed under "Absolute Maximums Rating" may cause permanent damage to the device. This is a stress rating only and functional operation of the device at these or any other conditions above those indicated in the operational sections of this specification is not implied. Exposure to absolute maximum rating conditions for extended periods may affect device reliability.

NOMINAL OPERATING CONDITIONS

PARAMETER	CONDITIONS	MIN	MAX	UNITS
Temperature, T _O	Full Range	-40	+55	°C
Positive Supply Voltage, V _{PS}		+12	+15	V

Aeroflex Plainview

SPECIFICATIONS

ELECTRICAL CHARACTERISTICS

PARAMETER	CONDITIONS	MIN	TYP	MAX	UNIT
Frequency Range		2.0	-	18	GHz
Power Output	1dB Compression Point	+30	+32	+33	dBm
Power Output Saturated	Saturated Power	+31	+33	+35	dBm
Gain		25	-	-	dB
Gain Flatness		-1.5	-	+1.5	dB
Noise Figure	@ 8GHz	-	6.5	-	dB
RF Input Return Loss	2- 18GHz, Reference to 50 ohms	-	-	10	dB
RF Output Return Loss	4- 18GHz, Reference to 50 ohms	-	-	10	dB
Positive Supply Voltage		+12	-	+15	V
Positive Supply Current +12V, +15V		-	-	2.4	Amps

TYPICAL S-PARAMETERS

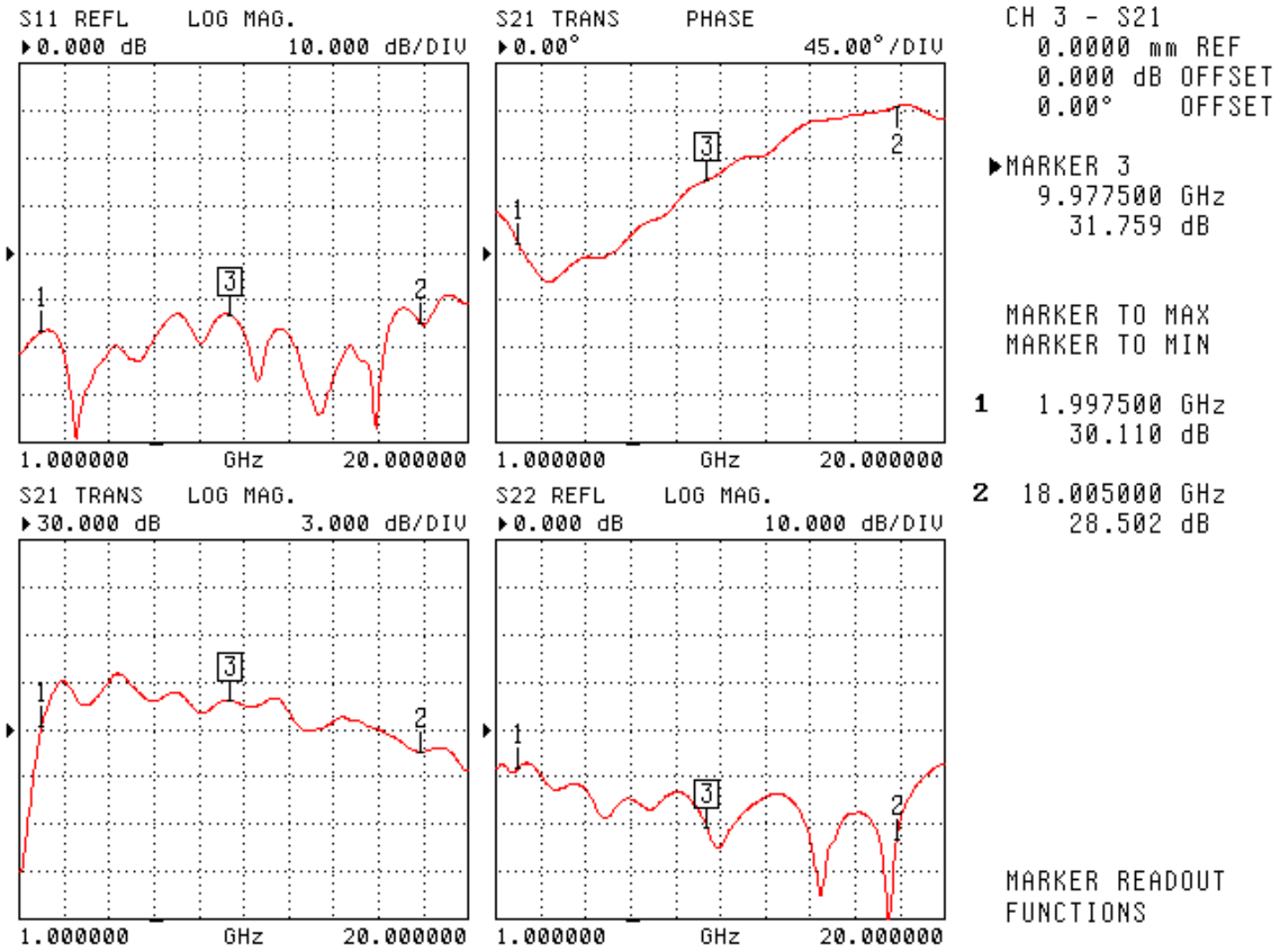

TYPICAL NOISE FIGURE

Agilent 15:24:52 Apr 6, 2005

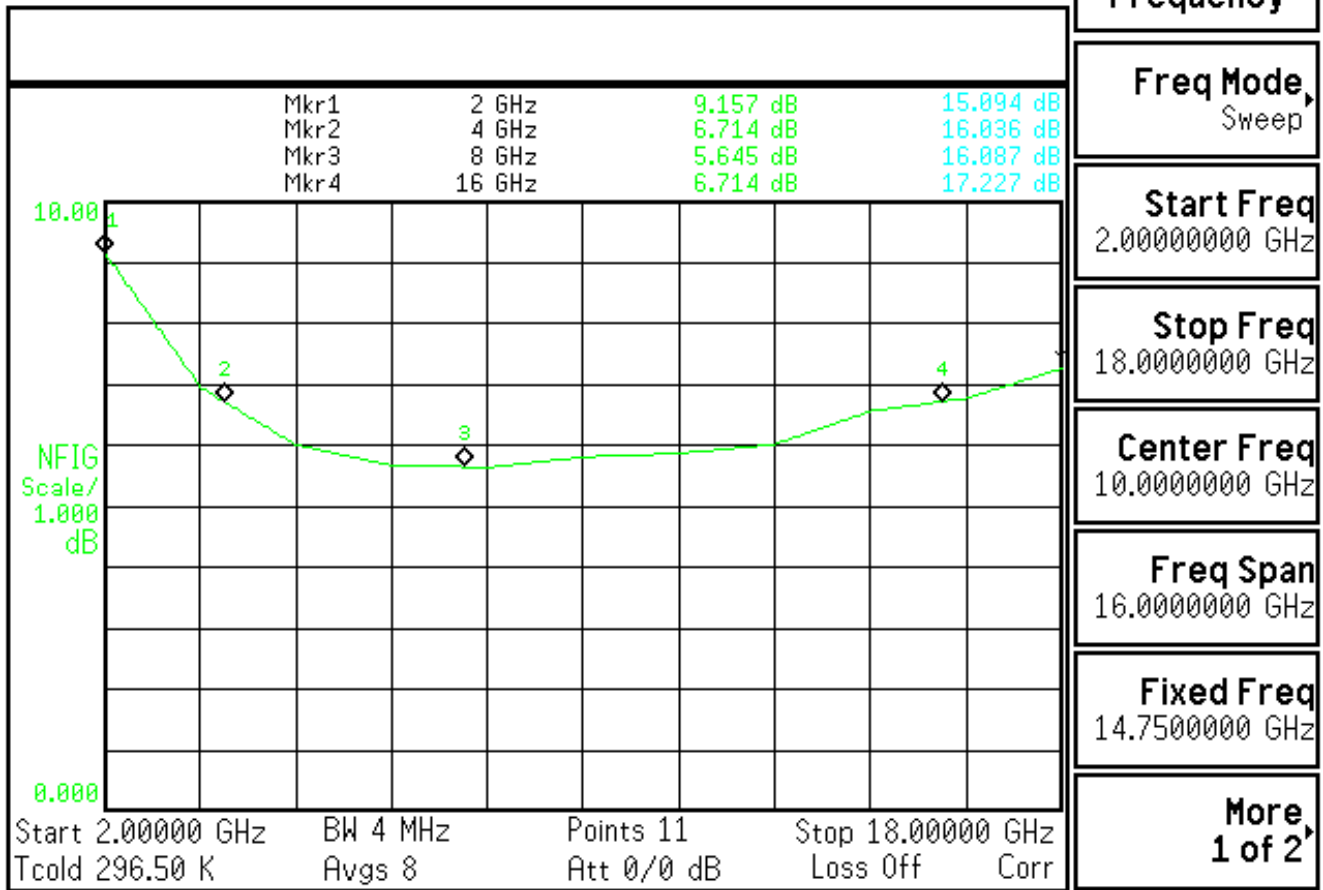

TYPICAL RF OUTPUT POWER

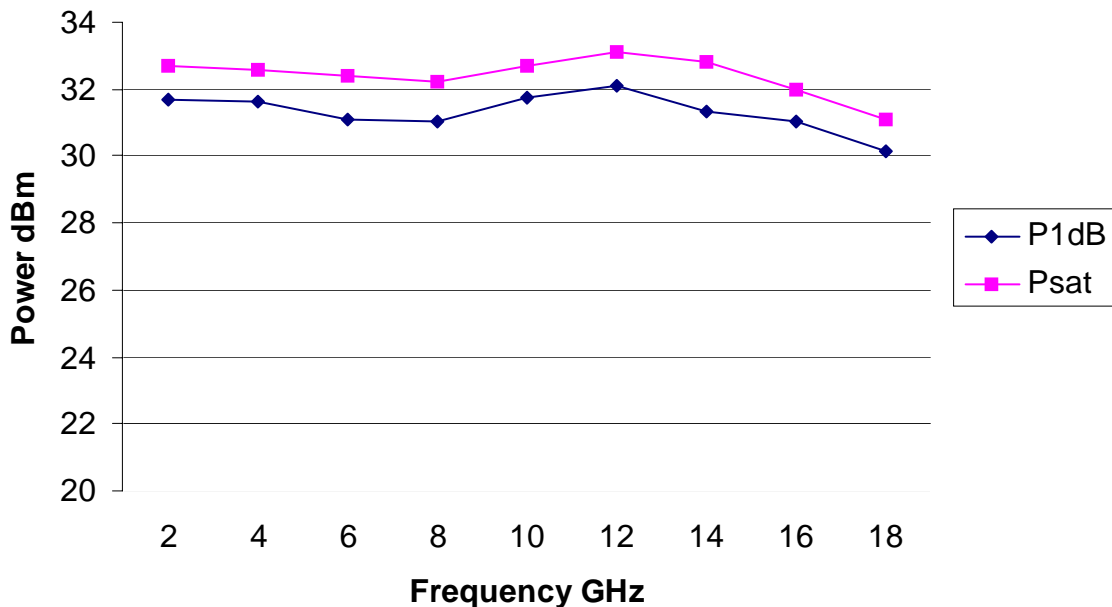

PHASE NOISE

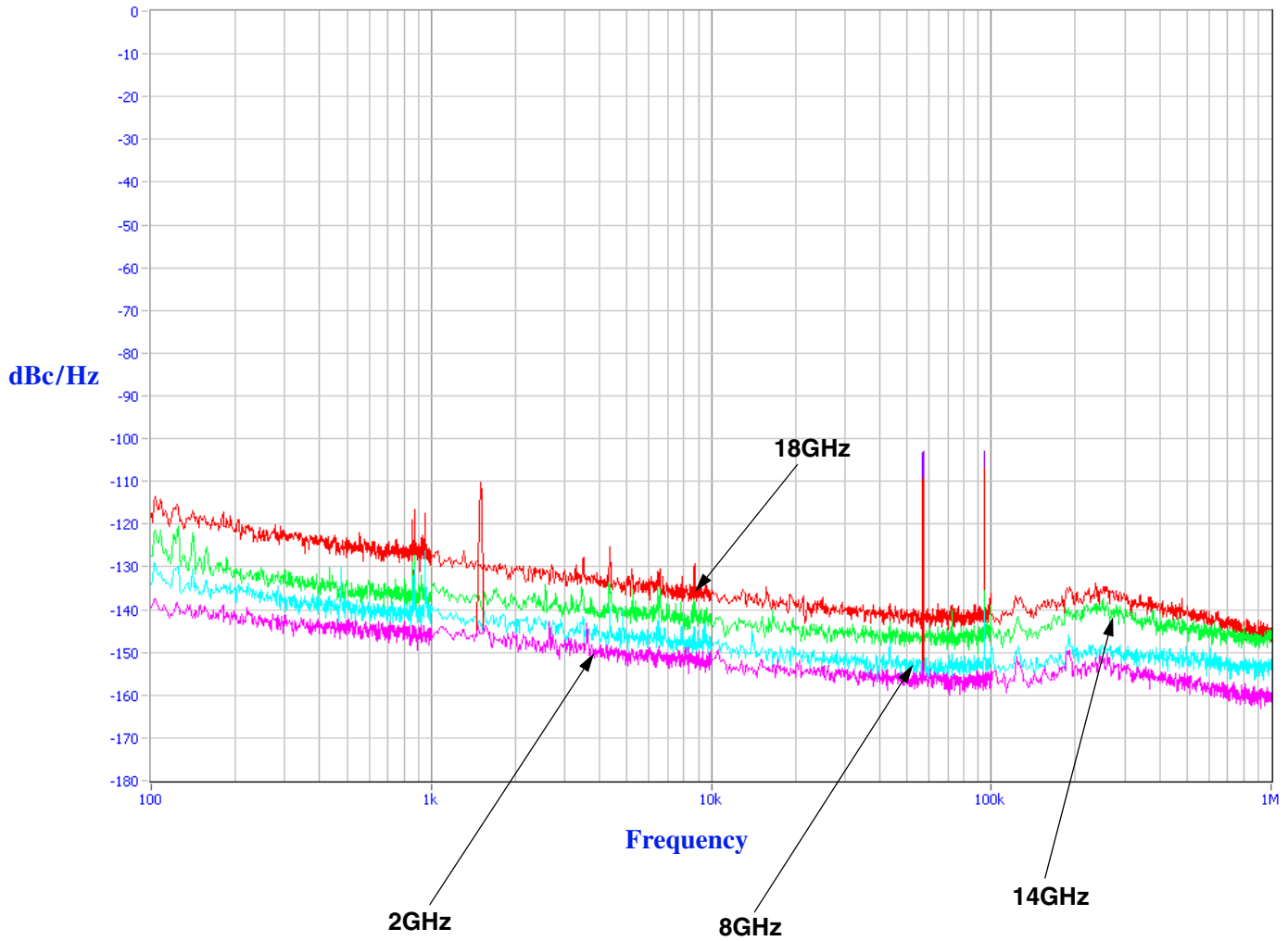

OUTLINE DRAWING

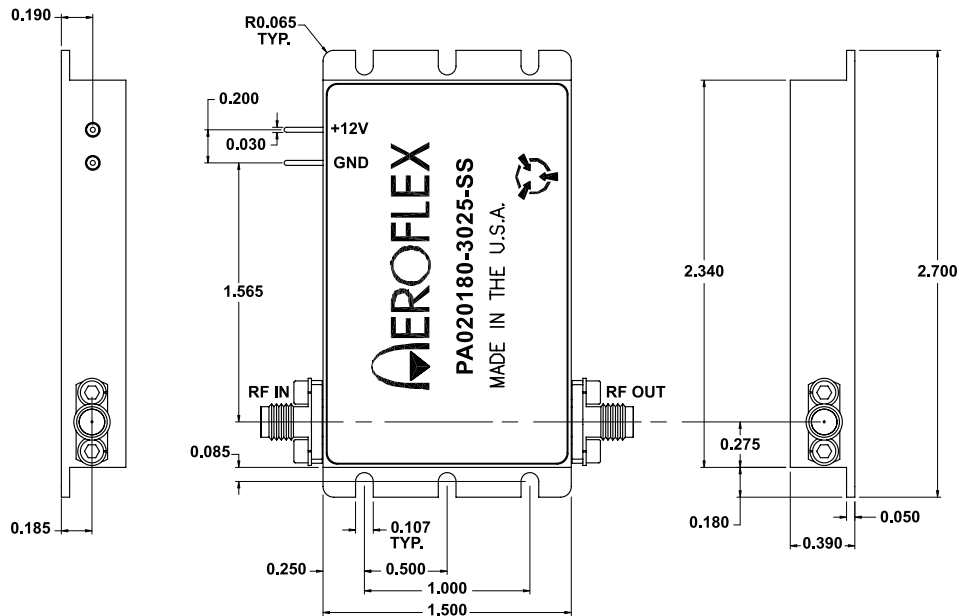

ISOMETRIC VIEW

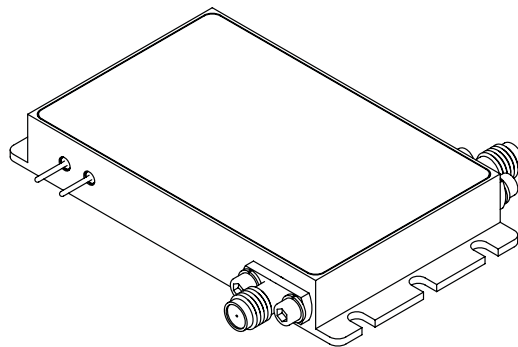

ORDERING INFORMATION

MODEL NUMBER	HERMETICITY	PACKAGE
PA020180-3025-SS	Non Hermetic	2.70L x 1.50W x .39Ht

PLAINVIEW, NEW YORK
Toll Free: 800-THE-1553
Fax: 516-694-6715

INTERNATIONAL
Tel: 805-778-9229
Fax: 805-778-1980

NORTHEAST
Tel: 603-888-3975
Fax: 603-888-4585

SE AND MID-ATLANTIC
Tel: 321-951-4164
Fax: 321-951-4254

WEST COAST
Tel: 949-362-2260
Fax: 949-362-2266

CENTRAL
Tel: 719-594-8017
Fax: 719-594-8468

www.aeroflex.com info-ams@aeroflex.com

Aeroflex Microelectronic Solutions reserves the right to change at any time without notice the specifications, design, function, or form of its products described herein. All parameters must be validated for each customer's application by engineering. No liability is assumed as a result of use of this product. No patent licenses are implied.



Our passion for performance is defined by three attributes represented by these three icons: solution-minded, performance-driven and customer-focused