

INSTALLATION & OPERATING INSTRUCTIONS

Models 153 Programmable Step Attenuator



This documentation may not be reproduced in any form, for any purpose unless authorized in writing by Aeroflex / Weinschel, Inc..



© Aeroflex / Weinschel, Inc.
Frederick, Maryland
2006

GENERAL

This manual provides general installation instructions and wiring data to be used as an aid in installing a Aeroflex / Weinschel 153 Series Programmable Step Attenuator into any system or application. Also included are specifications and other technical data to help in the installation and operation of the 153 Series Programmable Attenuator.



This series of Programmable Step Attenuators provide attenuation from 0-70 dB or 0-110 dB in 10 dB steps. These attenuators provide programmable adjustments of RF signal levels in precise steps of 10 dB and consist of a cascaded assembly of switched attenuator cells (Figure 1). The attenuator elements located in the attenuator cell are created by a thin-film process which provides exceptional long-term stability, low power and temperature coefficients. This series uses a reed switching structure that provides rapid switching together with low insertion loss. The 153 series is available in three cell (153-70) and four cell (153-110) configurations.

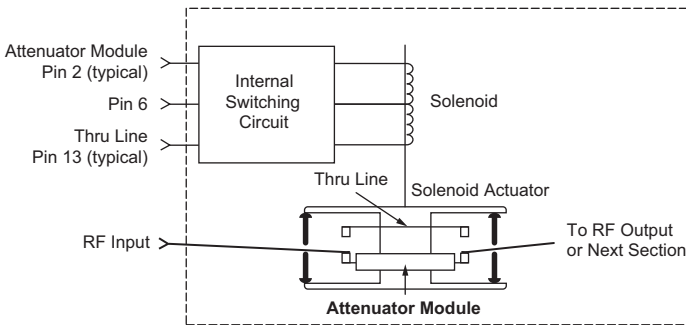

Figure 1. Cell Schematic

All models use in-line, female 2.92mm Connectors and contain a 14 pin Dip control connector that is plug-compatible with other competitive units.

INSTALLATION



CAUTION

Avoid Mechanical Shock. RF components are designed to withstand years of normal bench handling. However, do not drop or otherwise treat them roughly. They are laboratory-quality devices and, like other such devices, require careful handling.

MOUNTING: Each Programmable Step Attenuator is supplied with two mounting screws (P/N MS35335-57). These screws will fit any of the mounting holes (4-40 UNC-2B x 0.22 MIN DP) located on either side of the attenuator.



CAUTION

Avoid Over Torquing Connectors: Over torquing connectors is destructive; it may damage the mating surface of the outer conductor. This can change the pin depth and may damage the center pin. Proper torque for 2.92mm connector is 5 inch pounds. Never use pliers to tighten connectors.

Keep Step Attenuator Connectors Clean: The precise geometry that makes the RF component's high performance possible can be easily disturbed by dirt and other contamination adhering to connector interfaces. When not in use, keep the connectors covered.

RF CABLE INSTALLATION: Care should be taken to prevent strain on the interconnecting cables, since damage here may not always be apparent. Check the attaching RF cables and the 2.92mm (SMK) connectors for signs of cracked insulation and/or bent or worn pins prior to connection. Tests show that connectors must be clean for accuracy and stability. This requires an inspection and cleaning of each connector immediately before use. When cleaning precautions are observed regularly, connectors can maintain their stability for over several thousand connection cycles. Aeroflex / Weinschel recommends a torque value of 5 inch pounds when connecting any RF cable to the attenuator's RF connectors.

CONTROL CONNECTOR WIRING: The table below provides the necessary wiring data to connect the attenuator to the appropriate driver circuitry. This table covers both types of attenuator cables. The figure is also provided to show the location of each control connector pin.

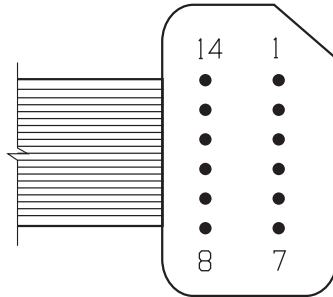



Table 1. Pin Assignments for DIP Connector

Pin Number	Wire Color	153-70	153-110
1	---	---	---
2	White	10 dB Cell Attenuator	10 dB Cell Attenuator
3	Violet	40 dB Cell Thru Line	40 dB Cell 1 Thru Line
	Green	---	40 dB Cell 2 Thru Line
	Orange	20 dB Cell Attenuator	20 dB Cell Attenuator
6	Brown	+24Vdc	+24Vdc
7	---	---	---
8	---	---	---
9	Red	40 dB Cell Attenuator	40 dB Cell 1 Attenuator
10	Yellow	---	40 dB Cell 2 Attenuator
11	Blue	20 dB Cell Thru Line	20 dB Cell Thru Line
12	Grey	---	---
13	Black	10 dB Cell Thru Line	10 dB Cell Thru Line
14	---	---	---

Note: Since the DIP connector pin assignments are identical to those used by other manufacturers, the Aeroflex / Weinschel attenuators can be substituted in existing system designs.

SPECIFICATIONS

NOMINAL IMPEDANCE: 50 Ω

FREQUENCY RANGE: dc to 40 GHz

MAXIMUM INSERTION LOSS (dB):

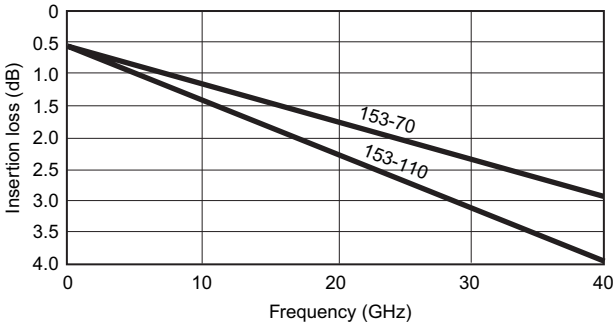

ATTENUATOR ACCURACY (\pm dB):

Frequency Range (GHz)	Attenuation (dB)							
	10	20	30	40	50	60	70	80-110
DC - 8	0.3	0.5	0.6	0.7	0.8	1.0	1.1	1.4
8 - 12	0.4	0.5	0.7	0.9	1.0	1.3	1.5	2.0
12 - 20	0.5	0.6	0.8	1.1	1.2	1.4	1.7	2.2
20 - 26.5	0.7	0.8	1.0	1.5	1.6	1.9	2.3	2.8
26.5 - 40	0.9	1.0	1.2	1.7	1.9	2.3	2.6	3.2

SWITCHING SPEED: 20 msec. maximum

OPERATING VOLTAGE: +24V nominal, +20V minimum; +30V maximum

SWITCHING CONTROL CURRENT: 125 mA typical per cell @ +24V nominal, Model 153-70 has 3 cells and 153-110 has 4 cells

SOLENOID COIL IMPEDANCE: 190 Ω

SOLENOID COIL INDUCTANCE: 65 mH

POWER RATING: 1 watt average, 100 watts peak
(5 μ sec pulse width, 0.5% duty cycle)

RF POWER SENSITIVITY: 0.001 dB/dB/W

SWITCH LIFE: 5 million (minimum operations per cell)

REPEATABILITY:

- \pm 0.03 dB to 18 GHz
- \pm 0.05 dB to 26.5 GHz
- \pm 0.08 dB to 40 GHz

TEMPERATURE RANGE:

- Operating: -0°C to $+70^{\circ}\text{C}$
- Non-Operating): -55°C to $+85^{\circ}\text{C}$

ALTITUDE: Operating: 4.6 km (440 mm Hg)
 Non-operating: 15 km

SHOCK: Operating: 10g, 6 ms, on 6 sides, 3 blows
 Non-operating: 500 g, 1.8 ms, in 6 directions

HUMIDITY: 0 to 95% relative humidity

EMC: MIL-STD-461, Method RE02, VDE 0871, CISPR#2

TEST DATA: Test data is available at additional cost.

CONNECTORS: 2.92mm connectors - mate nondestructively with SMA connectors per MIL-C-39012, 3.5mm, SMK, and other 2.92mm connectors.

CONTROL CONNECTOR: Standard 14 pin Dip

PROGRAMMING CABLE LENGTH: 406 mm(16 in.)

WEIGHT (Typical): 153-70: 170 g (3.5 oz)
 153-110: 213 g (4.8 oz)

PHYSICAL DIMENSIONS:

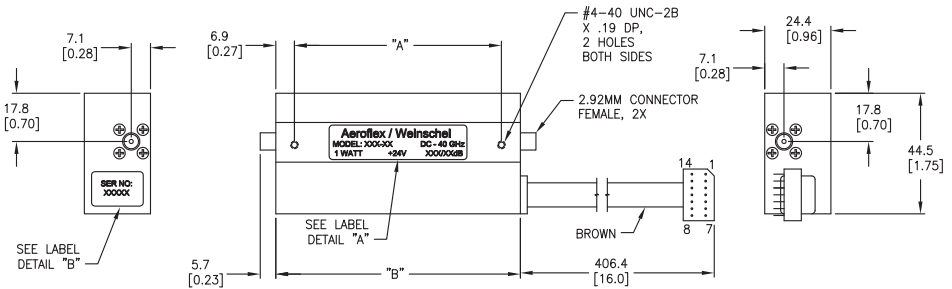

Model No.	No. Cells	A	B
153-70	3	76.2 (3.0)	90.2 (3.55)
153-110	4	102.9 (4.05)	115.8 (4.6)

NOTE: All dimensions are given in mm (inches) and are nominal, unless otherwise specified.

Aeroflex / Weinschel Warranty

PRODUCTS: Aeroflex / Weinschel warrants each product it manufactures to be free from defects in material and workmanship under normal use and service anywhere in the world. Aeroflex / Weinschel's only obligation under this Warranty is to repair or replace, at its plant, any product or part thereof that is returned with transportation charges prepaid to Aeroflex / Weinschel by the original purchaser within ONE YEAR from the date of shipment.

The foregoing Warranty does not apply to, and in Aeroflex / Weinschel, Inc.'s sole opinion, products that have been subject to improper or inadequate maintenance, unauthorized modifications, misuse, or operation outside the environmental specifications for the product.

SOFTWARE PRODUCTS: Aeroflex / Weinschel software products are supplied without representation or Warranty of any kind. Aeroflex / Weinschel, therefore, assumes no responsibility and will not accept liability (consequential or otherwise) arising from the use of program materials, disk, or tape.

The Warranty period is controlled by the Warranty document furnished with each product and begins on the date of shipment. All Warranty returns must be authorized by Aeroflex / Weinschel prior to their return.

Aeroflex / Weinschel Quality System Certified to:



Certificate No. 289H

AEROFLEX WEINSCHTEL

5305 Spectrum Drive, Frederick, Maryland 21703-7362
TEL: (301) 846-9222, 800-638-2048, FAX: (301) 846-9116
Web: www.aeroflex-weinschel.com
e-mail: sales@aeroflex-weinschel.com