

PIN Diode Driver

MPD3T5N200-703 Series Datasheet



Features

- Higher Output Voltage and Higher Output Current PIN Diode Driver in Surface Mount Package
- Usable with MSW3200-320 Series High Power Switches.
- Operates from 2 Polarities: +5 V and (-15 V to -200 V)
- Higher Output Currents (-50 mA) for Lower Switch Loss and (+50 mA) for Higher Isolation
- Multiple TTL Input Control, 3 Pairs of Complementary Outputs
- RoHS Compliant

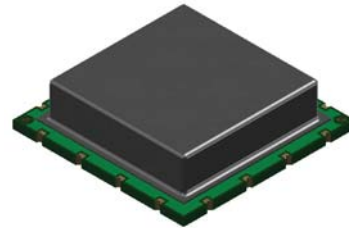

Description

The MPD3T5N200-703 Series of Surface Mount PIN Diode Drivers is designed to provide higher voltage and higher current operation for higher power PIN Diode Switches. In particular, these PIN Diode Drivers are intended to operate with Aeroflex/Metelics MSW3200 Series of Surface Mount, Higher Power SP3T Symmetrical Series-Shunt Switches.

These PIN Diode Drivers operate from +5 V and -15 V to -200 V DC power supplies to successfully operate the SP2T PIN Diode Switches from 20 – 6,000 MHz for 100 W C.W. or peak power levels. In addition, the Driver can supply current of -50 mA from the -200V supply to provide lower insertion loss and better high signal linearity to the Series PIN Diode. Multiple TTL control is available in the design. The Driver provides 3 pairs of complementary outputs that drive the bias ports in the SP3T PIN diode Switch. Propagation Delay (50 % TTL-10% RF Voltage) is on the order of 1 μ s and can be improved with external RC, current spiking network.

The PIN Diode Driver is designed in a 1.3 " square x 0.33 " H (33 mm sq x 8.4 mm H) surface mount package. The devices are available in tube and tape-reel packaging for high volume pick and place automated assembly and are RoHS compliant.

Applications

The MPD3T5N200-703 Driver Series is designed to be used in higher voltage and higher current PIN Diode switch applications, operating from 20 MHz to 6 GHz, requiring high volume, surface mount, solder re-flow manufacturing. These products are durable, reliable, and capable of meeting all military, commercial, and industrial environments.

Environmental Capabilities

The MPD3T5N200-703 Driver Series is capable of meeting the environmental requirements of MIL-STD-202 and MIL-STD-750.

ESD and Moisture Sensitivity Level Rating

Semiconductor Devices are susceptible to ESD conditions and environments. The ESD rating for this device is Class 1A, HBM. The moisture sensitivity level rating for this device is MSL 1.



MPD3T5N200-703 Electrical Specifications @ $T_A = +25\text{ }^\circ\text{C}$ (Unless Otherwise Defined)

Parameter	Symbol	Units	Test Conditions	Minimum Value	Typical Value	Maximum Value
Operating Frequency (PRF)	F	kHz	$+V_{CC} = +5\text{V}$, $-V_{EE} = -15\text{ V to }-200\text{ V}$	DC	0 – 100	500
Input Voltage 1	$+V_{CC}$	V	$+V_{CC} = +5\text{V}$, $-V_{EE} = -15\text{ V to }-200\text{ V}$	+4.5	+5.0	+5.5
Input Voltage 2	$-V_{EE}$	V	$+V_{CC} = +5\text{V}$, $-V_{EE} = -15\text{ V to }-200\text{ V}$	-15	-50	-200
$+V_{CC}$ Input Quiescent Current	$+I_{Q1}$	mA	$+V_{CC} = +5\text{V}$, $-V_{EE} = -15\text{ V to }-200\text{ V}$ $V_{out1} = V_{out2} = \infty\Omega$	10	20	30
$-V_{EE}$ Input Quiescent Current	$+I_{Q2}$	mA	$+V_{CC} = +5\text{V}$, $-V_{EE} = -15\text{ V to }-200\text{ V}$ $V_{out1} = V_{out2} = \infty\Omega$	-15	-25	-40
TTL Input Voltage, CTL 1	VTTL	V	Logic 0 @ 20 μA sink current Logic 1 @ 0.5 mA source current	0.0 2.0		0.8 5.0
Low Level Output Voltage @ V1a, V1b, V2a, V2b, V3a, V3b	V_{outL}	V	$+V_{CC} = +5\text{V}$, $-V_{EE} = -15\text{ V to }-200\text{ V}$ Current from $+V_{CC} = +50\text{ mA}$	$+V_{CC}-$ 1.0 V	$+V_{CC}-$ 0.5 V	$+V_{CC}-$ 0.1 V
High Level Output Voltage @ V1a, V1b, V2a, V2b, V3a, V3b	V_{outH}	V	$+V_{CC} = +5\text{V}$, $-V_{EE} = -15\text{ V to }-200\text{ V}$ Current from $-V_{EE} = -50\text{ mA}$	$-V_{EE}+$ 0.1 V	$-V_{EE}+$ 0.5 V	$-V_{EE}+$ 1.0 V
Switching Speed (Note 1)	Ton Toff	μS	$+V_{CC} = +5\text{V}$, $-V_{EE} = -15\text{ V to }-200\text{ V}$, F = 10 kHz (50% TTL–10% or 90 % RF Output Voltage)		1.5	2.0

Notes:

- Switching Speed is measured using the Aeroflex/Metelics MSW3200-320 Symmetrical SP3T @ 2.5 GHz @ $+V_{CC} = +5\text{ V}$ & $-V_{EE} = -50\text{ V}$ in the commutating switching mode.

PIN Diode Driver

MPD3T5N200-703 PIN Diode Driver Schematic:

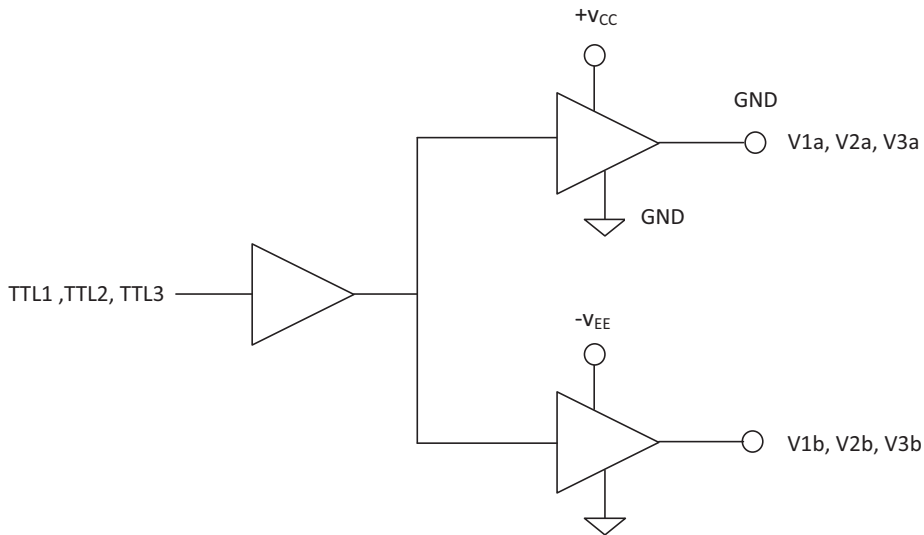

MPD3T5N200-703 PIN Diode Driver with an external RC Spiking Network:

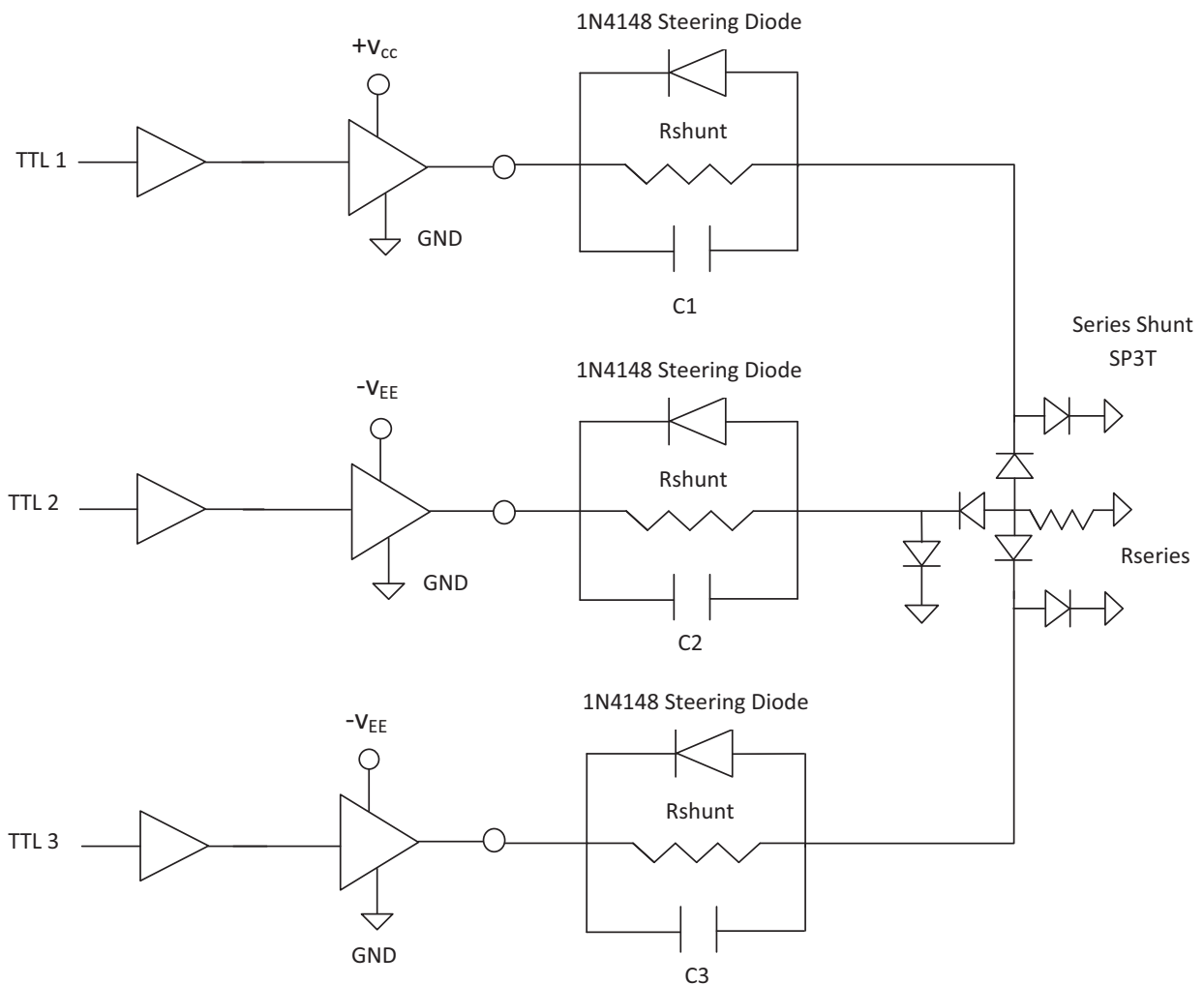

MPD3T5N200-703 PIN Diode Driver and Series-Shunt SP3T as DC Load:

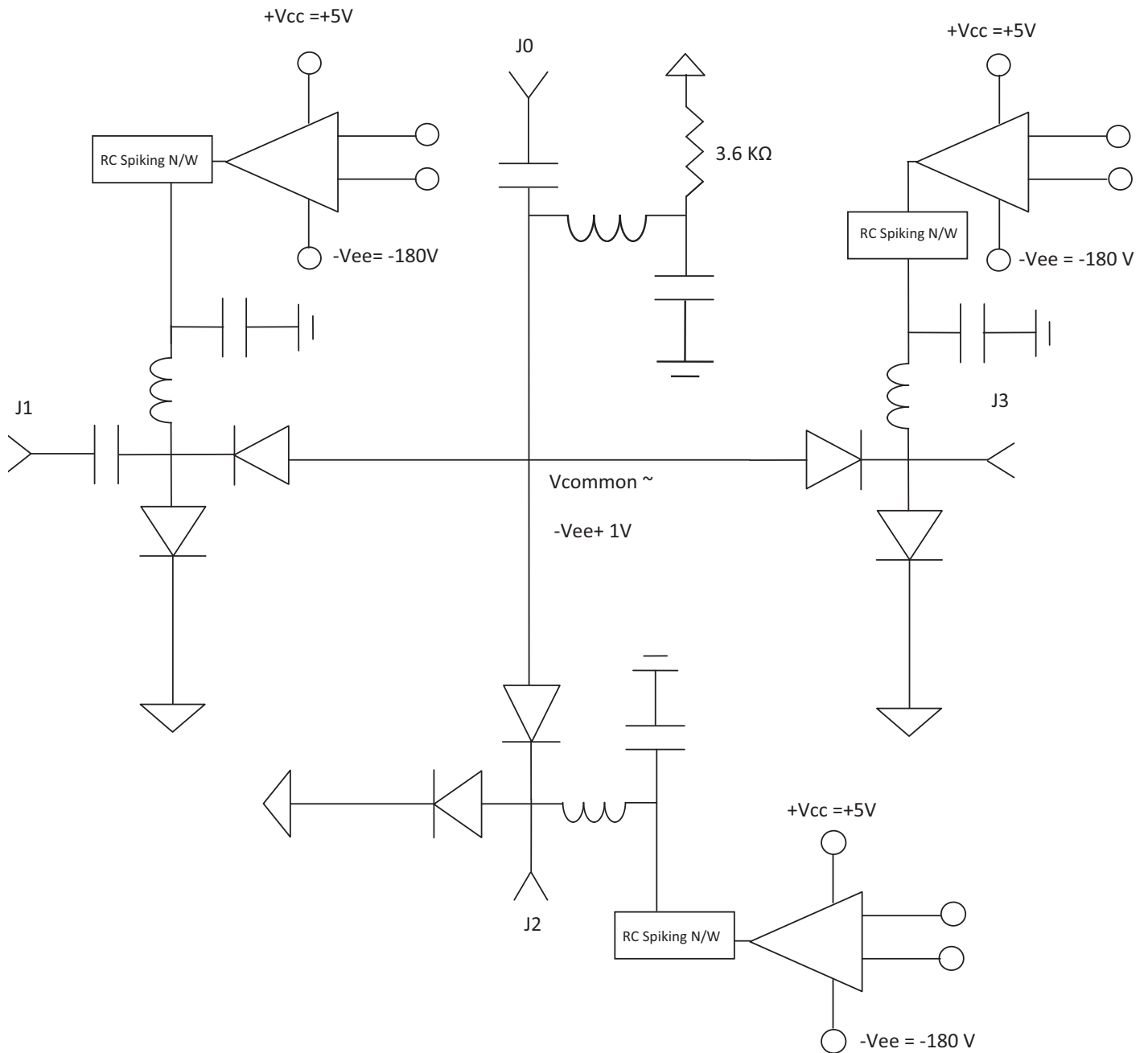

PIN Diode Driver



Notes for MPD3T5N200-703 with Series-Shunt SP3T:

1. Low Output Voltage Current, I_{shunt} , (from $+V_{CC} = +5\text{ V}$) to Forward Bias the ON SHUNT PIN Diode (Isolation State) is determined by the bias resistor, R_{shunt} , according to Ohm's Law:

$$R_{shunt} = (+5\text{ V} - \Delta V_{diode} - V_{CESsat}) / (I_{shunt}) = (+3.6\text{ V}) / (I_{shunt})$$
 I_{shunt} range = +5 to +50 mA.
2. High Output Voltage Current, $-I_{series}$, (from $-V_{EE}$) to Forward Bias the ON SERIES PIN Diode (Insertion Loss State) is determined by the bias resistor, R_{series} , according to Ohm's Law:

$$R_{series} = (-V_{EE} + 2\Delta V_{diode} + V_{CESsat}) / (I_{series}) = (-V_{EE} + 2.3\text{ V}) / (I_{series})$$
 $-I_{series}$ range = -5 to -50 mA.
 As Example, using $-V_{EE} = -200\text{ V}$ and requiring $-I_{series} =$ for -50 mA, $R_{series} = -197.7\text{ V} / 0.05\text{ A} = 3.95\text{ K}\Omega$.
 Power Dissipation = $I^2R = (5E-2)^2 (3.95\text{ E}+3) = 9.9\text{ W}$.
3. Switching Speed (50 % TTL – 10/90 % RF Voltage) is a Function of the PIN Diode Driver Performance. A RC "Current Spiking Network" is used on the Driver outputs (V1a & V1b) to provide a $I_c = C\text{ dV/dt}$ transient current to move Stored charge through the PIN Diode, typical values are:
 $R_{shunt} = 68 - 680\ \Omega$ and $C1 = 470 - 1,000\text{ pF}$.
4. For Hot Switching Applications, PIN Diode Driver must Transition from Forward Bias to Reverse Bias and Reverse Bias to Forward Bias within 500 ns (10 % - 90 % Output Voltage) with a parallel RC spiking network at the Driver Output (V1a & V1b) per Note 3.

MPD3T5N200-703 PIN Diode Driver and MSW3200-320 Symmetrical SP3T
 Truth Table using $+V_{CC} = +5\text{ V @ } +20\text{ mA}$ and $-V_{EE} = -50\text{ V @ } -50\text{ mA}$

RF State	J1 Bias	J2 Bias	J3 Bias	TTL Logic
J1-J0 Low Loss & J2-J0 Isolation & J3-J0 Isolation	-180 V @ -50 mA	+1 V @ +25 mA	+1 V @ +25 mA	CTL1 = 1 CTL2 = 0 CTL3 = 0
J2-J0 Low Loss & J1-J0 Isolation & J3-J0 Isolation	+1 V @ +25 mA	-180 V @ -50 mA	+1 V @ +25 mA	CTL1 = 0 CTL2 = 1 CTL3 = 0
J3-J0 Low Loss & J1-J0 Isolation & J2-J0 Isolation	+1 V @ +25 mA	+1 V @ +25 mA	-180 V @ -50 mA	CTL1 = 0 CTL2 = 0 CTL3 = 1

MPD3T5N200-703 PIN Diode Driver Input Output (I/O) Table

I/O Port	Description
J1 (PIN 1)	+V _{CC} & -V _{EE} RTN
J2 (PIN 2)	+V _{CC} & -V _{EE} RTN
J3 (PIN 3)	+V _{CC} & -V _{EE} RTN
J4 (PIN 4)	V1a (Voltage/Current Output #1a)
J5 (PIN 5)	V1a (Voltage/Current Output #1b)
J6 (PIN 6)	V2a (Voltage/Current Output #2a)
J7 (PIN 7)	V2b (Voltage/Current Output #2b)
J8 (PIN 8)	V3a (Voltage/Current Output #3a)
J9 (PIN 9)	V3b (Voltage/Current Output #3b)
J10 (PIN 10)	-V _{EE}
J11 (PIN 11)	+V _{CC} & -V _{EE} RTN
J12 (PIN 12)	+V _{CC} & -V _{EE} RTN
J13 (PIN 13)	+V _{CC}
J14 (PIN 14)	TTL Input Control (CTL3)
J15 (PIN 15)	TTL Input Control (CTL2)
J16 (PIN 16)	TTL Input Control (CTL1)

Absolute Maximum Ratings @ T_A = +25 °C (Unless Otherwise Defined)

Parameter	Absolute Maximum Value
INPUT Voltage 1 (+V _{CC})	-0.1 V to + 5.5 V
INPUT Voltage 1 (-V _{EE})	+0.1 V to -210 V
TTL INPUT Voltage (CTL1)	-0.5 V to + 5.5 V
+V _{CC} Source Current	+60 mA
-V _{EE} Source Current	-60 mA
Operating Temperature	-65 °C to +125 °C
Storage Temperature	-65 °C to +150 °C
Junction Temperature	+175 °C
Assembly Temperature	+260 °C for 10 Seconds
Total Dissipated D.C. Power	6.0 W @ +85 °C Case Temperature

PIN Diode Driver

Assembly Instructions

The MPD3T5N200-703 PIN Diode Drivers are capable of being placed onto circuit boards with pick and place manufacturing equipment from tube or tape-reel dispensing. The devices are attached to the circuit board using conventional solder re-flow or wave soldering procedures with RoHS type or Sn 63 / Pb 37 type solders per Table I and Graph I Time-Temperature recommended profile.

Table 1: Time-Temperature Profile for Sn 60/Pb40 or RoHS Type Solders

Profile Feature	Sn-Pb Eutectic Assembly	Pb-Free Assembly
Average ramp-up rate (T_L to T_P)	3°C/second maximum	3°C/second maximum
Preheat - Temperature Minimum (T_{SMIN}) - Temperature Maximum (T_{SMAX}) - Time (Minimum to maximum) (t_s)	100°C 150°C 60-120 seconds	150°C 200°C 60-180 seconds
T_{SMAX} to T_L - Ramp-up Rate		3°C/second maximum
Time Maintained above: - Temperature (T_L) - Time (t_L)	183°C 60-150 seconds	217°C 60-150 seconds
Peak Temperature (T_P)	225 +0 / -5°C	245 +0/-5°C
Time within 5°C of actual Peak Temperature (T_P)	10-30 seconds	20-40 seconds
Ramp-down Rate	6°C/second maximum	6°C/second maximum
Time 25°C to Peak Temperature	6 minutes maximum	8 minutes maximum

Graph1: Solder Re-Flow Time-Temperature Function

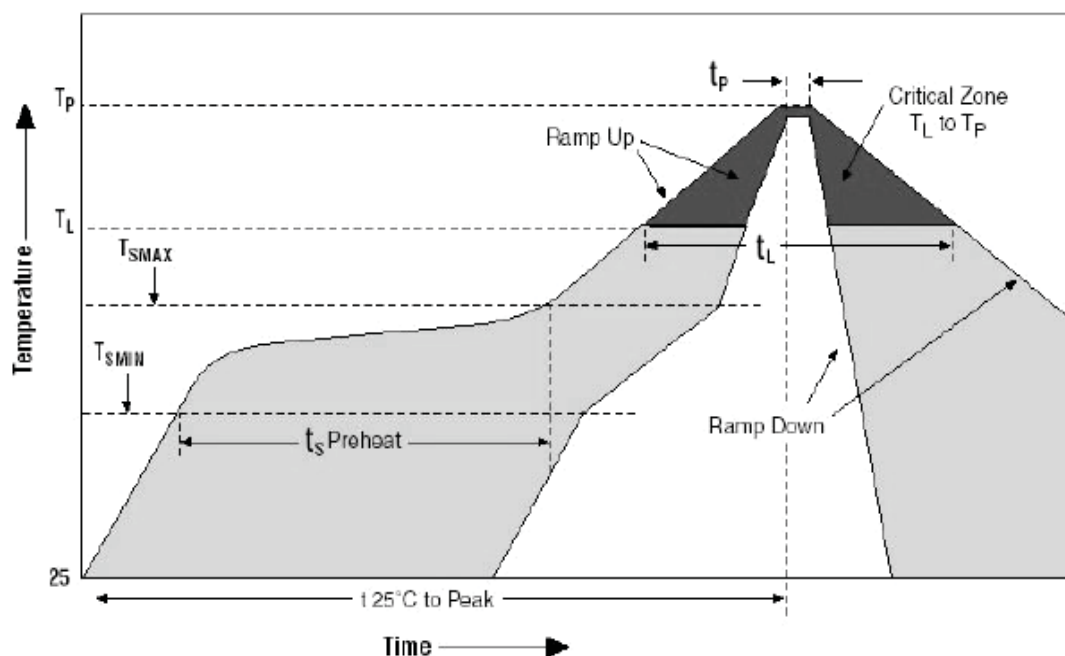

MPD3T5N200-703 Outline Drawing Case Style 703 (CS703)

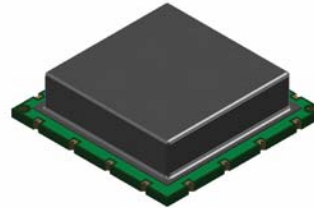
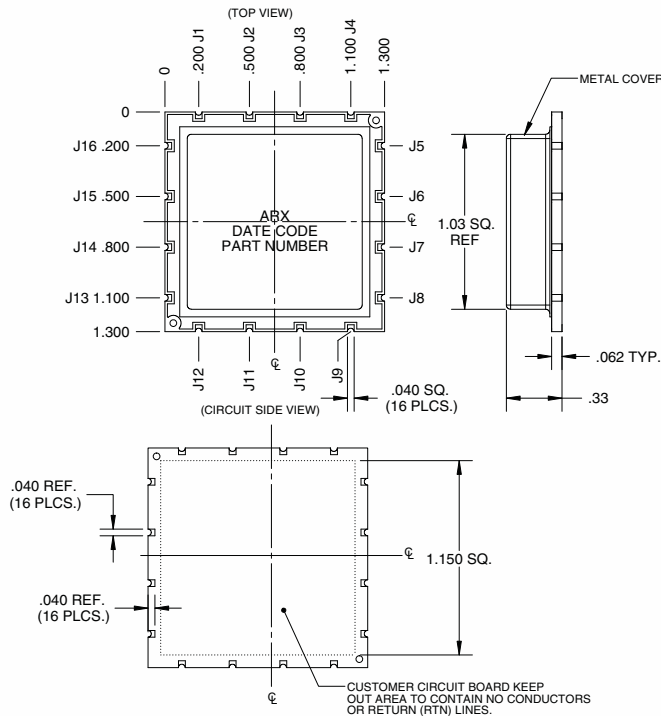

Notes:

1. CIRCUIT BOARD MATERIAL IS FR-4 TYPE.
2. METALLIZATION: 2oz Cu FOLLOWED BY, 150µin TYP. Ni, FOLLOWED BY 4µin TYP. Au.

Backside Area of PIN Diode Driver has a Keep out Area that should not contain any Conductors or Return (Ground) Lines.

Part Number Ordering Information:

Part Number	Packaging
MPD3T5N200-703-R	Tape-Reel Packaging (Quantities of 250 or 500)
MPD3T5N200-703-W	Waffle Packaging
MPD3T5N200-703-E	Evaluation Board

Aeroflex / Metelics, Inc.

54 Grenier Field Road, Londonderry, NH 03053
 Tel: (603) 641-3800
 Sales: (888) 641-SEMI (7364)
 Fax: (603)-641-3500
 975 Stewart Drive, Sunnyvale, CA 94085
 Tel: (408) 737-8181
 Fax: (408) 733-7645

www.aeroflex.com/metelics metelics-sales@aeroflex.com

Aeroflex / Metelics, Inc. reserves the right to make changes to any products and services herein at any time without notice. Consult Aeroflex or an authorized sales representative to verify that the information in this data sheet is current before using this product. Aeroflex does not assume any responsibility or liability arising out of the application or use of any product or service described herein, except as expressly agreed to in writing by Aeroflex; nor does the purchase, lease, or use of a product or service from Aeroflex convey a license under any patent rights, copyrights, trademark rights, or any other of the intellectual rights of Aeroflex or of third parties.

Copyright 2009 Aeroflex / Metelics. All rights reserved.

ISO 9001:2008 certified companies



Our passion for performance is defined by three attributes represented by these three icons: solution-minded, performance-driven and customer-focused.